

浙江恒齿传动股份有限公司  
ZHEJIANG EVERGEAR DRIVE CO.,LTD.

No. 199, Wanshun Road, Wanquan Town,  
Pingyang County, Wenzhou City, Zhejiang Province

浙江省温州市平阳县万全镇万顺路199号  
电话(TEL): 0577-63706661 63706662 63706663  
传真(FAX): 0577-63186666 63706669  
E-mail: zhejiang@evergear.com.cn

www.evergear.com.cn

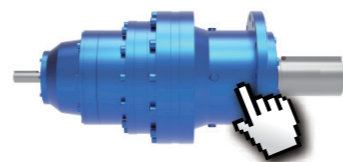

**EQ300 SERIES**  
INDUSTRIAL PLANETARY GEARBOX  
工业行星减速机

www.evergear.com.cn



浙江恒齿传动股份有限公司是一家集减速机产品研发、生产制造、销售服务于一体的知名企业。

公司主导系列产品有：ER、EK、EF、ES、EH/EB、EQ、EZ等12种之多，配套功率0.18-4000KW，数万种传动比，并通过 ISO9001 质量管理体系、ISO14001 环境管理体系、ISO45001 职业健康安全管理体系和欧盟 CE 认证，以高品质著称的“恒齿”产品供广大客户选择。

公司坚持以科技创新为本，具有“省级企业研究院”称号，致力于国际、国内减速机设备的研制、开发和数字化设计，目前已取得 10 多项发明专利，70 多项实用新型专利。

公司作为中国减速机标准化委员会委员单位已组织制定多项行业标准，获评“国家高新技术企业”“品字标浙江制造”“浙江省科技型企业”“浙江省专利示范企业”“中国行业减速机十大品牌”“浙江省企业成长之星”“省级 AAA 级重合同守信用企业”、“省专精特新中小企业”“省级知识产权示范企业”“浙江制造精品名单”“生产制造方式转型示范项目名单”等多项荣誉称号。

我们秉承“恒之以心，齿之以恒”的理念，热忱欢迎国内外新老朋友，莅临恒齿公司参观指导。

Zhejiang EVERGEAR Drive Co.,Ltd is a national high-tech enterprise that integrates the research and development, production, manufacturing, sales and service of gear reducer products.

Company Leading products: ER, EK, EF, ES, EH/EB, EQ, EZ, etc twelve series. Motor power range: 0.18 - 4000KW, nearly tens thousands of ratios. The company has passed ISO9001 quality management system, ISO14001 environmental management system, ISO45001 occupational health and safety management system, and CE certification. Serial "EVERGEAR" products are for your choice.

The company adheres to technological innovation and has the title of "Provincial Enterprise Research Institute". It is committed to the research, development, and digital design of international and domestic reducer equipment. At present, it has obtained 10 invention patents and 70 utility model patents.

As a member unit of the China Reducer Standardization Committee, it has established many industry standards, the company has been awarded the titles of "National High-tech Enterprise", Label certification of Zhejiang Made- "品" (product), "Zhejiang Science and Technology Enterprise", "Zhejiang Patent Demonstration Enterprise", "Top Ten Chinese Reducer Brands", "Zhejiang Province Growing Star Enterprise", "Provincial AAA Level Contract Abiding and Trustworthy Enterprise", "Provincial specialized, Refined, and New small and Medium Enterprise", "Provincial Intellectual Property Demonstration Enterprise", "List of quality products made in Zhejiang" "List of demonstration projects for transformation of production and manufacturing methods" etc honorary titles.

We adhere to the concept of "Persist in heart, Persistent gears", we warmly welcome new and old friends from domestic and abroad to visit EVERGEAR for guidance.

## 先进的生产设备 是确保产品质量最好的物质基础

环保-污水处理 / 化工搅拌 / 新能源汽车 / 钢铁冶金 / 筑路机械 / 包装机械 / 塑料机械  
物流自动线 / 光伏行业 / 电力水泥设备 / 动车轮毂设备 / 纺织设备 / 港口起重设备 / 金属拉丝设备  
盾构机 / 啤酒饮料设备 / 粮食机械设备 / 电子专用设备 / 煤炭输送...

environmental protection sewage treatment / chemical mixing / new energy vehicles / steel metallurgy  
road construction machinery / packaging machinery / plastic machinery / automatic logistics lines / photovoltaic industry  
power cement equipment / wheel hub equipment / textile equipment / port lifting equipment  
metal drawing equipment / Shield boring machine / Beer and beverage equipment  
Grain machinery and equipment / Electronic special equipment / Coal transportation

**COMPANY BRAND:**  
公司品牌:  
EVERGEAR 恒齿传动 恒齿减速机 恒齿机械 恒齿 恒齿工 EVERGEAR



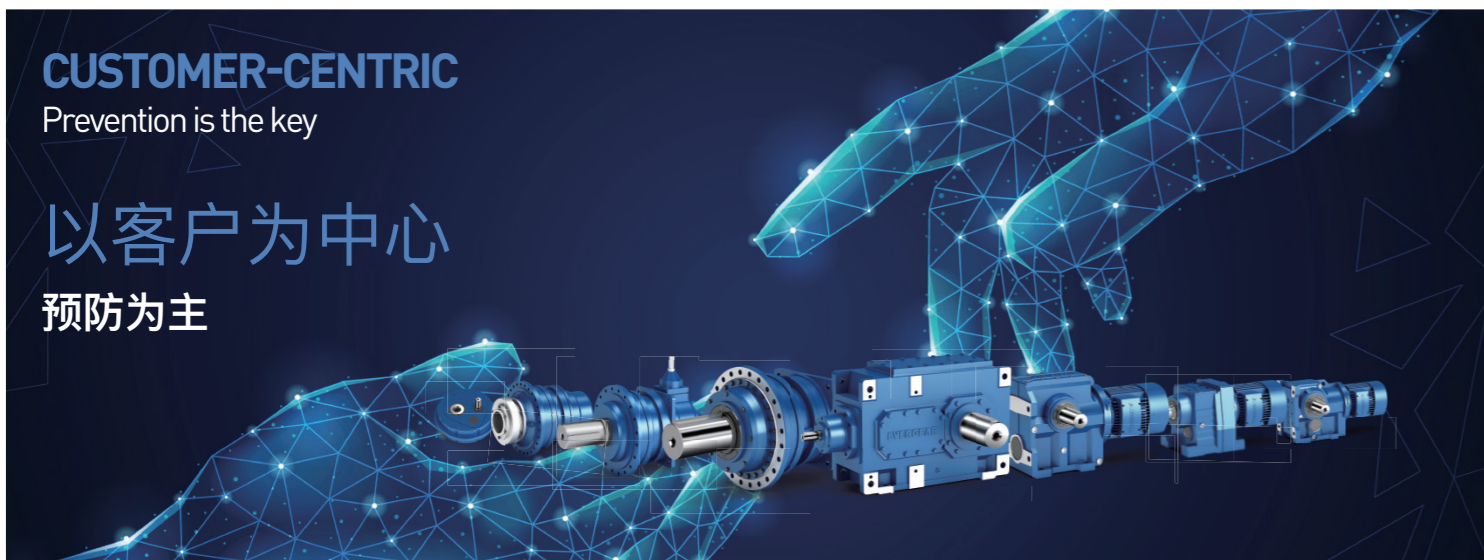
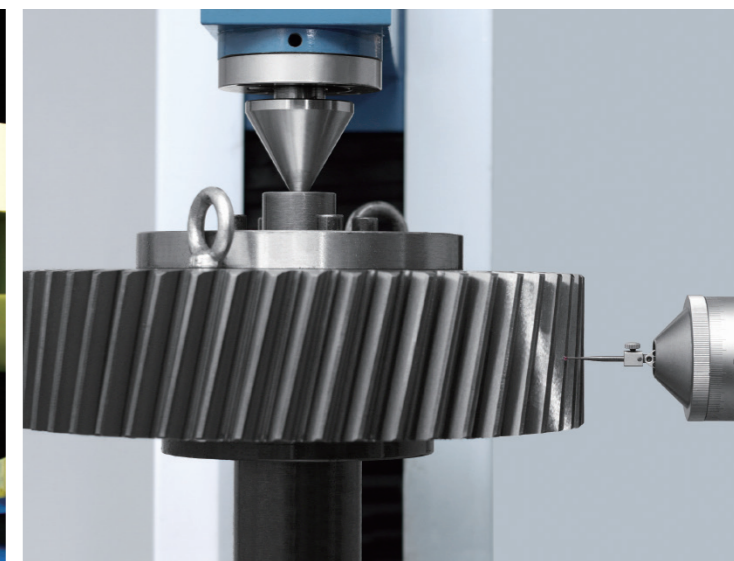
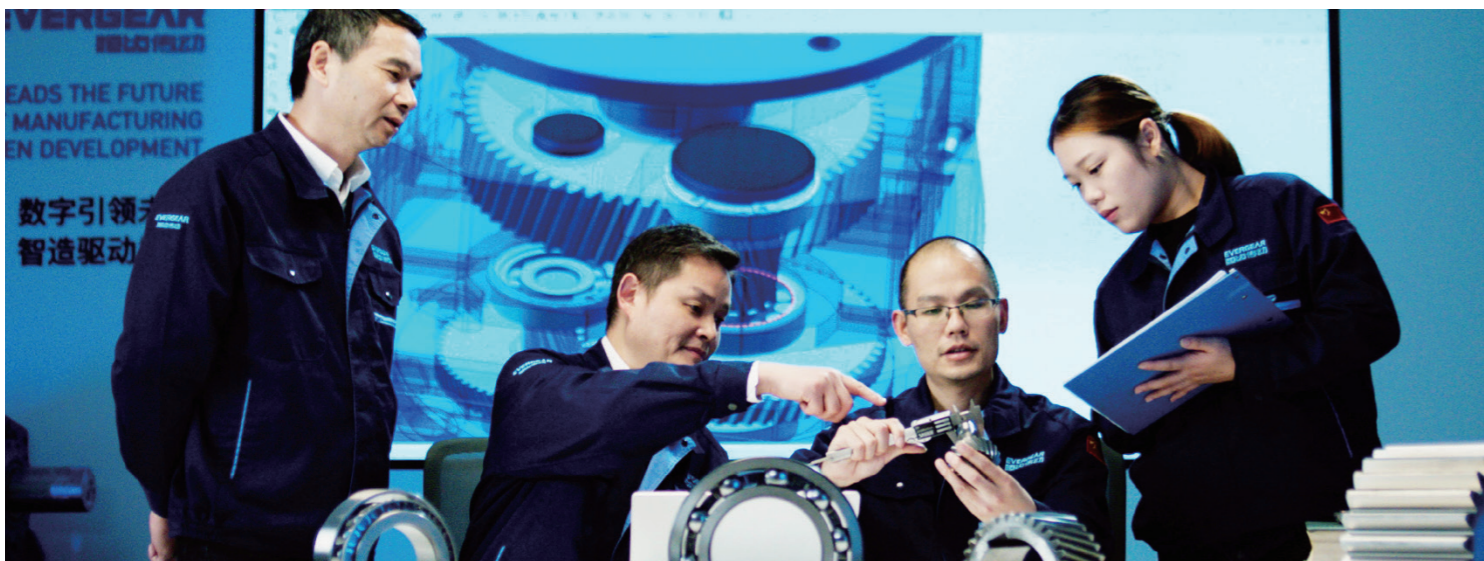

## CUSTOMER-CENTRIC

Prevention is the key

# 以客户为中心

## 预防为主



Advanced Production Equipments  
Are the best material foundation for  
Quality Assurance.

先进的生产设备  
是确保产品质量最好的物质基础

## PRODUCT DESIGN DEVELOPMENT

### 设计&研发

产品源于人品，恒齿传动除了拥有一流的生产设备外，让人更为叹服的是恒齿传动研发中心那些在业内颇负盛名的人才及公司从未放松过的对一线生产工人的管理与培训。保证了公司持续的高效运转，产品质量长期稳定。

作为一个集研发、生产于一身的企业，恒齿传动公司致力于国际、国内减速机设备的研制、开发和数字化设计为国内外各个行业的机械传动提供专业的设计方案。

恒齿传动在硬件设施方面有足够骄傲的资本，从整体误差测量仪，跳动检测仪、齿轮蜗轮双面检查仪到代表国际顶级水平的高效、高精度的磨齿机及各类数控机床，都给予产品质量最好的物质基础。

Product is rooted in personality. EVERGEAR is in addition to the first class production equipments, what is even more impressive is the talents of research and development center management and training for first-line production workers. That has ensured the company with high efficient operation and made long term stability of product's quality.

As a research development and production enterprise , EVERGEAR company devotes to international and domestic reducer equipments research, development and digital design solutions for mechanical transmission in all kinds of industries.

EVERGEAR has enough hardware equipments, from the gear integrated error test instruments, gear runout detector , gear and worm gear double contact test instruments to the world advanced level, with high efficiency and high precision grinding tooth machine and all kinds of CNC machine tools , etc. to provide the material foundation of good quality.



## EQ

SPIRAL BEVEL  
GEAR REDUCER  
行星齿轮减速机

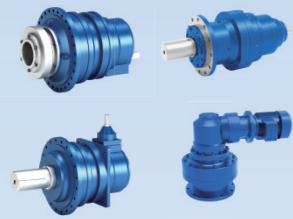

## EH EB

HIGH POWER  
REDUCER  
大功率齿轮减速机



## ER

HELICAL  
GEAR MOTOR  
斜齿轮硬齿面减速机



## EF

PARALLEL SHAFT  
HELICAL GEAR MOTOR  
平行轴斜齿轮减速机



## EK

HELICAL-BEVEL  
GEAR MOTOR  
弧齿锥齿轮硬齿面减速机

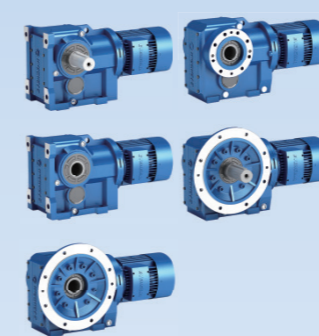

## ES

HELICAL-WORM  
GEAR MOTOR  
蜗轮蜗杆减速机



## EZ

SPIRAL BEVEL  
GEAR MOTOR  
弧齿锥齿轮减速机



## ZGY

SHAFT-MOUNTED  
REDUCER  
悬挂式减速机

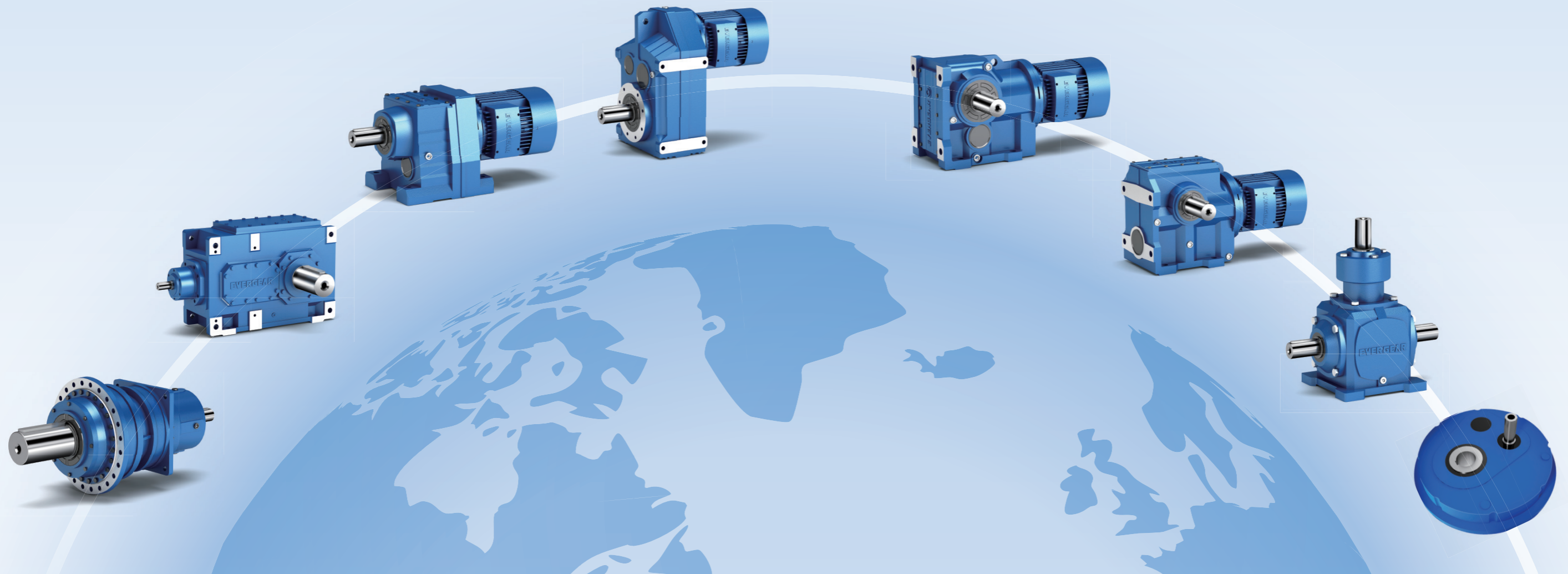



# WHEREVER YOU ARE WE ARE...





## 1 规格 Specifications

EQ300系列包含了一组多功能行星齿轮箱。其主要特点:

The EQ300 series comprises a set of multifunctional planetary gearboxes. Its main features include:

- 16 种机座号, 模块化设计
  - 型式:
    - 同轴式包括1至4级减速型式
    - 直角轴式包括2至4级减速型式 (第一级为螺旋伞齿轮)
  - 法兰、地脚和轴装方式
  - 带平键输出轴, 花键输出轴, 花键空心轴, 带收缩盘空心输出轴
  - 输入连接方式
    - IEC 标准电机
    - 轴输入
    - 伺服电机
  - 平键输入轴
  - 齿轮减速电机
  - 安装的附件:
    - 法兰
    - 小齿轮
    - 花键轴
    - 收缩盘
  - 结构方式
- 16 types of frame sizes, modular design
  - Type:
    - The coaxial type includes 1 to 4 stages of reduction gearing
    - The right-angle shaft type includes 2 to 4 stages of reduction gear types (with the first stage being a spiral bevel gear)
  - Flange, foundation, and shaft mounting methods
  - Output shaft with flat key, output shaft with spline,
  - hollow shaft with spline, hollow output shaft with shrink disc
  - Input connection method
    - IEC standard motor
    - Axis input
    - servo motor
  - Flat key input axis
  - Gear reduction motor
  - Installed accessories:
    - Flange
    - Pinion
    - Spline shaft
    - Shrinking disk
  - Structural method

结构形式 structural style	功率 power	转矩 torque	减速比 ratio	效率 efficiency	噪音 noise
 同轴式 COAXIAL	$0.25 \leq P_n [\text{kW}] \leq 20$	$M_n \leq 520000 \text{ Nm}$	$3.4 \leq i \leq 290$	高 HIGH	中 MIDDLE
 直角轴式 RIGHT ANGLE SHAFT TYPE	$0.25 \leq P_n [\text{kW}] \leq 7$	$M_n \leq 400000 \text{ Nm}$	$7 \leq i \leq 95$	高 HIGH	中 MIDDLE

- 更多特点:
  - 可选转矩种类繁多;
  - H和P型中使用了重型圆锥滚子轴承, 能承受很高的悬臂载荷与径向载荷;
  - 高效率;
  - 零件间使用花键连接, 比使用平键连接更好;
  - 行星轮安装在自动定心装置上, 确保每个齿轮承受相同负载;
  - 球墨铸铁箱体。
- More features:
  - There is a wide variety of optional torques;
  - Heavy-duty tapered roller bearings are used in H and P types, which can withstand high cantilever loads and radial loads;
  - High efficiency;
  - Using a spline connection between parts is better than using a flat key connection;
  - The planetary gears are installed on an automatic centering device to ensure that each gear bears the same load;
  - Ductile iron box body.

## 2 符号及计量单位 Symbols and units of measurement

符号 Symbol	单位 Unit	说明 Describe
$A_{c2}$	[N]	输出轴计算用轴向力 Axial force for output shaft calculation
$A_{r2}$	[N]	输出轴的轴向力 Axial force of output shaft
$A_{n2}$	[N]	输出轴所允许的轴向力 Allowable axial force of output shaft
$f_{a2}$	-	轴向负载系数 Axial load coefficient
$f_L$	-	寿命系数 Life factor
$f_m$	-	调节系数 adjustment coefficient
$f_{v1} f_{v2}$	-	输入和输出轴上的速度系数 Velocity coefficients on input and output axes
$f_u$	-	使用系数 use coefficient
$f_t$	-	热功率系数 Thermal power coefficient
$f_v$	-	计算热功率的速度系数 Calculate the velocity coefficient of thermal power
$f_{r1} A_{x2}$	-	输入和输出轴上的径向载荷位置系数 Radial load position coefficients on input and output shafts
$h$	[h]	寿命小时数 Lifespan hours
$i$	-	传动比, 速比 Gear ratio
$K_a$	-	轴向载荷系数 axial load factor
$K_r$	-	径向载荷系数 radial load factor
$l$	-	循环周期系数 Cyclic period coefficient
$M_b$	[Nm]	额定制动转矩 Rated braking torque
$M_{c2}$	[Nm]	计算用输出转矩 Calculate the output torque for use
$M_2$	[Nm]	传递到输出轴的转矩 Torque transmitted to the output shaft
$M_{n2}$	[Nm]	额定输出转矩 Rated output torque
$M_{2max}$	[Nm]	最大输出转矩 Maximum output torque
$M_{r1}$	[Nm]	输入轴所需转矩 Required torque for input shaft
$M_{r2}$	[Nm]	输出轴所需转矩 Required torque for output shaft
$n_1$	[min <sup>-1</sup> ]	输入转速 input speed
$n_2$	[min <sup>-1</sup> ]	输出转速 output speed
$P_1$	[kW]	最大输入功率 Maximum Input Power
$P_2$	[kW]	输出功率 output power
$P_n$	[kW]	电机额定功率 Motor rated power
$P_r$	[kW]	所需的输入功率 Required input power
$P_{r2}$	[kW]	最大输出转速时的输出功率 Output power at maximum output speed
$P_s$	[kW]	损耗功率 Loss power
$P_t$	[kW]	齿轮箱热功率 Gearbox thermal power
$R_{r1}$	[N]	输入轴计算用径向力 Radial force for input shaft calculation
$R_{r2}$	[N]	输出轴计算用径向力 Radial force for output shaft calculation
$R_{r1} R_{r2}$	[N]	输入和输出轴中点的额定径向载荷 Rated radial load at the midpoint of the input and output shafts
$R_{c2}$	[N]	在轴中间点的容许悬臂载荷 Allowable cantilever load at the midpoint of the axis
$S$	-	安全系数 safety factor
$t_a$	[°C]	环境温度 ambient temperature
$x$	[mm]	悬臂载荷的作用距离 The operating distance of cantilever load
$\eta_d$	-	动态效率 Dynamic efficiency
$Z$	-	每小时启动次数 Number of starts per hour



这个符号表示重量  
This symbol represents weight

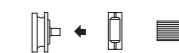

这些符号表示安装所需的辅助装置  
These symbols represent the auxiliary devices required for installation



黑色区域表示输入部件  
The black area represents the input component



扳手下面的数字表示额定拧紧力矩  
The number below the wrench represents the rated tightening torque



同轴式减速机  
Coaxial reducer



直角轴式减速机  
Right angle shaft reducer



蜗轮行星组合  
Worm gear planetary combination



斜齿轮锥齿轮行星组合  
Helical gear, bevel gear, planetary combination



3 结构形式  
Structural style

- A** 1 一体化电机  
Integrated motor
- 2 IEC电机  
IEC motor
- 3 电机接头  
Motor connector
- 4 轴输入  
Axis input
- 5 带风扇实心轴输入  
Solid shaft input with fan
  
- B** 6 直角减速级  
Right angle deceleration stage
- 7 单级行星减速  
Single-stage planetary deceleration
- 8 两级或以上行星减速  
Two or more planetary decelerations
- 9 蜗轮减速机与行星减速机组合  
Combination of worm gear reducer and planetary reducer
- 10 斜齿轮-锥齿轮减速机与行星减速机组合  
Combination of helical bevel gear reducer and planetary reducer
  
- C** 11 MC/MZ-带平键或花键实心轴输出  
Solid shaft output with flat keys or splines
- 12 HC/HZ-带平键或花键加强型实心轴输出  
Solid shaft output with flat or spline reinforcement
- 13 PC/PZ-底座支撑带平键或花键实心轴输出  
Base support with flat key or spline solid shaft output
- 14 FZ-带花键空心轴输出  
Hollow shaft output with spline
- 15 FP-配收缩盘空心轴输出  
equipped with shrink disc hollow shaft output
- 16 HC-平键实心轴输出  
Flat key solid axis output
- 17 HZ-带花键实心轴输出  
Solid shaft output with spline
- 18 FZ-带花键空心轴输出  
Hollow shaft output with spline
- 19 FP-配收缩盘空心轴输出  
equipped with shrink disc hollow shaft output
- 20 PC-地脚安装  
foundation installation
- 21 VK-搅拌机用加强型平行实心轴输出  
mixer with reinforced parallel solid shaft output
  
- D** 22 WOA-法兰  
WOA flange
- 23 P\_- 齿轮  
P\_- Gear
- 24 MOA -连接套管  
MOA - Connecting sleeve
- 26 端盖  
end cap
- 26 BOA-花键轴  
BOA spline shaft
- 27 GOA-收缩盘  
GOA Shrink Disk

输入结构  
Input structure

**A**

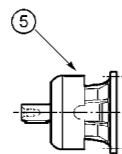
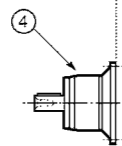
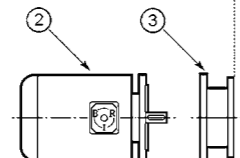
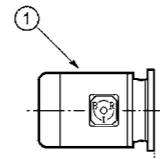

减速结构  
Deceleration structure

**B**

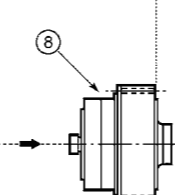
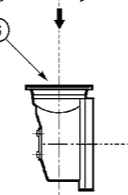
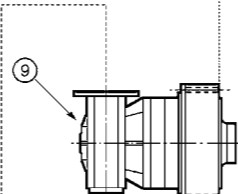
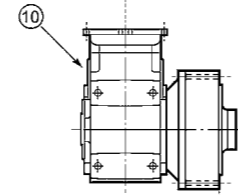

输出结构  
Output

**C**

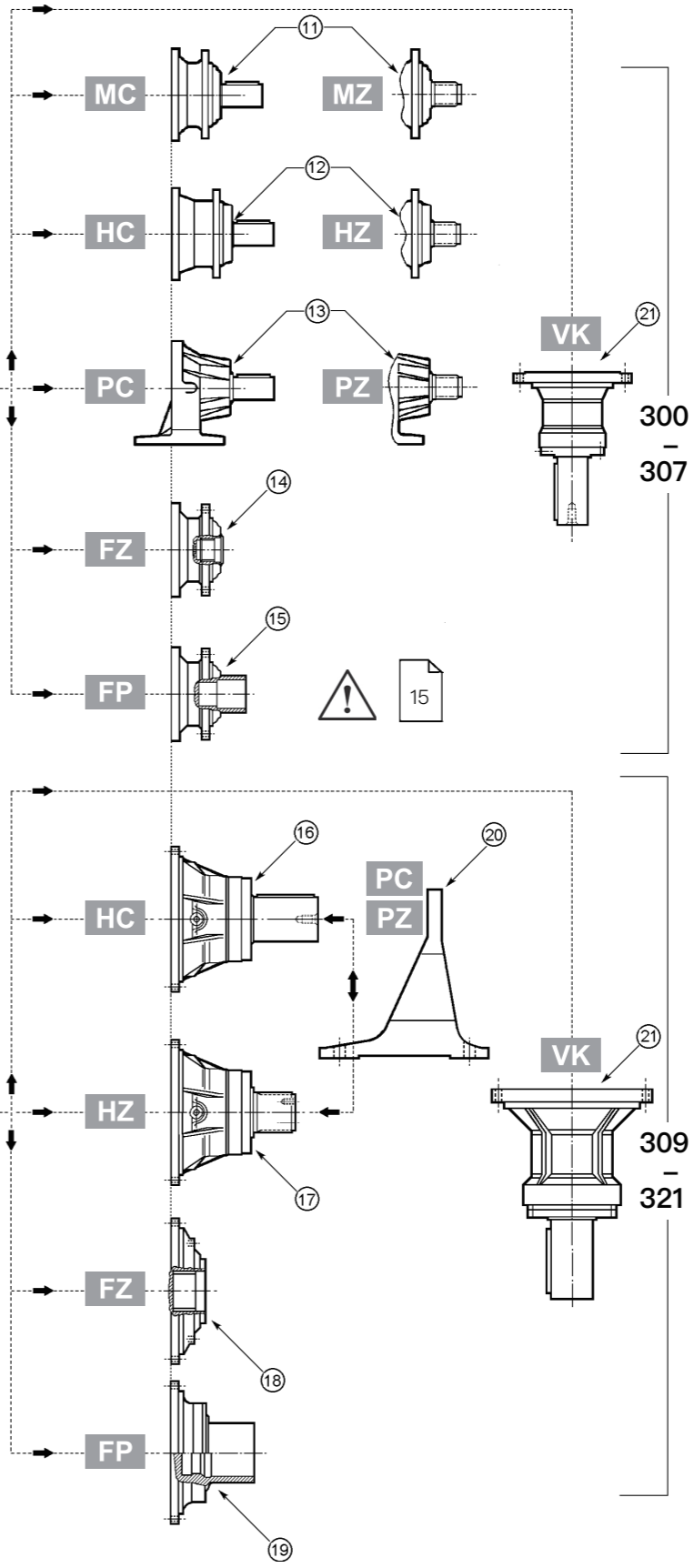

配合结构  
Coordination structure

**D**

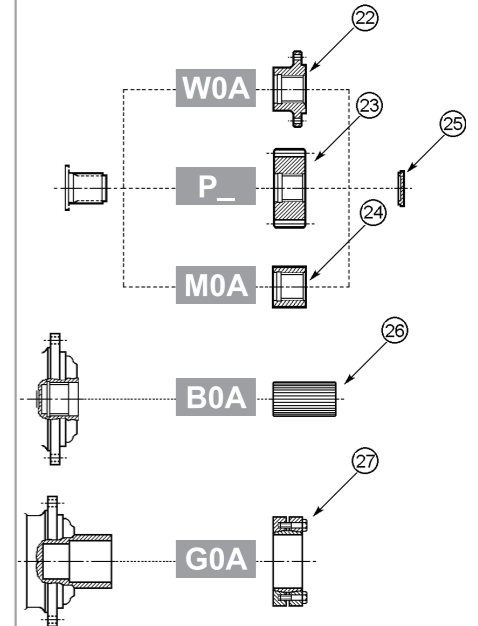



## 4 输出转矩 Output Torque

减速电机传递的转矩  $M_2$  [Nm]

The torque transmitted by the deceleration motor  $M_2$  [Nm]

- 指在理论寿命为10000小时, 装机功率  $P_n$ , 安全系数  $S$  的条件下齿轮箱传递的有效输出转矩, 转矩值已经考虑到齿轮箱的效率。
- The effective output torque transmitted by the gearbox under the conditions of a theoretical lifespan of 10000 hours, installed power  $P_n$ , and safety factor  $S$ , taking into account the efficiency of the gearbox.

额定输出转矩  $M_{n2}$  [Nm]

Rated output torque  $M_{n2}$  [Nm]

- 指齿轮箱的能安全传递的转矩, 条件为
  - 负载均匀, 安全系数  $S=1$
  - 理论寿命为10000小时
- The torque that can be safely transmitted by the gearbox, provided that
  - Uniform load, safety factor  $S=1$
  - Theoretical lifespan is 10000 hours
- $M_{n2}$  值遵守以下标准:
  - ISO DP 6336 齿轮标准
  - ISO 281 轴承标准
- The  $M_{n2}$  value follows the following standards:
  - ISO DP 6336 Gear Standard
  - ISO 281 Bearing Standard

最大转矩  $M_{2max}$  [Nm]

Maximum torque  $M_{2max}$  [Nm]

- 指齿轮箱在静态条件或高起停运转条件下所能承受的输出转矩。通常是指峰值负载或启动负载。
- Refers to the output torque that the gearbox can withstand under static conditions or high start stop operation conditions. Usually refers to peak load or start-up load.

实际所需转矩  $M_{r2}$  [Nm]

Actual required torque  $M_{r2}$  [Nm]

- 所需转矩取决于应用场合的实际工况。拟选齿轮箱的额定转矩  $M_{n2}$  必须大于这个转矩。
- The required torque depends on the actual operating conditions of the application scenario. The rated torque  $M_{n2}$  of the proposed gearbox must be greater than this torque.

计算用转矩  $M_{c2}$  [Nm]

Calculate torque  $M_{c2}$  [Nm]

- 计算用转矩会在选择齿轮箱时被用到, 可以由实际所需转矩  $M_{r2}$  和使用系数  $f_s$ , 按以下公式得出。
- The calculation of torque will be used when selecting a gearbox, which can be obtained from the actual required torque  $M_{r2}$  and the usage factor  $f_s$  according to the following formula.

$$M_{c2} = M_{r2} \times f_s \leq M_{n2} \quad (1)$$

## 5 功率 Power

额定输入功率  $P_{n1}$  [kW]

Rated input power  $P_{n1}$  [kW]

- $P_{n1}$  是指齿轮箱安全的最大输入功率:
  - 输入转速为  $n_1$
  - 安全系数  $S=1$
  - 理论寿命为 10000 小时
- $P_{n1}$  refers to the maximum safe input power of the gearbox:
  - Input speed is  $n_1$
  - Safety factor  $S=1$
  - Theoretical lifespan is 10000 hours

输出功率  $P_2$  [kW]

Output power  $P_2$  [kW]

- 输出功率是指传递到输出轴的有效功率, 可按以下公式得出:
- Output power refers to the effective power transmitted to the output shaft, which can be calculated according to the following formula:

$$P_2 = P_1 \times \eta_d \quad (2)$$

$$P_2 = \frac{M_{r2} \times n_2}{9550} \quad (3)$$

## 6 热功率 $P_t$ [kW] Thermal power $P_t$ [kW]

- 热功率值与齿轮箱的发热限制相关。具体数值在齿轮箱额定值表中列出。该参数表示在输入转速  $n_1$ 、环境温度为  $20^\circ\text{C}$ 、不带附加冷却系统的条件下, 齿轮箱能持续传递的功率。在短工作时间和长时间停止的工况中, 如果停止时间较长, 齿轮箱的温度能冷却, 则热功率就不再有意义, 在计算时可以忽略。在工作环境不同于  $20^\circ\text{C}$ 、间歇工作制、或输入转速  $n_1$ , 不是额定值时,  $P_t$  值应由表 (A1) 中的热功率系数  $f_t$  和/或速度系数  $f_v$  进行调整。确保满足以下条件:

- The thermal power value is related to the heating limit of the gearbox. The specific values are listed in the gearbox rating table. This parameter represents the power that the gearbox can continuously transmit under the conditions of input speed  $n_1$ , ambient temperature of  $20^\circ\text{C}$ , and no additional cooling system. In the working conditions of short working time and long stopping time, if the stopping time is long and the temperature of the gearbox can cool down, the thermal power is no longer meaningful and can be ignored in the calculation. When the working environment is different from  $20^\circ\text{C}$ , intermittent working mode, or input speed  $n_1$ , which is not the rated value, the  $P_t$  value should be adjusted based on the thermal power coefficient  $f_t$  and/or velocity coefficient  $f_v$  in Table (A1). Ensure that the following conditions are met:

$$P_{r1} \leq P_t \times f_t \quad (4)$$

$t_a$ [°C]	连续工作制 continuous duty	$f_t$			
		间隙工作制 Flexible working hours system			
		负载持续率 Load duration rate			
		80%	60%	40%	20%
10	1.2	1.3	1.6	1.8	2.0
20	1.0	1.1	1.3	1.5	1.7
30	0.9	1.0	1.2	1.3	1.5
40	0.7	0.8	0.9	1.0	1.2
50	0.5	0.6	0.7	0.8	0.9

$n_1$	$f_v$
750	1.5
950	1.2
1500	1
2000	0.7

(A1)

- 循环持续时间系数是指处于工作负荷下的工作时间  $t_f$  与周期时间 ( $t_f + t_s$ ,  $t_s$  代表停止时间) 的比, 并以百分数表示。
- The cycle duration factor refers to the ratio of the working time  $t_f$  under workload to the cycle time ( $t_f + t_s$ , where  $t_s$  represents the stop time), expressed as a percentage.

$$I = \frac{t_f}{t_f + t_s} \times 100 \quad (5)$$



## 7 效率 Efficiency

### 动态效率[η] Dynamic efficiency [η]

#### 动态效率可以由以下公式计算得出: The dynamic efficiency can be calculated using the following formula:

- 动态效率可以由以下公式计算得出:
- The dynamic efficiency can be calculated using the following formula:

$$\eta_d = \frac{P_2}{P_1} \quad (6)$$

- 具体效率值如下表所示。
- The specific efficiency values are shown in the table below.

(A2)

减速级数 Deceleration level	结构形式 Structural style		
	行星结构 Planetary structure	蜗轮齿轮箱组合 Worm gear gearbox combination	直角式齿轮箱组合 Right angle gearbox combination
1	0.97	—	—
2	0.94	0.73	—
3	0.91	0.70	0.91
4	0.88	—	—

## 8 传动比 [i] Transmission ratio [i]

- 传动比等于输入转速与输出转速的比值:
- The transmission ratio is equal to the ratio of input speed to output speed:

$$i = \frac{n_1}{n_2} \quad (7)$$

## 9 工作转速 Speed:

### 输入转速 $n_1$ [min<sup>-1</sup>] Input speed $n_1$ [min<sup>-1</sup>]

#### 输入转速 $n_1$ [min<sup>-1</sup>]

齿轮箱的驱动速度,如齿轮箱与电机直接相连,则转速值与电机转速相同。

如果齿轮箱由外部传动装置驱动,转速值为电机转速经外部驱动装置的减速后的转速。在这种情况下,输入转速低于1400min<sup>-1</sup>。

输入转速不得超过齿轮箱额定值表中规定的值。

The driving speed of the gearbox, if the gearbox is directly connected to the motor, the speed value is the same as the motor speed. If the gearbox is driven by an external transmission device, the speed value is the motor speed reduced by the external drive device. In this case, the input speed is below 1400 min<sup>-1</sup>.

The input speed shall not exceed the value specified in the gearbox rated value table.

### 输出转速 $n_2$ [min<sup>-1</sup>] Input speed $n_2$ [min<sup>-1</sup>]

#### 输出转速 $n_2$ [min<sup>-1</sup>]

输出转速按照下列公式通过输入转速 $n_1$ 和传动比*i*计算出来的:

The output speed is calculated based on the input speed  $n_1$  and transmission ratio *i* using the following formula:

$$n_2 = \frac{n_1}{i} \quad (8)$$

## 10 使用系数 [f<sub>s</sub>] Usage coefficient [f<sub>s</sub>]

使用系数表现齿轮箱的应用特性。它考虑到减速机的负载类型和每日工作时间。可以参照表 (A3) 所列的值选取合适的使用系数。

Use coefficients to represent the application characteristics of gearboxes. It takes into account the load type and daily working time of the gearbox. You can refer to the values listed in Table (A3) to select the appropriate usage coefficient.

(A3)

使用系数 Use Coefficient «f <sub>s</sub> »		运行总时间 (h) Total running time (h)				
负载类型 load type	每小时启动次数 Number of starts per hour	≤ 5000	10000	15000	25000	50000
		每日运行时间 (h) Daily running time (h)				
Z		h < 4	4 < h < 8	8 < h < 12	12 < h < 16	16 < h < 24
均匀负载 uniform load	Z < 10	0.90	1.00	1.15	1.30	1.60
	10 < Z < 30	0.95	1.15	1.30	1.50	1.80
	30 < Z < 100	1.00	1.25	1.45	1.60	2.00
中等负载 Moderate Load	Z < 10	1.00	1.25	1.45	1.60	2.00
	10 < Z < 30	1.10	1.40	1.60	1.80	2.20
	30 < Z < 100	1.20	1.50	1.70	2.00	2.40
重负载 heavy load	Z < 10	1.20	1.50	1.70	2.00	2.40
	10 < Z < 30	1.30	1.60	1.80	2.10	2.60
	30 < Z < 100	1.40	1.75	2.00	2.30	2.80

## 11 安全系数 [S] Safety factor [S]

- 安全系数等于齿轮箱的额定功率与电机功率的比值。
- The safety factor is equal to the ratio of the rated power of the gearbox to the power of the motor.

$$S = \frac{P_{n1}}{P_1} \quad (9)$$

## 12 选型 Model selection

### • 齿轮减速电机选型

○ 需要预先考虑和确定的是:

- 根据负载类型、每小时启动次数和预期工作寿命确定使用系数 $f_s$ ;
  - 所需的输入功率;
- 表 (A2) 列出了不同齿轮箱的效率 $\eta_d$ 值。

### • Selection of gear reduction motor

○ What needs to be considered and determined in advance is:

- Determine the usage factor  $f_s$  based on load type, number of startups per hour, and expected working life
  - Required input power;
- Table (A2) lists the efficiency  $\eta_d$  values of different gearboxes.

$$P_{n1} = \frac{M_{r2} \times n_2}{9550 \times \eta_d} \quad (10)$$



- c) 得到所需功率 $P_{r1}$ 和输出转速 $n_2$ 后, 查找齿轮减速机额定值表, 选择合适的额定功率满足 $P_n$ 大于或等于 $P_{r1}$ 。  
除非另有说明, 否则在样本中指出的电机功率 $P_n$ 是指连续工作制S1时的电机功率。  
对于非连续工作制S1条件下使用的电机, 所需的负载类型需要参考CEI 2-3/IEC 34-1 标准。  
对于从S2到S8的工作制, 特别是对于机座号不超过132的电机, 能获得相对于连续工作制的情况时更大的功率。相应地必须满足下列条件:
- $$P_n \geq P_{r1} \quad (11)$$
- c) After obtaining the required power  $P_{r1}$  and output speed  $n_2$ , search for the rated value table of the gear reduction motor. Choose a suitable rated power that satisfies  $P_n$  greater than or equal to  $P_{r1}$ .  
Unless otherwise specified, the motor power  $P_n$  indicated in the sample refers to the motor power during continuous operation S1.  
For motors used under non continuous working S1 conditions, the required load type needs to refer to CEI 2-3/IEC 34-1 standards.  
For the working system from S2 to S8, especially for motors with a base size not exceeding 132, greater power can be obtained compared to the continuous working system.  
Correspondingly, the following conditions must be met:
- $$P_n = \frac{P_{r1}}{f_m} \quad (12)$$

调整系数 $f_m$ 能从表 (A5) 中查到。  
The adjustment factor  $f_m$  can be found in Table (A5).

	工作制 Working system						请与我们联系 Contact Us
	S2			S3*			
	循环周期 Cycle period			循环周期系数 I Cycle cycle coefficient I			
	10	30	60	25%	40%	60%	
$f_m$	1.35	1.15	1.05	1.25	1.15	1.1	

- 循环周期必须为10分钟或更短时间。否则, 请与我们的技术服务部进行联系。  
循环周期系数: 见表 (A5)。  
根据输出转速或接近的转速, 在齿轮减速机选型图表中选择合适的齿轮减速机, 使安全系数S 满足以下条件:
- $$S \geq f_s \quad (13)$$
- The cycle period must be 10 minutes or less. Otherwise, please contact our technical service department.  
Cycle cycle coefficient: see Table (A5).  
Select the appropriate gear reduction motor from the gear reduction motor selection chart based on the output speed or a similar speed, Make the safety factor S meet the following conditions:

- 减速机选型
    - 检查所选配置:
      - a) 根据负载类型、每小时启停次数和预期工作寿命确定使用系数 $f_s$ 。
      - b) 根据所需转矩 $M_{r2}$ 按以下公式得出计算用转矩:
      - c) 由所要求的输出转速 $n_2$ 和输入转速 $n_1$ 传动比:
      - d) 确定了 $M_{c2}$ 和 $i$ 后, 根据输入转速 $n_1$ 查找减速机额定值表, 选择最接近计算值的传动比并满足以下条件的齿轮箱机座号: 如果减速机要安装IEC电机接口, 必须检查接口是否适用。
- $$M_{c2} = M_{r2} \times f_s \quad (14)$$
- $$i = \frac{n_1}{n_2} \quad (15)$$

- Gearbox selection
    - Check the selected configuration:
      - a) Determine the usage factor  $f_s$  based on load type, number of starts and stops per hour, and expected working life
      - b) Calculate the required torque  $M_{r2}$  using the following formula:
      - c) Transmission ratio based on the required output speed  $n_2$  and input speed  $n_1$ :
      - d) After determining  $M_{c2}$  and  $i$ , search for the rated value table of the gearbox based on the input speed  $n_1$ , Select the gearbox base number that is closest to the calculated value and meets the following conditions: If the gearbox needs to install an IEC motor interface, it is necessary to check whether the interface is suitable.
- $$M_{n2} \geq M_{c2} \quad (16)$$

### 13 校核 Check

- 在完成选型齿轮箱与齿轮减速电机的选型之后, 必须进行下列校核工作:

- a) 热功率  
确认齿轮箱的热功率等于或大于公式 (4) 求出的所需功率。如果没有校核这一条件, 应选择较大的齿轮箱或增加强制冷却系统。
  - b) 最大转矩  
确认瞬时峰值负荷转矩和带负载启动转矩不能超过齿轮箱的额定最大转矩  $M_{2max}$  (见表 A6)
  - c) 悬臂载荷  
检查所选配置  
输入轴和输出轴上的悬臂载荷可通过下列公式求出:
- $$R_{c1-2} = \frac{2000 \times M_{r1-2} \times K_r}{d} \quad (17)$$

- After completing the selection of the gearbox and gear reduction motor, the following verification work must be carried out:

- a) Thermal power  
Confirm that the thermal power of the gearbox is equal to or greater than the required power calculated by formula (4). If this condition is not verified, a larger gearbox or an additional forced cooling system should be selected.
- b) Maximum torque  
Confirm that the instantaneous peak load torque and the starting torque with load cannot exceed the rated maximum torque  $M_{2max}$  of the gearbox (see Table A6)
- c) Cantilever load  
Check the selected configuration  
The cantilever load on the input shaft and output shaft can be calculated using the following formula:

齿轮箱 Gearbox	$M_{2max}$ [Nm]
EQ300	1200
EQ301	2400
EQ303	3500
EQ304	4800
EQ305	7000
EQ306	12000
EQ307	18000
EQ309	27000
EQ310	36000

齿轮箱 Gearbox	$M_{2max}$ [Nm]
EQ311	54000
EQ313	66000
EQ314	100000
EQ315	126000
EQ316	162000
EQ317	216000
EQ318	300000
EQ319	420000
EQ321	650000

- $R_{c1-2}$  悬臂载荷 (N)       $d$  传动部件的分度圆直径 (链轮, 齿轮, 带轮等) (mm)  
1 = 表示输入轴       $K_r = 1$  链条传动  
2 = 表示输出轴       $K_r = 1.25$  齿轮传动  
 $M_{r1-2}$  轴上的转矩 (Nm)       $K_r = 1. - 2.0$  V形带传动  
如需要延长工作寿命, 在表 (A7) 中选择寿命系数。
- $R_{c1-2}$  cantilever load (N)      The diameter of the indexing circle of the transmission components (sprocket, gear, pulley, etc.) (mm)  
1=represents input axis       $K_r=1$  chain drive  
2=represents output shaft       $K_r=1.25$  gear transmission  
Torque on  $M_{r1-2}$  axis (Nm)       $K_r=1. -2.0$  V-belt drive  
If it is necessary to extend the working life, select the life coefficient in Table (A7).

工作寿命 working life	2500 h	5000 h	10000 h	15000 h	25000 h	50000 h	100000 h
$f_L$	0.66	0.81	1.00	1.13	1.32	1.62	2.00



c1) 输出轴

对于作用在轴中点的负载，需要按以下公式校核：

**Output shaft**

For the load acting on the midpoint of the axis, it needs to be verified according to the following formula:

$$R_{n2} \geq R_{c2} \times f_L \quad (18)$$

这里  $R_{n2}$  是指轴中点上的许用载荷，在额定值表中列出。

若悬臂载荷不在轴中点上，除FZ 型式外，确定偏移距离X，在相关图表中查找径向载荷位置系数  $f_{x2}$  (后面有各齿轮箱的安装图)。

必须满足以下条件：

Here,  $R_{n2}$  refers to the allowable load at the midpoint of the shaft, which is listed in the rated value table.

If the cantilever load is not at the midpoint of the axis, except for the FZ type,

determine the offset distance X and search for the radial load in the relevant chart

Position coefficient  $f_{x2}$  (installation diagrams for each gearbox are provided later). The following conditions must be met:

$$R_{x2} = R_{n2} \times f_{x2} \geq R_{c2} \times f_L \quad (19)$$

**VK 输出**

确定：

径向载荷  $R_{o2}$

轴向载荷  $A_{z2}$

载荷  $R_{e2}$  的偏移距离 X

查询相应齿轮箱的图表，确定与距离 x 相对应，

并且  $A_{o2}/R_{o2}$  比值接近  $A_{n2}/R_{n2}$  比值的径向载荷  $R_{x2}$ 。

必须满足以下条件：

**VK output**

determine:

Radial load  $R_{o2}$

Axial load  $A_{z2}$

Offset distance X of load  $R_{e2}$

Query the chart of the corresponding gearbox to determine the radial load  $R_{x2}$

that corresponds to distance x and has an  $A_{o2}/R_{o2}$  ratio close to the  $A_{n2}/R_{n2}$  ratio.

The following conditions must be met:

$$R_{x2} \geq R_{c2} \quad (20)$$

图表中的值适用于：

$n_2 = 10 \text{ rpm}$

10000 小时理论工作寿命

对于不同的输出转速  $n_2$  和工作寿命，需要考虑：

表 (A8) 中所示的速度系数  $f_{n2}$

The values in the chart are applicable to:

$n_2 = 10 \text{ rpm}$

Theoretical working life of 10000 hours

For different output speeds  $n_2$  and working lifetimes, it is necessary to consider:

The velocity coefficient  $f_{n2}$  shown in Table (A8)

$n_2$	1	2.5	5	10	15	25	50	100
$f_{n2}$	2.0	1.51	1.23	1.00	0.88	0.76	0.62	0.50

(A8)

表 (A7) 中所示的工作寿命系数  $f_L$  必须满足以下条件：

The working life coefficient  $f_L$  shown in Table (A7) must meet the following conditions:

$$R_{n2} \times f_{n2} \geq R_{c2} \times f_L \quad (21)$$

c2) 输入轴

根据由公式 (17) 所得的载荷  $R_{c1}$  值，

在减速箱图表中查找确定许用载荷  $R_{n1}$  和载荷的轴向偏移距离 x。

必须满足以下条件：

Input shaft

According to the load  $R_{c1}$  value obtained from formula (17),

Find and determine the allowable load  $R_{n1}$  and the axial offset distance x of the load in the gearbox chart.

The following conditions must be met:

$$R_{n1} \geq R_{c1} \quad (22)$$

图表中的值适用于：

输入转速  $n_1=1000\text{rpm}$

10000小时理论工作寿命

对于不同的输入转速和工作寿命，需要考虑：

表 (A9) 中所示的速度系数  $f_{n1}$

The values in the chart are applicable to:

Input speed  $n_1=1000\text{rpm}$

Theoretical working life of 10000 hours

For different input speeds and operating lifetimes, it is necessary to consider:

The velocity coefficient  $f_{n1}$  shown in Table (A9)

$n_1$	500	750	900	1200	1500	1800
$f_{n1}$	1.23	1.09	1.03	0.95	0.89	0.84

(A9)

表 (A7) 中所示的工作寿命系数  $f_L$ ：

必须满足以下条件：

The working life coefficient  $f_L$  shown in Table (A7):

The following conditions must be met:

$$R_{n1} \times f_{n1} \geq R_{c1} \times f_L \quad (23)$$

d) 轴向载荷

计算轴上所承受的轴向载荷  $A_{z2}$  的大小和方向。对于拟选减速箱，根据输出类型和轴向载荷的方向确定调整系数  $f_{a2}$ ，轴向力的方向以 (+) 和 (-) 表示，如下图所示：

**Axial load**

Calculate the magnitude and direction of the axial load  $A_{z2}$  borne on the axis.

For the proposed gearbox, based on the output type and axial load

The direction of the load determines the adjustment coefficient  $f_{a2}$ ,

and the direction of the axial force is represented by (+) and (-), as shown in the following figure:

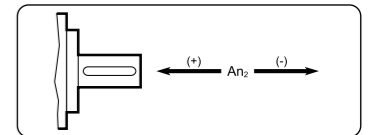

由  $R_{n2}$  和  $f_{a2}$  确定许用轴向载荷  $A_{n2}$ ：

Determine the allowable axial load  $A_{n2}$  from  $R_{n2}$  and  $f_{a2}$ ：

$$A_{n2} = R_{n2} \times f_{a2} \quad (24)$$

从表 (A7) 中选择与轴承的预期寿命相应的调整系数  $f_L$ 。在下表中查出由应用的负载特性确定的轴向负载系数  $K_a$ ：

Select the adjustment coefficient  $f_L$  corresponding to the expected life of the bearing from Table (A7).

Find the axial load coefficient  $K_a$  determined by the applied load characteristics in the following table:

	负载特性 Load characteristics		
	均匀负载 Uniform load	中等负载 Moderate Load	重负载 Heavy load
$K_a$	1.0	1.25	1.5

确定了所有系数后，要校核满足以下条件：

After determining all coefficients,

it is necessary to verify that the following conditions are met:

$$A_{c2} \times f_L \times K_a \leq A_{n2} \quad (25)$$

如果同时有轴向力和径向力，请与恒齿的技术部联系。

If there are both axial and radial forces, please contact Evergear's technical department.



## 14 选择电机 Select motor

a) 确定以下参数后，根据公式计算齿轮箱所需的输入功率：

所需转矩  $M_{r2}$   
输出转速  $n_2$   
效率  $\eta_d$

$$P_{r1} = \frac{M_{r2} \times n_2}{9550 \times \eta_d} \quad (26)$$

a) After determining the following parameters, calculate the required input power of the gearbox according to the formula:

Required torque  $M_{r2}$   
Output speed  $n_2$   
Efficiency  $\eta_d$

表 (A2) 列出了不同齿轮箱的效率  $\eta_d$  值。

Table (A2) lists the efficiency  $\eta_d$  values of different gearboxes.

b) 按照以下条件，在电机选型表中选择合适的电机：

b) Select the appropriate motor from the motor selection table according to the following conditions:

$$P_n \geq P_{r1} \quad (27)$$

对于非连续工作制S1条件下使用的电机，电机额定值可以应用调节系数  $f_m$  调整，见表 (A5) 所示。  
四极电机或更低转速电机优先选择。

For motors used under the S1 condition of non continuous operation, the rated value of the motor can be adjusted using the adjustment factor  $f_m$ , as shown in Table (A5).  
Four pole motor or lower speed motor is preferred.

Four pole motor or lower speed motor is preferred.

## 15 安装 Install

为保证齿轮箱正确可靠运行，需要遵守几条安装准则。

在此列出的准则可以作为齿轮箱选型向导。

我们的销售部门提供了齿轮箱的安装、使用和维护手册，遵循手册中的准则，就能正确有效的进行安装。

To ensure the correct and reliable operation of the gearbox, several installation guidelines need to be followed.

The criteria listed here can serve as a guide for gearbox selection.

Our sales department provides installation, use, and maintenance manuals for gearboxes.

By following the guidelines in the manual, correct and effective installation can be carried out.

下面是安装准则的简要描述：

Here is a brief description of the installation guidelines:

a) 固定：

将齿轮箱放在一个足够硬的平面上，结合面需要经过加工平坦的。

对法兰安装的带花键空心输出轴的齿轮箱尤其重要。

在输出端有高径向载荷的应用中，推荐用法兰安装，因为这些齿轮箱具双向直径对这个安装型式有好处。

保证齿轮箱适合于要求的安装位置。

使用8.8或更高等级的螺栓保证齿轮箱的安全。拧紧螺栓至相应图表中规定的额定值。

当传递的转矩大于或等于给定的和当频繁的改变转向时，使用最低等级10.9的螺栓。

有的齿轮箱可以使用螺栓和销紧固。如果使用了销，插入装配齿轮箱的装置的销的部分至少为它的直径1.5倍。

a) Fixed:

Place the gearbox on a sufficiently hard surface, and the joint surface needs to be machined flat.

It is particularly important for gearboxes with hollow output shafts with flower keys installed on flanges.

In applications with high radial loads at the output end, flange installation is recommended because these gearboxes have dual guide diameters that are beneficial for this installation type.

Ensure that the gearbox is suitable for the required installation position.

Use bolts of grade 8.8 or higher to ensure the safety of the gearbox. Tighten the bolts to the rated value specified in the corresponding chart.

When the transmitted torque is greater than or equal to the given value and when the steering is frequently changed,

use bolts with a minimum grade of 10.9. Some gearboxes can be fastened with bolts and pins. If a pin is used,

the part of the pin inserted into the device for assembling the gearbox should be at least 1.5 times its diameter.

b) 连接关系

装配传动装置零件到齿轮箱上时，禁止用铁锤或类似的工具敲打。为了压入零件，可使用

维护螺钉和轴端的螺纹。在装配之前务必擦掉轴上的油脂或防锈剂。

旋转方向

在电机接线前请注意输入/输出轴的布局，如下图所示：

b) Connection relationship

When assembling transmission components onto the gearbox, it is forbidden to use hammers or similar tools to strike.

To press in the parts, it is possible to Use maintenance screws and shaft end threads.

Be sure to wipe off the grease or rust inhibitor on the shaft before assembly.

Rotation direction

Please pay attention to the layout of the input/output shaft before wiring the motor, as shown in the following figure:

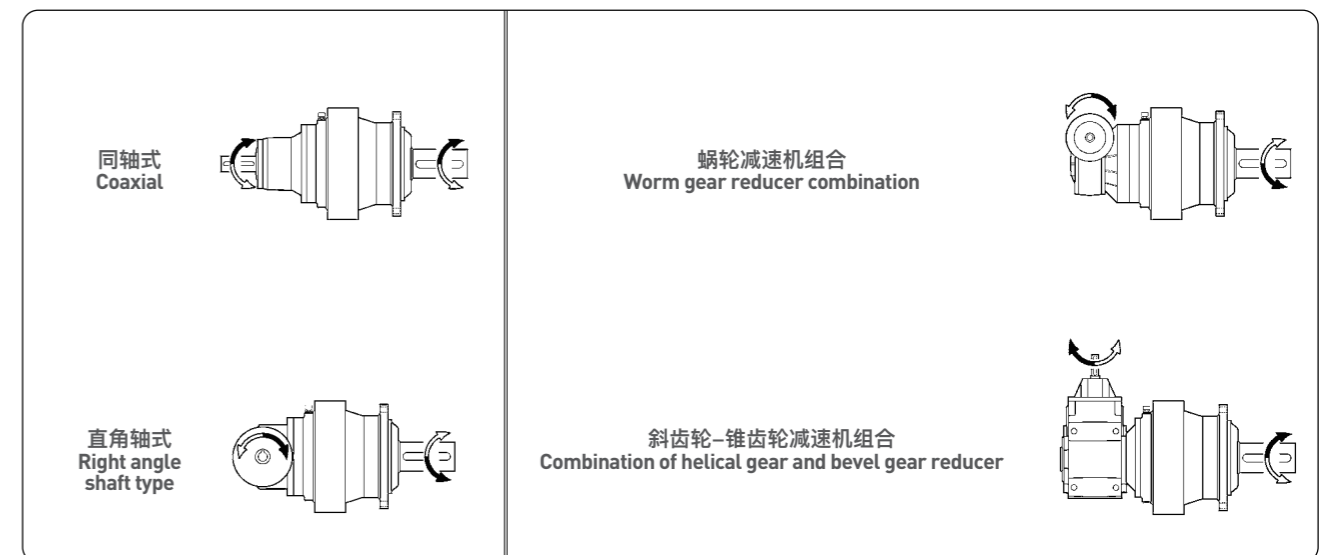

(A10)

c) 油漆

使用和齿轮箱的底漆相适应的油漆，请看：供货条件。

在油漆以前，将装在轴上的密封件保护好。

与溶剂接触会损坏密封件导致随后的漏油。

c) Paint

Please refer to the supply conditions for using paint that is compatible with the primer of the gearbox.

Before painting, protect the seals installed on the shaft.

Contact with solvents can damage seals and lead to subsequent oil leakage.



## d) 润滑

在投入运转之前，在齿轮箱中装入建议的型号和数值的润滑油（请看：润滑）。液面可以通过相宜的闷塞检验，闷塞每个齿轮箱都有，根据指定安装位置设置。注意：组合齿轮箱为行星级和蜗轮（3/V 系列）或斜齿轮单元（3 /A系列）配置单独的润滑。终身润滑齿轮箱在工厂里预装了合成油（见表A26），不必执行上述操作。

## d) Lubrication

Before putting into operation, fill the gearbox with the recommended type and value of lubricating oil (see: lubrication). The liquid level can be checked by appropriate sealing plugs, which are installed in each gearbox according to the designated installation position. Attention: The combination gearbox is equipped with separate lubrication for planetary and worm gears (3/V series) or helical gear units (3/A series). The lifelong lubrication gearbox is pre installed with synthetic oil in the factory (see Table A26), so there is no need to perform the above operation.

16 维护  
Maintenance

工作50小时后需要检查安装螺栓是否有松动。首次换油必须在工作100—150小时后进行。随后，每工作2000—3000小时更换润滑油，取决于应用情况。也可以一年换一次油。然而，必须每隔一定时间检查油面并按规定填油。在间歇工作制时应每月检查设备，连续工作时需要经常检查。

After working for 50 hours, it is necessary to check whether the installation bolts are loose. The first oil change must be carried out after working for 100-150 hours. Subsequently, the lubricating oil should be replaced every 2000-3000 hours of operation, depending on the application situation. You can also change the oil once a year. However, the oil level must be checked at regular intervals and filled according to regulations. During intermittent work, equipment should be inspected monthly, and during continuous work, regular inspections are required.

17 储存  
Storage

遵守以下说明确保产品的正确存储：

- 不要储存在户外露天或过于潮湿的地方。
- 始终在设备和地板之间垫有木板、木材或其它材料。齿轮箱不得与地板直接接触。
- 对于存放时间超过60天的齿轮箱，所有加工面如法兰、轴和联轴器必须要涂上一防锈产品（Mobilarm 248 或等效产品）。
- 当齿轮箱可能存放超过6个月时，必须进行以下特别检查：  
所有已加工部件要涂上黄油防止生锈。  
放置齿轮箱时必须使通气塞处于顶部并注满润滑油（不适用于终身润滑齿轮箱）。在齿轮箱投入运转之前，重新注入适当数量和型号的润滑油（表A25-A26）。

Follow the following instructions to ensure proper storage of the product: Do not store outdoors or in excessively humid places.

- Always place wooden boards, woods, or other materials between the equipment and the floor. The gearbox must not come into direct contact with the floor.
- For gearboxes stored for more than 60 days, all machined surfaces such as flanges, shafts, and couplings must be coated with an anti rust product (Mobilarm 248 or equivalent).
- When the gearbox may be stored for more than 6 months, the following special inspections must be carried out: All processed parts should be coated with butter to prevent rusting. When placing the gearbox, the vent plug must be at the top and filled with lubricating oil (not applicable to lifelong lubrication gearboxes). In the gearbox Before putting into operation, refill the appropriate amount and model of lubricating oil (Table A25-A26).

18 供货条件  
Supply conditions

齿轮箱供货标准：

- 安装结构符合订单中所规定的安装位置的要求；
- 无润滑。内部零件受到测试用润滑油膜的保护（类型 SHELL ENSIS OIL N）；
- 油漆打底层涂有灰色水基抗氧化剂类型为 Idrayon Primer – Ral 7042 / C441。安装表面不涂漆。外面末道漆由客户要求而定；
- 附带制造厂测试说明书；
- 适当包装；
- 提供用于安装IEC电机的配件；
- 需润滑齿轮箱在制造厂内装满润滑油。

Gearbox supply standard:



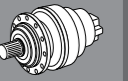
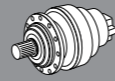





- The installation structure meets the requirements of the installation position specified in the order;
- No lubrication. Internal components are protected by a lubricating oil film for testing (type SHELL ENSIS OIL N);
- The base layer of the paint is coated with a gray water-based antioxidant type Idrayon Primer - Ral 7042/C441. The installation surface is not painted. The final coat of paint on the outside is determined by the customer's requirements;
- Comes with manufacturer's testing manual;
- Proper packaging;
- Provide accessories for installing IEC motors;
- The gearbox needs to be lubricated and filled with lubricating oil in the manufacturing plant.



19 型号说明  
Instruction for Models

EQ3 11 L 2 16.7 HZ

输出结构  
OUTPUT

	MZ: 带花键实心轴输出 Solid shaft output with splines		MC: 带平键实心轴输出 Solid shaft output with flat key
	HZ: 带花键加强型实心轴输出 Solid shaft output with spline reinforcement		HC: 带平键加强型实心轴输出 Reinforced solid shaft output with flat key
	PZ: 地脚安装带花键实心轴输出 Foundation installation with spline solid shaft output		PC: 地脚安装带平键实心轴输出 Anchor installation with flat key solid shaft output
	FZ: 带花键空心轴输出 Hollow shaft output with spline		VK: 搅拌机用加强型带键实心轴输出 Blender with reinforced key solid shaft output
	FP: 配收缩盘空心轴输出 Hollow shaft output with shrink disc		

速比  
填写选定图表中的传动比（包括小数点和小数）  
如：1/5.33=5.33 1/44.6=44.6 1/131=131  
speed ratio  
Fill in the transmission ratio in the selected chart (including decimal point and decimals)  
For example: 1/5.33=5.33 1/44.6=44.6 1/131=131

传动级数 1-2-3-4  
Transmission stages 1-2-3-4

结构型式  
Structural style

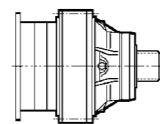

L=同轴式  
L=coaxial type

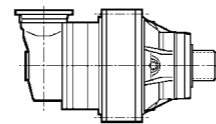

R=直角轴式  
R=Right angled shaft type

齿轮箱机座号  
Gearbox machine base number  
00=300 06=306 11=311 17=317  
01=301 07=307 13=313 18=318  
03=303 09=309 15=315 19=319  
05=305 10=310 16=316 21=321

减速机系列名  
Gearbox series name

P180 A W0A ... ..

可选项  
密封件材料  
标准=NITRILBUTADIENE  
PV=VITON  
只用于直角轴式  
输入转向的选择  
RA=左旋  
RO=右旋  
Optional  
Sealing material  
Standard=NITRILBUTADIENE  
PV=VITON  
Only used for right angle shaft type  
Input the selection of steering direction  
RA=Left Rotation  
RO=Right Rotation



外置冷却系统  
External cooling system

输出接口型式  
Output interface type



P...=小齿轮  
P...=Small gear



BOA=花键棒  
BOA=Spline Rod



MOA=套筒联轴节  
MOA=Sleeve Coupling



GOA=收缩盘  
GOA=Shrink Plate



WOA=法兰  
WOA=flange

安装位置  
Installation position

输入型式  
Input type



带平键输入轴  
Input shaft with flat key  
V01A=Φ24  
V01B=Φ38  
V05B=Φ48  
V06B=Φ60  
V07B=Φ80  
V11B=Φ80



IEC电机连接  
IEC motor connection  
P+电机机座号  
P+motor frame number  
(80, 90, 100, 132, 160...)



装有紧凑型电机的一体式齿轮减速电机：S2-, S3-, S4-适用于307和更小的型号  
Integrated gear reduction motor with compact motor:  
S2-, S3-, S4- suitable for 307 and smaller models

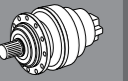
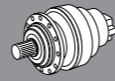

20 安装位置  
Installation position

只有再安装位置也指定的时候产品命名才是完整的。  
同轴式减速机请参阅表 (A11) ， 直角轴式减速机请参阅表 (A12) 。  
The product naming is only complete when the installation location is also specified.  
Please refer to Table (A11) for coaxial reducers and Table (A12) for right angle shaft reducers.

同轴式减速机 Coaxial reducer

(A11)

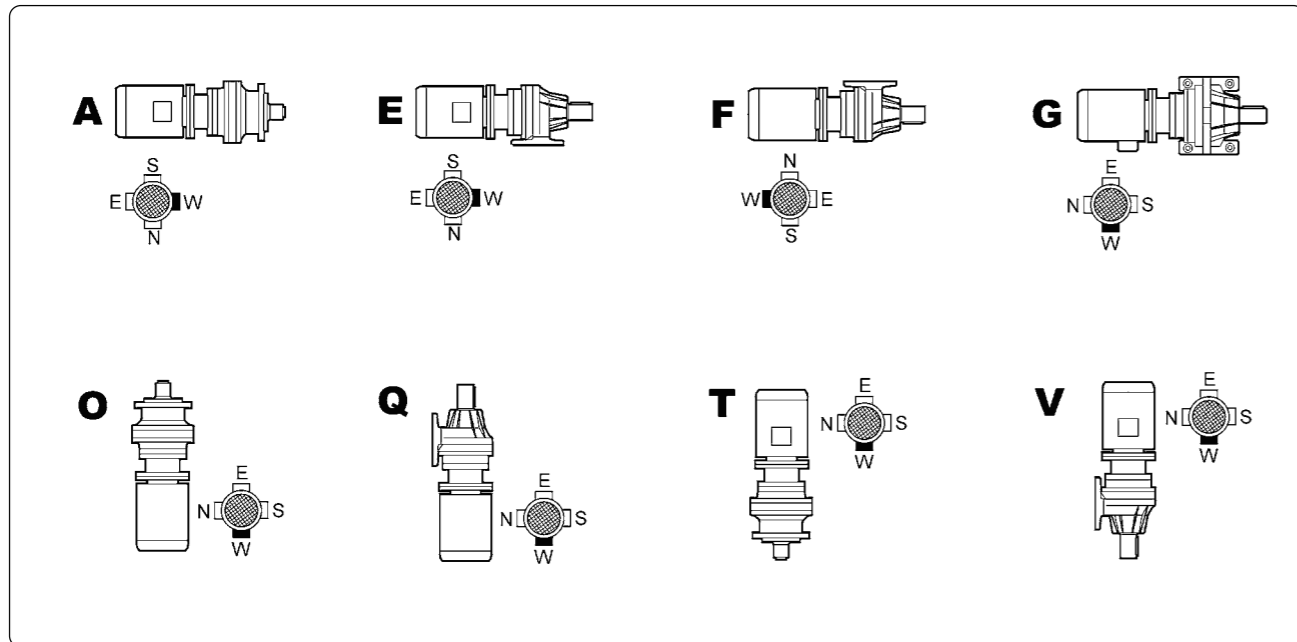

直角轴式减速机  
Right angle shaft reducer

(A12)

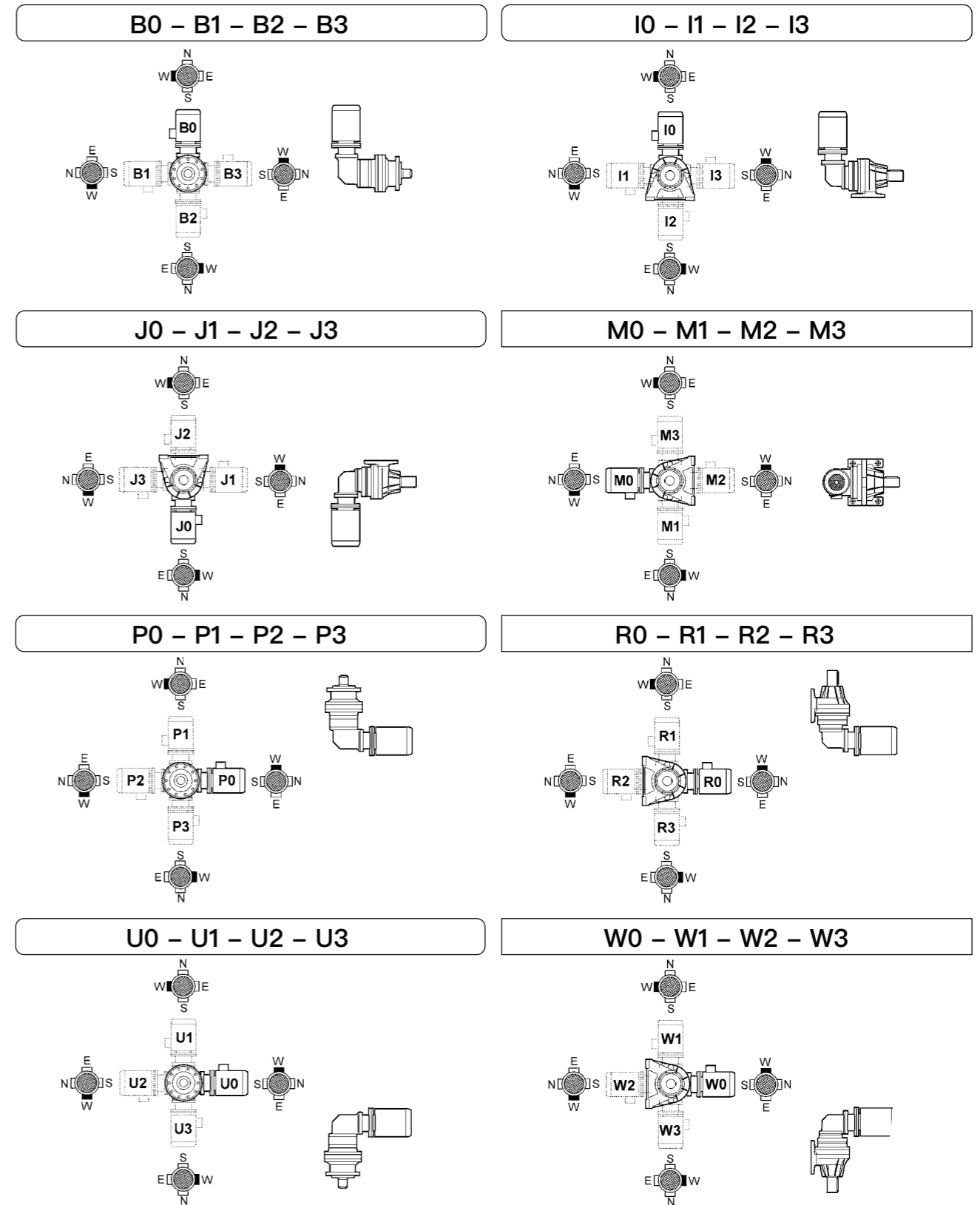

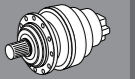
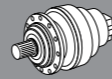

21 润滑  
lubrication

齿轮箱采用润滑油润滑。对指定垂直安装的齿轮箱，鉴于润滑油可能不能保证最上面的轴承的可靠润滑，因此采用另外的润滑措施。在运行以前，在齿轮箱中注入适量的润滑油，润滑油的粘性根据列表（A13）选择。齿轮箱通常装备有注油孔，标高和放油塞。因而在订购齿轮箱的时候必须指定安装位置。表（A13）列出了一般应用中建议采用的润滑油的牌子和型号。  
注意：对于非常规工作条件的应用，请征询制造厂的意见。工作油温不能超过80°C。  
本样本中列出的齿轮箱润滑油数量只是估计值。根据订货时指定的安装位置设置油位塞的位置以保证正确注油，齿轮箱注满润滑油至油位塞。如果传输功率超过齿轮箱的热容量，必须提供外置冷却装置（见：外置冷却系统）。

The gearbox is lubricated with lubricating oil. For the gearbox installed vertically, considering that lubricating oil may not guarantee reliable lubrication of the topmost bearing, alternative lubrication measures are adopted. Before operation, inject an appropriate amount of lubricating oil into the gearbox, and select the viscosity of the lubricating oil according to the list (A13). Gearboxes are usually equipped with oil injection holes, elevations, and drain plugs. Therefore, the installation position must be specified when ordering the gearbox. Table (A13) lists the brands and models of recommended lubricants for general applications. Attention: For applications under unconventional working conditions, please consult the manufacturer's opinion. The working oil temperature should not exceed 80 °C. The quantity of gearbox lubricating oil listed in this sample is only an estimate. Set the position of the oil level plug according to the installation location specified at the time of ordering to ensure correct oil filling. Fill the gearbox with lubricating oil until the oil level plug is reached. If the transmission power exceeds the thermal capacity of the gearbox, an external cooling device must be provided (see: External Cooling System).

注意：组合齿轮箱和减速电机为行星级和蜗轮齿轮箱（3/V 系列）或斜齿轮减速箱（3/A 系列）配置单独的润滑。  
Attention: The combination gearbox and reduction motor are equipped with separate lubrication for planetary and worm gear gearboxes (3/V series) or helical gear reduction gearboxes (3/A series).

(A13)

行星减速级 Planetary deceleration stage			
ISO 标准 3448 E.P. 级 ISO standard 3448 E.P. grade			
环境温度 Ambient temperature	-10°C / +30°C	+10°C / +45°C	-20°C / +60°C
	ISO VG 150	ISO VG 220	ISO VG 150-220
<b>SHELL</b>	<b>OMALA EP150</b>	<b>OMALA EP220</b>	<b>TIVELA OIL S</b>
AGIP	BLASIA150	BLASIA 220	BLASIA SX220
ARAL	DEGOL BG 150	DEGOL BG 220	DEGOL PAS 150-220
BP	ENERGOL GR XP 150	ENERGOL GR XP 220	EVERSYN EXP 150-220
CASTROL	ALPHA SP 150	ALPHA SP 220	ALPHASYN EP 150-220
CEPSA	ENGRANAJES HP 150	ENGRANAJES HP 220	ENGRANAJES HPX 150-220
CHEVRON	N.L. GEAR COMPOUNDS EP 150	N.L. GEAR COMPOUNDS EP 220	TEGRA SYNTHETIC GEAR EP 150-200
ESSO	SPARTAN EP 150	SPARTAN EP 220	SPARTAN S EP 150-220
FUCHS	RENOLIN CKC 150	RENOLIN CKC 220	RENOLIN UNISYN CKC 150-220
KLUBER	KLUBEROIL GEM1-150	KLUBEROIL GEM1-220	KLUBERSYNT EG 4-150 / 4-220
Q8	GOYA 150	GOYA 220	EL GRECO 220
MOBIL	MOBILGEAR 600 XP 150	MOBILGEAR 600 XP 220	MOBILGEAR SHC XMP 150-220
MOLYCOTE	L-0115	L-0122	L-2115 / L-2122
REPSOL	SUPER TAURO 150	SUPER TAURO 220	SUPER TAURO SINTETICO 150-220
TOTAL	CARTER EP 1500	CARTER EP 2200	CARTER SH 150-220

齿轮箱最高的温度不得超过70-75摄氏度  
The maximum temperature of the gearbox shall not exceed 70-75 degrees Celsius

EQ3\_L-EQ3\_R系列减速机油堵位置  
Location of oil blockage in the EQ3\_L-EQ3\_R series reducer

(A14)

所有齿轮箱

- 1 注油塞/透气塞
- 2 油位塞
- 3 放油塞

同轴式1级行星齿轮箱

- 1A 注油塞/透气塞
- 3A 放油塞

直角轴式2级行星齿轮箱

- 1B 注油塞/透气塞
- 3B 放油塞

All gearboxes

- 1 Oil filling plug/breathable plug
- 2 Oil level plug
- 3 drain plug

Coaxial 1-stage planetary gearbox

- 1A oil filling plug/breathable plug
- 3A oil drain plug

Right angle shaft type two-stage planetary gearbox

- 1B oil filling plug/breathable plug
- 3B oil drain plug

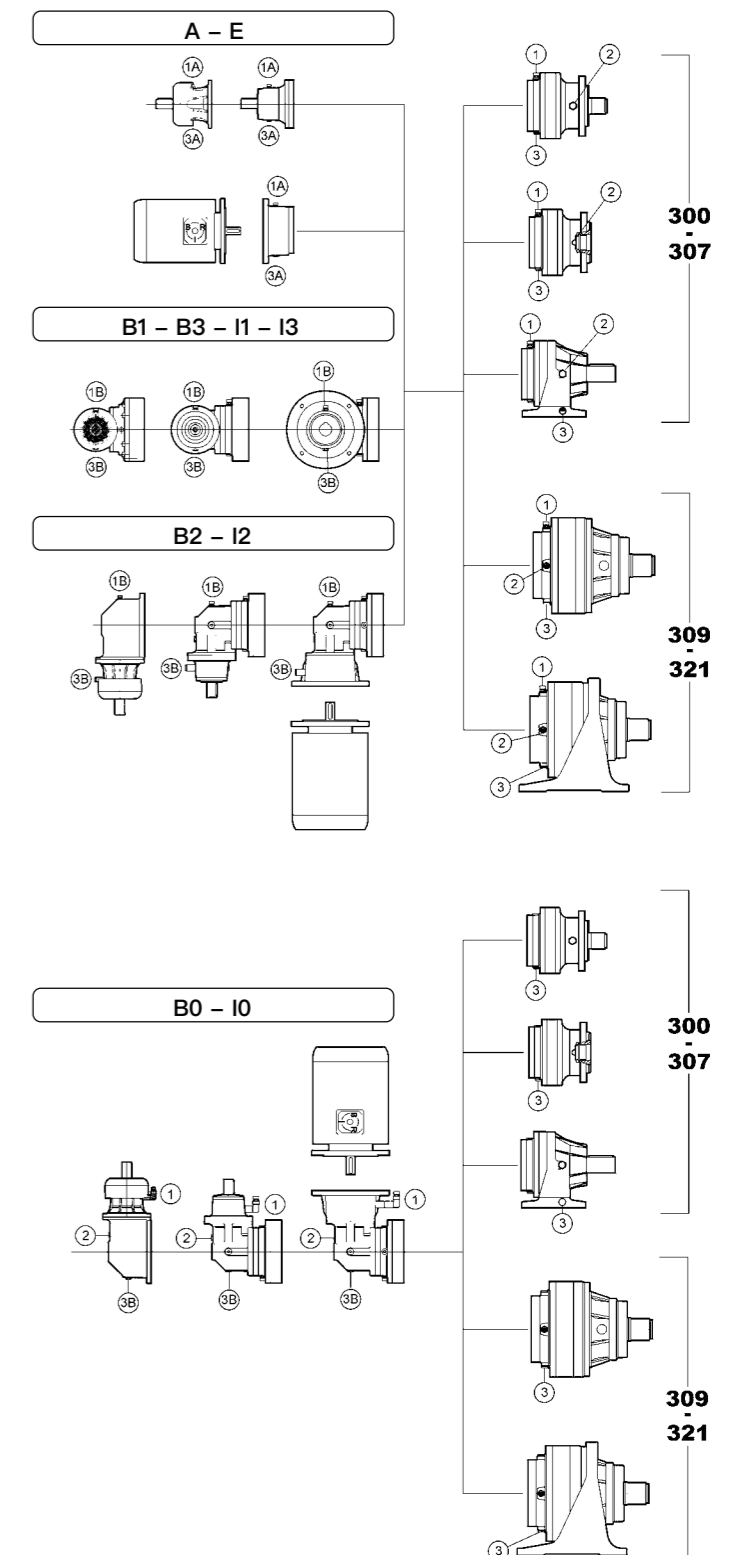

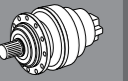
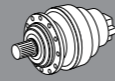

EQ3\_L-EQ3\_R系列减速机油堵位置  
Location of oil blockage in the EQ3\_L-EQ3\_R series reducer

(A15)

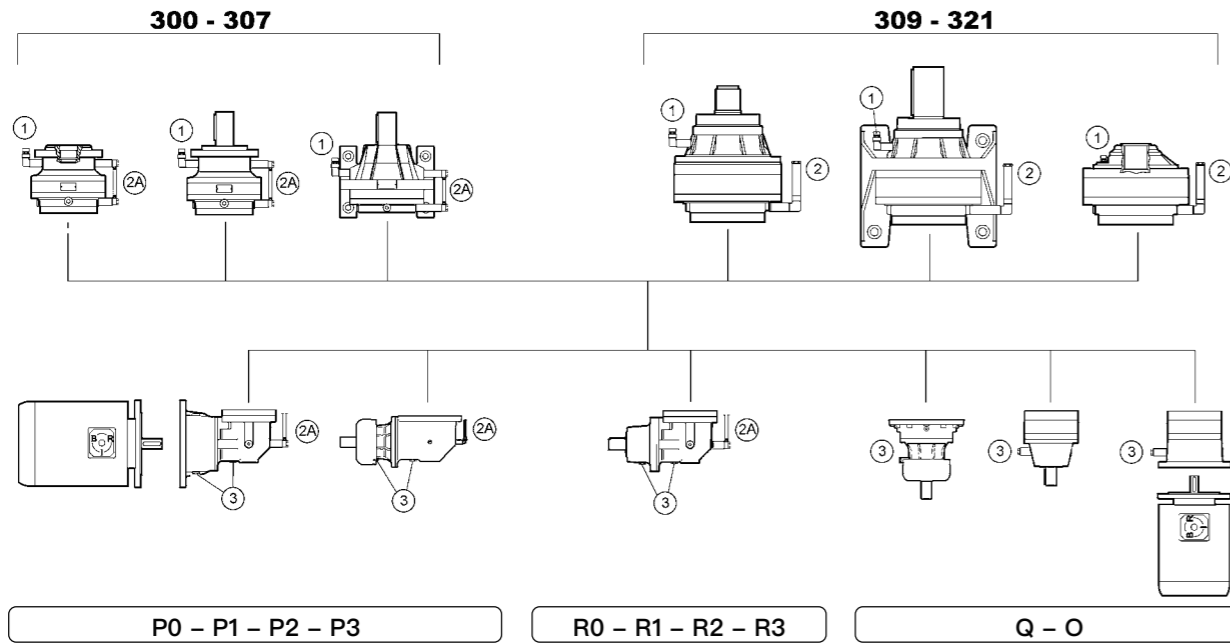

- |              |  |
|--------------|--|
| <b>所有齿轮箱</b> | <b>All gearboxes</b>                               |
| 1 注油塞/透气塞    | 1 Oil filling plug/breathable plug                 |
| 2 油位塞        | 2 Oil level plug                                   |
| 2A 透明的油位管    | 2A Transparent oil level tube                      |
| 3 放油塞        | 3 oil drain plug                                   |
| 5 连续工况中缓冲油罐  | 5 Buffer oil tank in continuous working conditions |

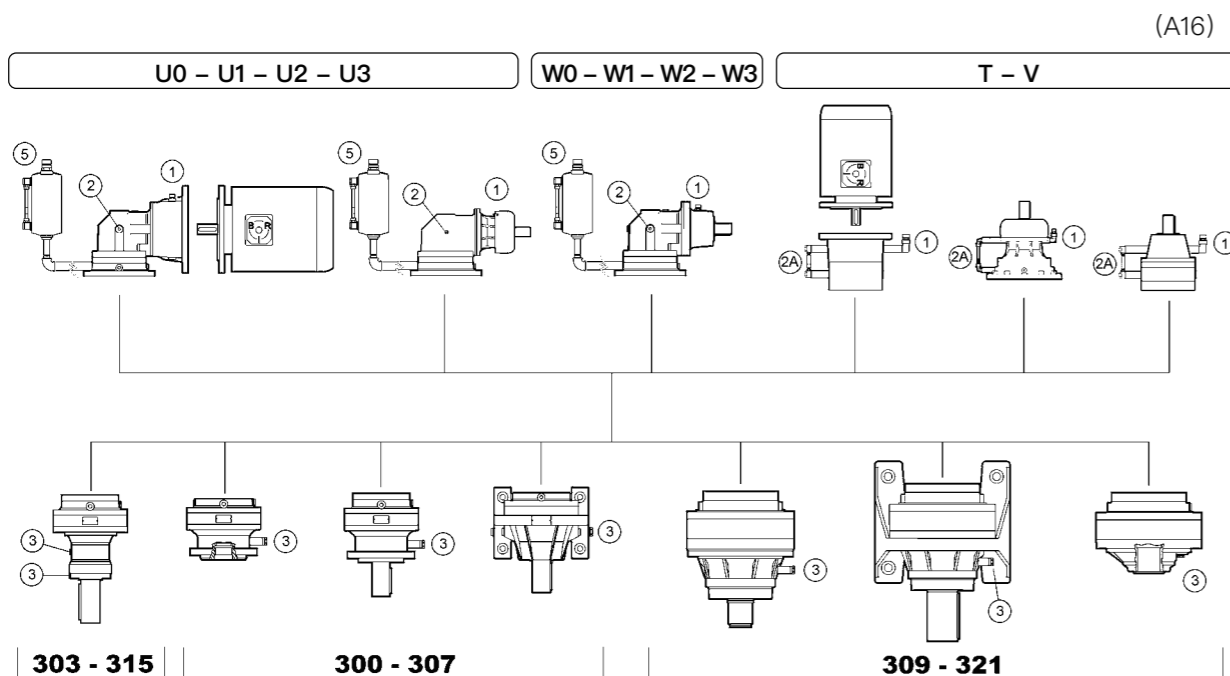

(A16)

EQ3\_L-EQ3\_R系列润滑油量 (l)  
EQ3\_L-EQ3\_R series lubricating oil quantity (l)

(A17)

型号 model		安装位置 Installation position		
		A	T	O
EQ300	L1	0.6	1.0	0.9
	L2	0.9	1.3	1.2
	L3	1.2	1.6	1.5
	L4	1.5	1.9	1.8
EQ301	L1	0.8	1.2	1.1
	L2	1.1	1.5	1.4
	L3	1.4	1.8	1.7
	L4	1.7	2.1	2.0
EQ303	L1	1.3	2.3	2.0
	L2	1.6	2.6	2.3
	L3	1.9	2.9	2.6
	L4	2.2	3.2	2.9
EQ304	L1	1.4	2.4	2.2
	L2	1.9	2.9	2.7
	L3	2.2	3.2	3.0
	L4	2.5	3.5	3.3
EQ305	L1	1.6	2.6	2.4
	L2	2.1	3.1	2.9
	L3	2.4	3.4	3.2
	L4	2.7	3.7	3.5
EQ306	L1	2.5	3.5	3.2
	L2	3.3	4.3	4.0
	L3	3.6	4.6	4.3
	L4	3.9	4.9	4.6
EQ307	L1	3.5	5.0	4.5
	L2	4.5	6.0	5.5
	L3	5.0	6.5	6.0
	L4	5.3	6.8	6.3
EQ309	L1	4.0	5.5	5.0
	L2	5.0	6.5	6.0
	L3	5.5	7.0	6.5
	L4	5.8	7.3	6.8
EQ310	L1	5.0	6.5	6.0
	L2	6.3	7.8	7.3
	L3	7.1	8.6	8.1
	L4	7.4	8.9	8.4
EQ311	L1	7.0	12	10
	L2	9.0	14	12
	L3	10	15	13
	L4	11	16	14
EQ313	L1	9.0	14	12
	L2	12	17	15
	L3	13	18	16
	L4	13	18	16
EQ314	L2	17	25	21
	L3	19	27	23
	L4	20	28	24
	L2	19	27	23
EQ315	L3	21	29	25
	L4	22	30	26
	L2	22	30	26
	L3	24	32	28
EQ316	L4	25	33	29
	L2	26	41	36
	L3	29	44	39
	L4	30	45	40
EQ317	L3	40	55	50
	L4	43	58	53
	L3	50	70	60
	L4	53	73	63
EQ318	L3	56	76	66
	L4	60	80	70

型号 model		安装位置 Installation position		
		B0	U_	P_
EQ300	R2	1.2	1.7	1.5
	R3	1.5	2.0	1.8
	R4	1.8	2.3	2.1
EQ301	R2	1.6	2.1	1.9
	R3	1.9	2.4	2.2
	R4	2.2	2.7	2.5
EQ303	R2	2.2	2.8	2.6
	R3	2.5	3.1	2.9
	R4	2.8	3.4	3.2
EQ304	R2	2.3	2.9	2.7
	R3	2.8	3.4	3.2
	R4	3.1	3.7	3.5
EQ305	R2	2.5	3.1	2.9
	R3	3.0	3.6	3.4
	R4	3.3	3.9	3.7
EQ306	R2	4.0	5.0	4.8
	R3	4.8	5.8	5.6
	R4	5.1	6.1	5.9
EQ307	R2	6.0	8.0	7.0
	R3	7.0	9.0	8.0
	R4	7.5	9.5	8.5
EQ309	R2	6.5	8.5	7.5
	R3	7.5	9.5	8.5
	R4	8.0	10	9.0
EQ310	R2	13	15	14
	R3	11	13	12
	R4	12	14	13
EQ311	R2	14	19	17
	R3	16	21	19
	R4	17	22	20
EQ313	R2	16	21	19
	R3	19	24	22
	R4	20	25	23
EQ314	R3	25	33	29
	R4	28	36	32
	R3	27	35	31
EQ315	R4	30	38	34
	R3	30	38	34
	R4	33	41	37
EQ316	R3	38	52	48
	R4	42	56	52
	R4	48	63	58

注：润滑油量只是估计的，再通过专用的塞子注入以后检查实际标高。

Note: The amount of lubricating oil is only an estimate, and the actual elevation will be checked after injection through a dedicated plug.

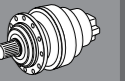
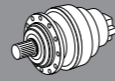

查阅额定值表说明  
Refer to the rated value table for instructions

①

Table for EQ300L with 1000 Nm output torque. Columns include input speed (n1), gear ratio (i), output speed (n2), input power (Pn1), output power (Pt), IEC motor frame numbers, and allowable cantilever loads (Rn2) for MC, MZ, HC/PC, HZ/PZ, and FZ configurations.

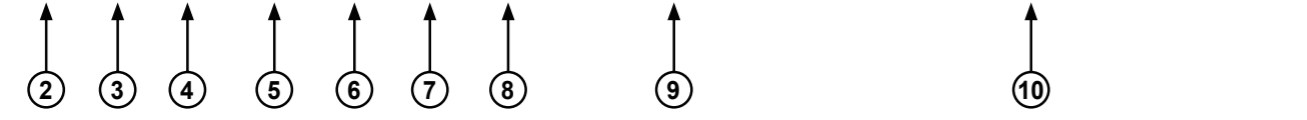

- 1 最大输出转矩。 1 Maximum output torque.
- 2 齿轮箱输入转速。 2 Input speed of gearbox.
- 3 同轴式齿轮箱的机座号。 3 Machine base number of coaxial gearbox.
- 4 传动比。 4 transmission ratios.
- 5 齿轮箱输出转速。 5 gearbox output speed.
- 6 齿轮箱额定输出转矩, 条件: 安全系数S=1 假设使用寿命10000小时。 6 Rated output torque of gearbox 6, condition: safety factor S=1, assuming a service life of 10000 hours.
- 7 齿轮箱额定输入转矩, 条件: 安全系数S=1 假设使用寿命10000小时。 7 Rated input torque of gearbox, condition: safety factor S=1, assuming a service life of 10000 hours.
- 8 齿轮箱热功率。 8 Gearbox thermal power.
- 9 可用的IEC电机的机座号。 9 available IEC motor frame numbers.
- 10 在输出轴上的允许悬臂荷载, 条件: 安全系数S=1 假设使用寿命10000小时 当作用力没有应用在轴中点, 按照具体齿轮箱的尺寸查看规定的图表。 10 Allowable cantilever load on the output shaft, condition: safety factor S=1. Assuming a service life of 10000 hours, it is assumed that no force is applied at the midpoint of the shaft. Refer to the specified chart based on the size of the gearbox.

Table for EQ300L with 1000 Nm output torque, continuing from the previous table. It lists detailed specifications for various gear ratios (300 L1 to 300 L4) and motor frame numbers, including input/output speeds, powers, and cantilever loads.

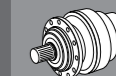
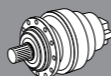

EQ300L							1000 Nm					
$n_1$ min <sup>-1</sup>		i	$n_2$ min <sup>-1</sup>	$m_{n2}$ Nm	$P_{n1}$ kW	Pt kW	IEC	$R_{n2}$ [N]				
								MC	MZ	HC/PC	HZ/PZ	FZ
900	300 L3	51.6	17.4	820	1.6	9.0	71 80 90 100 112 132	4690	4690	13000	15000	3090
	300 L3	63.2	14.2	830	1.4	9.0	71 80 90 100 112 132	5020	5020	13800	15900	3300
	300 L3	69.9	12.9	650	0.96	9.0	71 80 90 100 112 132	5190	5190	14300	16400	3410
	300 L3	77.5	11.6	840	1.1	9.0	71 80 90 100 112 132	5370	5370	14700	16900	3530
	300 L3	85.6	10.5	850	1.0	9.0	71 80 90 100 112 132	5550	5550	15100	17400	3650
	300 L3	105	8.6	860	0.85	9.0	71 80 90 100 112 132	5940	5940	16100	18500	3910
	300 L3	116	7.8	650	0.58	9.0	71 80 90 100 112 132	6140	6140	16600	19100	4040
	300 L3	131	6.9	870	0.69	9.0	71 80 90 100 112 132	6400	6400	17200	19800	4210
	300 L3	142	6.3	880	0.64	9.0	71 80 90 100 112 132	6570	6570	17600	20300	4320
	300 L3	177	5.1	890	0.52	9.0	71 80 90 100 112 132	7080	7080	18800	21600	4650
	300 L3	192	4.7	660	0.35	9.0	71 80 90 100 112 132	7270	7270	19300	22200	4780
	300 L3	221	4.1	920	0.43	9.0	71 80 90 100 112 132	7620	7620	20100	23100	5010
	300 L3	240	3.8	680	0.29	9.0	71 80 90 100 112 132	7830	7830	20600	23700	5150
	300 L3	299	3.0	710	0.24	9.0	71 80 90 100 112 132	8430	8430	22000	25300	5540
	300 L3	374	2.4	730	0.20	9.0	71 80 90 100 112 132	9080	9080	23600	27100	5970
	300 L4	330	2.7	990	0.32	7.2	71 80 90 100 112 132	8710	8710	22700	26100	5730
	300 L4	403	2.2	740	0.20	7.2	71 80 90 100 112 132	9310	9310	24100	27700	6120
	300 L4	447	2.0	1000	0.24	7.2	71 80 90 100 112 132	9640	9640	24900	28600	6340
	300 L4	494	1.8	1000	0.22	7.2	71 80 90 100 112 132	9960	9960	25600	29400	6550
	300 L4	558	1.6	1000	0.19	7.2	71 80 90 100 112 132	10400	10400	26600	30500	6820
	300 L4	616	1.5	1000	0.17	7.2	71 80 90 100 112 132	10700	10700	27400	31500	7050
	300 L4	755	1.2	1000	0.14	7.2	71 80 90 100 112 132	11500	11500	29100	33400	7540
	300 L4	819	1.1	1000	0.13	7.2	71 80 90 100 112 132	11800	11800	29800	34000	7750
	300 L4	942	0.96	1000	0.11	7.2	71 80 90 100 112 132	12000	12400	31000	34000	8000
	300 L4	1022	0.88	1000	0.10	7.2	71 80 90 100 112 132	12000	12500	31000	34000	8000
	300 L4	1108	0.81	860	0.08	7.2	71 80 90 100 112 132	12000	12500	31000	34000	8000
	300 L4	1275	0.71	1000	0.08	7.2	71 80 90 100 112 132	12000	12500	31000	34000	8000
	300 L4	1383	0.65	860	0.07	7.2	71 80 90 100 112 132	12000	12500	31000	34000	8000
	300 L4	1591	0.57	1000	0.07	7.2	71 80 90 100 112 132	12000	12500	31000	34000	8000
	300 L4	1725	0.52	860	0.05	7.2	71 80 90 100 112 132	12000	12500	31000	34000	8000
	300 L4	2153	0.42	860	0.04	7.2	71 80 90 100 112 132	12000	12500	31000	34000	8000
	300 L4	2692	0.33	1000	0.04	7.2	71 80 90 100 112 132	12000	12500	31000	34000	8000

EQ301L							1750 Nm					
$n_1$ min <sup>-1</sup>		i	$n_2$ min <sup>-1</sup>	$m_{n2}$ Nm	$P_{n1}$ kW	Pt kW	IEC	$R_{n2}$ [N]				
								MC	MZ	HC/PC	HZ/PZ	FZ
1400	301 L1	4.26	328	770	27	7.5	71 80 90 100 112 132	1760	1760	5390	6200	1160
	301 L1	5.77	243	800	21	7.5	71 80 90 100 112 132	1950	1950	5910	6790	1280
	301 L1	7.20	194	770	16.2	7.5	71 80 90 100 112 132	2100	2100	6310	7250	1380
	301 L1	9.00	156	580	9.7	7.5	71 80 90 100 112 132	2260	2260	6750	7750	1490
	301 L2	12.1	116	1050	13.5	7.5	71 80 90 100 112 132	2500	2500	7380	8480	1640
	301 L2	14.8	94	1120	11.8	7.5	71 80 90 100 112 132	2670	2670	7840	9010	1760
	301 L2	18.2	77	1190	10.2	7.5	71 80 90 100 112 132	2860	2860	8330	9580	1880
	301 L2	20.1	70	1170	9.1	7.5	71 80 90 100 112 132	2960	2960	8590	9870	1940
	301 L2	24.6	57	1300	8.2	7.5	71 80 90 100 112 132	3160	3160	9130	10500	2080
	301 L2	30.7	46	1370	6.9	7.5	71 80 90 100 112 132	3410	3410	9750	11200	2240
	301 L2	33.3	42	1300	6.1	7.5	71 80 90 100 112 132	3500	3500	9990	11500	2300
	301 L2	38.4	36	1310	5.3	7.5	71 80 90 100 112 132	3670	3670	10400	12000	2410
	301 L2	41.5	34	1300	4.9	7.5	71 80 90 100 112 132	3770	3770	10700	12300	2480
	301 L2	51.9	27.0	1300	3.9	7.5	71 80 90 100 112 132	4060	4060	11400	13100	2670
	301 L2	64.8	21.6	1150	2.8	7.5	71 80 90 100 112 132	4370	4370	12200	14000	2870
	301 L3	51.6	27.1	1470	4.6	7.5	71 80 90 100 112 132	4050	4050	11400	13100	2660
	301 L3	63.2	22.1	1520	3.9	7.5	71 80 90 100 112 132	4330	4330	12100	13900	2850
	301 L3	69.9	20.0	1300	3.0	7.5	71 80 90 100 112 132	4480	4480	12500	14300	2950
	301 L3	77.5	18.1	1560	3.2	7.5	71 80 90 100 112 132	4640	4640	12900	14800	3050
	301 L3	85.6	16.4	1580	2.5	7.5	71 80 90 100 112 132	4790	4790	13300	15200	3150

EQ301L							1750 Nm						
$n_1$ min <sup>-1</sup>		i	$n_2$ min <sup>-1</sup>	$m_{n2}$ Nm	$P_{n1}$ kW	Pt kW	IEC	$R_{n2}$ [N]					
								MC	MZ	HC/PC	HZ/PZ	FZ	
1400	301 L3	105	13.4	1630	2.5	7.5	71 80 90 100 112 132	5130	5130	14100	16200	3370	
	301 L3	116	12.1	1300	1.8	7.5	71 80 90 100 112 132	5300	5300	14500	16700	3490	
	301 L3	131	10.7	1680	2.1	7.5	71 80 90 100 112 132	5520	5520	15100	17300	3630	
	301 L3	142	9.9	1700	1.9	7.5	71 80 90 100 112 132	5670	5670	15400	17700	3730	
	301 L3	177	7.9	1720	1.6	7.5	71 80 90 100 112 132	6110	6110	16500	19000	4020	
	301 L3	192	7.3	1300	1.1	7.5	71 80 90 100 112 132	6280	6280	16900	19400	4130	
	301 L3	221	6.3	1730	1.3	7.5	71 80 90 100 112 132	6580	6580	17600	20300	4320	
	301 L3	240	5.8	1300	0.87	7.5	71 80 90 100 112 132	6760	6760	18100	20800	4440	
	301 L3	299	4.7	1310	0.71	7.5	71 80 90 100 112 132	7270	7270	19300	22200	4780	
	301 L3	374	3.7	1360	0.58	7.5	71 80 90 100 112 132	7840	7840	20600	23700	5150	
	301 L4	330	4.2	1810	0.91	6.0	71 80 90 100 112 132	7520	7520	19900	22900	4940	
	301 L4	403	3.5	1380	0.57	6.0	71 80 90 100 112 132	8040	8040	21100	24300	5280	
	301 L4	447	3.1	1920	0.71	6.0	71 80 90 100 112 132	8320	8320	21800	25000	5470	
	301 L4	494	2.8	1950	0.65	6.0	71 80 90 100 112 132	8600	8600	22400	25800	5650	
	301 L4	558	2.5	2000	0.59	6.0	71 80 90 100 112 132	8950	8950	23300	26700	5890	
	301 L4	616	2.3	2000	0.54	6.0	71 80 90 100 112 132	9260	9260	24000	27600	6090	
	301 L4	755	1.9	2000	0.44	6.0	71 80 90 100 112 132	9900	9900	25500	29300	6510	
	301 L4	819	1.7	2000	0.40	6.0	71 80 90 100 112 132	10200	10200	26100	30000	6690	
	301 L4	942	1.5	2000	0.35	6.0	71 80 90 100 112 132	10700	10700	27200	31300	7010	
	301 L4	1022	1.4	2000	0.32	6.0	71 80 90 100 112 132	11000	11000	27900	32100	7200	
	301 L4	1108	1.3	1630	0.24	6.0	71 80 90 100 112 132	11300	11300	28600	32900	7400	
	301 L4	1275	1.1	2000	0.26	6.0	71 80 90 100 112 132	11800	11800	29800	34000	7750	
	301 L4	1383	1.0	1700	0.20	6.0	71 80 90 100 112 132	12000	12100	30600	34000	7970	
	301 L4	1591	0.88	2000	0.21	6.0	71 80 90 100 112 132	12000	12500	31000	34000	8000	
	301 L4	1725	0.81	1700	0.16	6.0	71 80 90 100 112 132	12000	12500	31000	34000	8000	
	301 L4	2153	0.65	1700	0.13	6.0	71 80 90 100 112 132	12000	12500	31000	34000	8000	
	301 L4	2692	0.52	1700	0.10	6.0	71 80 90 100 112 132	12000	12500	31000	34000	8000	
	900	301 L1	3.48	259	830	23	9.0	71 80 90 100 112 132	1910	1910	5790	6660	1260
		301 L1	4.26	211	880	20	9.0	71 80 90 100 112 132	2040	2040	6160	7080	1340
		301 L1	5.77	156	920	15.5	9.0	71 80 90 100 112 132	2260	2260	6740	7750	1490
		301 L1	7.20	125	880	11.9	9.0	71 80 90 100 112 132	2430	2430	7210	8280	1600
		301 L1	9.00	100	660	7.1	9.0	71 80 90 100 112 132	2620	2620	7710	8850	1720
		301 L2	12.1	74	1180	9.8	9.0	71 80 90 100 112 132	2890	2890	8420	9680	1900
		301 L2	14.8	61	1280	8.6	9.0	71 80 90 100 112 132	3100	3100	8950	10300	2040
		301 L2	18.2	50	1350	7.5	9.0	71 80 90 100 112 132	3310	3310	9520</		

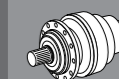
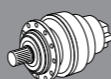

EQ301L							1750 Nm										
n <sub>1</sub>	i	n <sub>2</sub>	m <sub>n2</sub>	P <sub>n1</sub>	Pt	IEC	R <sub>n2</sub> [N]										
min <sup>-1</sup>		min <sup>-1</sup>	Nm	kW	kW		MC	MZ	HC/PC	HZ/PZ	FZ						
900	301 L4	558	1.6	2000	0.38	7.2	71	80	90	100	112	132	10400	10400	26600	30500	6820
	301 L4	616	1.5	2000	0.35	7.2	71	80	90	100	112	132	10700	10700	27400	31500	7050
	301 L4	755	1.2	2000	0.28	7.2	71	80	90	100	112	132	11500	11500	29100	33400	7540
	301 L4	819	1.1	2000	0.26	7.2	71	80	90	100	112	132	11800	11800	29800	34000	7750
	301 L4	942	0.96	2000	0.23	7.2	71	80	90	100	112	132	12000	12400	31000	34000	8000
	301 L4	1022	0.88	2000	0.21	7.2	71	80	90	100	112	132	12000	12500	31000	34000	8000
	301 L4	1108	0.81	1700	0.16	7.2	71	80	90	100	112	132	12000	12500	31000	34000	8000
	301 L4	1275	0.71	2000	0.17	7.2	71	80	90	100	112	132	12000	12500	31000	34000	8000
	301 L4	1383	0.65	1700	0.13	7.2	71	80	90	100	112	132	12000	12500	31000	34000	8000
	301 L4	1591	0.57	2000	0.13	7.2	71	80	90	100	112	132	12000	12500	31000	34000	8000
	301 L4	1725	0.52	1700	0.10	7.2	71	80	90	100	112	132	12000	12500	31000	34000	8000
	301 L4	2153	0.42	1700	0.08	7.2	71	80	90	100	112	132	12000	12500	31000	34000	8000
	301 L4	2692	0.33	1700	0.07	7.2	71	80	90	100	112	132	12000	12500	31000	34000	8000

EQ303L							2500 Nm													
n <sub>1</sub>	i	n <sub>2</sub>	m <sub>n2</sub>	P <sub>n1</sub>	Pt	P(IEC)	R <sub>n2</sub> [N]													
min <sup>-1</sup>		min <sup>-1</sup>	Nm	kW	kW		MC	MZ	HC/PC	HZ/PZ	FZ									
1400	303 L4	556	2.5	2750	0.82	6.0	71	80	90	100	112	132	160	-	-	27500	31700	47500	57100	17600
	303 L4	649	2.2	2220	0.56	6.0	71	80	90	100	112	132	160	-	-	29000	33400	49700	59800	18600
	303 L4	718	1.9	2080	0.48	6.0	71	80	90	100	112	132	160	-	-	29900	34600	51300	61700	19200
	303 L4	816	1.7	2720	0.55	6.0	71	80	90	100	112	132	160	-	-	31300	36100	53300	64100	20000
	303 L4	896	1.6	2150	0.40	6.0	71	80	90	100	112	132	160	-	-	32200	37200	54800	65900	20700
	303 L4	1018	1.4	2730	0.44	6.0	71	80	90	100	112	132	160	-	-	33600	38800	56900	68500	21600
	303 L4	1098	1.3	2220	0.33	6.0	71	80	90	100	112	132	160	-	-	34500	39800	58200	70000	22100
	303 L4	1278	1.1	2810	0.36	6.0	71	80	90	100	112	132	160	-	-	36000	41900	60900	73300	23300
	303 L4	1370	1.0	2290	0.28	6.0	71	80	90	100	112	132	160	-	-	36000	42000	62200	74000	23800
	303 L4	1586	0.88	2250	0.23	6.0	71	80	90	100	112	13	160	-	-	36000	42000	64000	74000	24000
	303 L4	1854	0.76	2300	0.21	6.0	71	80	90	100	112	132	160	-	-	36000	42000	64000	74000	24000
	303 L4	1991	0.70	2850	0.24	6.0	71	80	90	100	112	132	160	-	-	36000	42000	64000	74000	24000
	303 L4	2243	0.62	2000	0.15	6.0	71	80	90	100	112	132	160	-	-	36000	42000	64000	74000	24000
	303 L4	2799	0.50	2000	0.12	6.0	71	80	90	100	112	132	160	-	-	36000	42000	64000	74000	24000

EQ303L							2500 Nm													
n <sub>1</sub>	i	n <sub>2</sub>	m <sub>n2</sub>	P <sub>n1</sub>	Pt	P(IEC)	R <sub>n2</sub> [N]													
min <sup>-1</sup>		min <sup>-1</sup>	Nm	kW	kW		MC	MZ	HC/PC	HZ/PZ	FZ									
1400	303 L1	4.25	329	1120	40	11.0	-	-	-	-	132	160	180	200	5420	6250	11000	13200	3480	
	303 L1	5.33	263	1270	36	11.0	-	-	-	-	132	160	180	200	5840	6750	11800	14200	3750	
	303 L1	6.20	226	1100	27	11.0	-	-	-	-	132	160	180	200	6140	7090	12300	14800	3940	
	303 L1	7.50	187	1240	25	11.0	-	-	-	-	132	160	180	200	6550	7560	13000	15700	4200	
	303 L1	9.67	145	770	12.0	11.0	-	-	-	-	132	160	180	200	7120	8220	14100	16900	4570	
	303 L2	12.5	112	1450	18.0	9.0	71	80	90	100	112	132	160	-	-	7770	8970	15200	18300	4980
	303 L2	15.3	91	1490	15.1	9.0	71	80	90	100	112	132	160	-	-	8310	9590	16200	19500	5330
	303 L2	18.1	77	1770	15.2	9.0	71	80	90	100	112	132	160	-	-	8780	10100	17000	20400	5630
	303 L2	20.8	67	1560	11.7	9.0	71	80	90	100	112	132	160	-	-	9190	10600	17700	21300	5900
	303 L2	22.7	62	1970	13.5	9.0	71	80	90	100	112	132	160	-	-	9470	10900	18200	21900	6080
	303 L2	24.5	57	1830	11.6	9.0	71	80	90	100	112	132	160	-	-	9720	11200	18600	22400	6230
	303 L2	26.4	53	1720	10.1	9.0	71	80	90	100	112	132	160	-	-	9960	11500	19000	22900	6390
	303 L2	30.8	46	2110	10.7	9.0	71	80	90	100	112	132	160	-	-	10500	12100	19900	24000	6720
	303 L2	35.8	39	1760	7.7	9.0	71	80	90	100	112	132	160	-	-	11000	12700	20800	25100	7070
	303 L2	38.4	36	2040	8.3	9.0	71	80	90	100	112	132	160	-	-	11300	13000	21300	25600	7240
	303 L2	44.6	31	1760	6.2	9.0	71	80	90	100	112	132	160	-	-	11900	13700	22300	26800	7610
	303 L2	55.8	25.1	1770	4.9	9.0	71	80	90	100	112	132	160	-	-	12800	14800	24800	28700	8200
	303 L3	53.4	26.2	1910	5.8	7.5	71	80	90	100	112	132	160	-	-	12600	14500	23500	28300	8080
	303 L3	63.1	22.2	2340	6.0	7.5	71	80	90	100	112	132	160	-	-	13300	15400	24700	29700	8540
	303 L3	72.3	19.4	2020	4.5	7.5	71	80	90	100	112	132	160	-	-	13900	16100	25700	31000	8940
	303 L3	77.2	18.1	2360	4.9	7.5	71	80	90	100	112	132	160	-	-	14200	16400	26300	31600	9140
	303 L3	90.2	15.5	2040	3.6	7.5	71	80	90	100	112	132	160	-	-	15000	17300	27500	33100	9620
	303 L3	105	13.4	2480	3.8	7.5	71	80	90	100	112	132	160	-	-	15800	18200	28800	34600	10100
	303 L3	113	124	1790	2.6	7.5	71	80	90	100	112	132	160	-	-	16200	18600	29400	35400	10400
	303 L3	124	11.2	1800	2.3	7.5	71	80	90	100	112	132	160	-	-	16700	19300	30300	36500	10700
	303 L3	141	9.9	2600	3.0	7.5	71	80	90	100	112	132	160	-	-	17400	20100	31500	37900	11200
	303 L3	152	9.2	1800	1.9	7.5	71	80	90	100	112	132	160	-	-	17900	20600	32200	38700	11500
	303 L3	164	8.6	2200	2.2	7.5	71	80	90	100	112	132	160	-	-	18300	21100	32900	39600	11700
303 L3	178	7.9	2200	2.0	7.5	71	80	90	100	112	132	160	-	-	18800	21700	33700	40600	12100	
303 L3	190	7.4	1800	1.5	7.5	71	80	90	100	112	132	160	-	-	19200	22200	34400	41400	12300	
303 L3	220	6.4	2250	1.6	7.5	71	80	90	100	112	132	160	-	-	20200	23300	36000	43300	13000	
303 L3	258	5.4	1800	1.1	7.5	71	80	90	100	112	132	160	-	-	21300	24600	37700	45300	13600	
303 L3	276	5.1	2200	1.3	7.5	71	80	90	100	112	132	160	-	-	21800	25200	38500	46300	14000	
303 L3	321	4.4	1840	0.92	7.5															

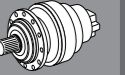
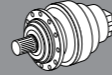

EQ303L							2500 Nm													
n <sub>1</sub> min <sup>-1</sup>	i	n <sub>2</sub> min <sup>-1</sup>	m <sub>n2</sub> Nm	P <sub>n1</sub> kW	Pt kW	P(IEC)	R <sub>n2</sub> [N]													
							MC	MZ	HC/PC	HZ/PZ	FZ									
900	303 L4	1586	1586	2250	0.15	7.2	71	80	90	100	112	132	160	-	-	36000	42000	64000	74000	24000
	303 L4	1854	1854	2300	0.13	7.2	71	80	90	100	112	132	160	-	-	36000	42000	64000	74000	24000
	303 L4	1991	1991	2850	0.15	7.2	71	80	90	100	112	132	160	-	-	36000	42000	64000	74000	24000
	303 L4	2243	2243	2000	0.09	7.2	71	80	90	100	112	132	160	-	-	36000	42000	64000	74000	24000
	303 L4	2799	2799	2000	0.08	7.2	71	80	90	100	112	132	160	-	-	36000	42000	64000	74000	24000

EQ304L							3600 Nm													
n <sub>1</sub> min <sup>-1</sup>	i	n <sub>2</sub> min <sup>-1</sup>	m <sub>n2</sub> Nm	P <sub>n1</sub> kW	Pt kW	P(IEC)	R <sub>n2</sub> [N]													
							MC	MZ	HC/PC	HZ/PZ	FZ									
1400	304 L1	4.25	329	1410	50	12.0	-	-	-	-	-	132	160	180	200	5420	6250	11000	13200	3480
	304 L1	5.33	263	1760	50	12.0	-	-	-	-	-	132	160	180	200	5840	6750	11800	14200	3750
	304 L1	6.57	213	1740	40	12.0	-	-	-	-	-	132	160	180	200	6260	7230	12500	15100	4020
1400	304 L2	12.5	112	2410	30	9.0	71	80	90	100	112	132	160	-	-	7770	8970	15200	18300	4980
	304 L2	15.3	91	2600	26	9.0	71	80	90	100	112	132	160	-	-	8310	9590	16200	19500	5330
	304 L2	18.1	77	2700	23	9.0	71	80	90	100	112	132	160	-	-	8780	10100	17000	20400	5630
	304 L2	20.8	67	2850	21	9.0	71	80	90	100	112	132	160	-	-	9190	10600	17700	21300	5900
	304 L2	22.7	62	2650	18.2	9.0	71	80	90	100	112	132	160	-	-	9470	10900	18200	21900	6080
	304 L2	24.5	57	2950	18.8	9.0	71	80	90	100	112	132	160	-	-	9720	11200	18600	22400	6230
	304 L2	30.8	46	2750	13.9	9.0	71	80	90	100	112	132	160	-	-	10500	12100	19900	24000	6720
	304 L2	38.4	36	2760	11.2	9.0	71	80	90	100	112	132	160	-	-	11300	13000	21300	25600	7240
	304 L2	47.3	29.6	2290	7.5	9.0	71	80	90	100	112	132	160	-	-	12100	14000	22700	27300	7760
	304 L2	59.1	23.7	2290	6.0	9.0	71	80	90	100	112	132	160	-	-	13000	15000	24200	29200	8360
	304 L3	43.6	32	3200	11.8	7.5	71	80	90	100	112	132	160	-	-	11800	13600	22100	26600	7550
	304 L3	53.4	26.2	3240	9.8	7.5	71	80	90	100	112	132	160	-	-	12600	14500	23500	28300	8080
	304 L3	63.1	22.2	3300	8.4	7.5	71	80	90	100	112	132	160	-	-	13300	15400	24700	29700	8540
	304 L3	72.3	19.4	3300	7.3	7.5	71	80	90	100	112	132	160	-	-	13900	16100	25700	31000	8940
	304 L3	77.2	18.1	3360	7.0	7.5	71	80	90	100	112	132	160	-	-	14200	16400	26300	31600	9140
	304 L3	90.2	15.5	3260	5.8	7.5	71	80	90	100	112	132	160	-	-	15000	17300	27500	33100	9620
	304 L3	105	13.4	3450	5.3	7.5	71	80	90	100	112	132	160	-	-	15800	18200	28800	34600	10100
	304 L3	111	12.7	3390	4.9	7.5	71	80	90	100	112	132	160	-	-	16000	18500	29200	35200	10300
	304 L3	130	10.7	3520	4.3	7.5	71	80	90	100	112	132	160	-	-	17000	19600	30700	37000	10900
	304 L3	141	9.9	3540	4.0	7.5	71	80	90	100	112	132	160	-	-	17400	20100	31500	37900	11200
	304 L3	150	9.4	3450	3.7	7.5	71	80	90	100	112	132	160	-	-	17800	20500	32000	38500	11400
	304 L3	165	8.5	2290	2.2	7.5	71	80	90	100	112	132	160	-	-	18300	21200	33000	39600	11800
	304 L3	178	7.9	2800	2.5	7.5	71	80	90	100	112	132	160	-	-	18800	21700	33700	40600	12100
	304 L3	202	6.9	2290	1.8	7.5	71	80	90	100	112	132	160	-	-	19600	22600	35000	42100	12600
	304 L3	220	6.4	3610	2.6	7.5	71	80	90	100	112	132	160	-	-	20200	23300	36000	43300	13000
	304 L3	273	5.1	2290	1.3	7.5	71	80	90	100	112	132	160	-	-	21700	25000	38300	46100	13900
	304 L3	341	4.1	2320	1.1	7.5	71	80	90	100	112	132	160	-	-	23400	27000	41000	49300	15000
	304 L3	426	3.3	2360	0.89	7.5	71	80	90	100	112	132	160	-	-	25200	29000	43800	52700	16100
	304 L4	413	3.4	2950	1.2	6.0	71	80	90	100	112	132	160	-	-	24900	28800	43400	52200	16000
	304 L4	446	3.1	3690	1.4	6.0	71	80	90	100	112	132	160	-	-	25500	29500	44400	53400	16400
	304 L4	492	2.8	3700	1.2	6.0	71	80	90	100	112	132	160	-	-	26400	30500	45800	55100	16900
	304 L4	556	2.5	3710	1.1	6.0	71	80	90	100	112	132	160	-	-	27500	31700	47500	57100	17600
	304 L4	649	2.2	3550	0.91	6.0	71	80	90	100	112	132	160	-	-	29000	33400	49700	59800	18600
	304 L4	702	2.0	2480	0.59	6.0	71	80	90	100	112	132	160	-	-	29700	34300	50900	61300	19100
	304 L4	816	1.7	3810	0.77	6.0	71	80	90	100	112	132	160	-	-	31300	36100	53300	64100	20000
304 L4	1018	1.4	3870	0.63	6.0	71	80	90	100	112	132	160	-	-	33600	38800	56900	68500	21600	
304 L4	1164	1.2	2680	0.38	6.0	71	80	90	100	112	132	160	-	-	35200	40600	59200	71300	22600	
304 L4	1271	1.1	3930	0.51	6.0	71	80	90	100	112	132	160	-	-	36000	41800	60800	73200	23200	
304 L4	1344	1.0	3700	0.46	6.0	71	80	90	100	112	132	160	-	-	36000	42000	61900	74000	23700	
304 L4	1586	0.88	3960	0.41	6.0	71	80	90	100	112	132	160	-	-	36000	42000	64000	74000	24000	
304 L4	1815	0.77	2750	0.25	6.0	71	80	90	100	112	132	160	-	-	36000	42000	64000	74000	24000	
304 L4	1991	0.70	3500	0.29	6.0	71	80	90	100	112	132	160	-	-	36000	42000	64000	74000	24000	
304 L4	2269	0.62	2750	0.20	6.0	71	80	90	100	112	132	160	-	-	36000	42000	64000	74000	24000	
304 L4	2453	0.57	2750	0.19	6.0	71	80	90	100	112	132	160	-	-	36000	42000	64000	74000	24000	

EQ304L							3600 Nm													
n <sub>1</sub> min <sup>-1</sup>	i	n <sub>2</sub> min <sup>-1</sup>	m <sub>n2</sub> Nm	P <sub>n1</sub> kW	Pt kW	P(IEC)	R <sub>n2</sub> [N]													
							MC	MZ	HC/PC	HZ/PZ	FZ									
900	304 L1	3.60	250	1850	50	14.4	-	-	-	-	-	132	160	180	200	5940	6860	12000	14400	3810
	304 L1	4.25	212	2000	46	14.4	-	-	-	-	-	132	160	180	200	6280	7250	12600	15100	4030
	304 L1	5.33	169	2080	38	14.4	-	-	-	-	-	132	160	180	200	6770	7820	13400	16200	4340
	304 L1	6.57	137	1980	29	14.4	-	-	-	-	-	132	160	180	200	7260	8380	14300	17200	4660
	304 L2	12.5	72	2800	22	10.8	71	80	90	100	112	132	160	-	-	9000	10400	17400	20900	5770
	304 L2	15.3	59	2970	19.4	10.8	71	80	90	100	112	132	160	-	-	9630	11100	18500	22200	6180
	304 L2	18.1	50	3070	17.0	10.8	71	80	90	100	112	132	160	-	-	10200				

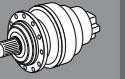
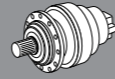

EQ305L 5000 Nm table with columns for n1, i, n2, mn2, Pn1, Pt, P(IEC), Rn2 [N] (MC, MZ, HC/PC, HZ/PZ, FZ)

EQ305L 5000 Nm table with columns for n1, i, n2, mn2, Pn1, Pt, P(IEC), Rn2 [N] (MC, MZ, HC/PC, HZ/PZ, FZ)

EQ306L 8500 Nm table with columns for n1, i, n2, mn2, Pn1, Pt, P(IEC), Rn2 [N] (MC, MZ, HC/PC, HZ/PZ, FZ)

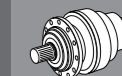
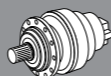

EQ306L										8500 Nm														
n <sub>1</sub> min <sup>-1</sup>		i	n <sub>2</sub> min <sup>-1</sup>	m <sub>n2</sub> Nm	P <sub>n1</sub> kW	Pt kW	P(IEC)	R <sub>n2</sub> [N]																
								MC	MZ	HC/PC	HZ/PZ	FZ												
1400	306 L3	53.2	26.3	5880	17.7	7.5	-	71	80	90	100	112	132	160	-	-	-	-	-	15700	17800	38400	44700	11800
	306 L3	65.2	21.5	6070	14.9	7.5	-	71	80	90	100	112	132	160	-	-	-	-	-	16800	19000	40800	47500	12600
	306 L3	77.0	18.2	7290	15.2	7.5	-	71	80	90	100	112	132	160	-	-	-	-	-	17700	20100	42900	50000	13300
	306 L3	81.9	17.1	6550	12.9	7.5	-	71	80	90	100	112	132	160	-	-	-	-	-	18100	20500	43700	50900	13600
	306 L3	88.3	15.9	6440	11.7	7.5	-	71	80	90	100	112	132	160	-	-	-	-	-	18500	21000	44700	52100	13900
	306 L3	104	13.4	7590	11.7	7.5	-	71	80	90	100	112	132	160	-	-	-	-	-	19600	22200	47000	54700	14700
	306 L3	112	12.5	6930	9.9	7.5	-	71	80	90	100	112	132	160	-	-	-	-	-	20100	22800	48100	56000	15100
	306 L3	121	11.5	7580	10.0	7.5	-	71	80	90	100	112	132	160	-	-	-	-	-	20600	23400	49200	57300	15500
	306 L3	141	9.9	7800	8.9	7.5	-	71	80	90	100	112	132	160	-	-	-	-	-	21700	24600	51500	59900	16300
	306 L3	152	9.2	7400	7.8	7.5	-	71	80	90	100	112	132	160	-	-	-	-	-	22200	25200	52600	61300	16700
	306 L3	190	7.4	6500	5.5	7.5	-	71	80	90	100	112	132	160	-	-	-	-	-	23900	27100	56200	65500	18000
	306 L3	205	6.8	7800	6.1	7.5	-	71	80	90	100	112	132	160	-	-	-	-	-	24500	27800	57600	67000	18400
	306 L3	222	6.3	6500	4.7	7.5	-	71	80	90	100	112	132	160	-	-	-	-	-	25200	28600	58900	68600	18900
	306 L3	238	5.9	7800	5.3	7.5	-	71	80	90	100	112	132	160	-	-	-	-	-	25800	29200	60200	70100	19400
	306 L3	268	5.2	5500	3.3	7.5	-	71	80	90	100	112	132	160	-	-	-	-	-	26900	30400	62400	72700	20200
	306 L3	288	4.9	5520	3.1	7.5	-	71	80	90	100	112	132	160	-	-	-	-	-	27500	31200	63700	74200	20700
	306 L3	325	4.3	5580	2.8	7.5	-	71	80	90	100	112	132	160	-	-	-	-	-	28600	32400	66100	76900	21500
	306 L3	405	3.5	5710	2.3	7.5	-	71	80	90	100	112	132	160	-	-	-	-	-	30800	34900	70600	82200	23100
	306 L4	3.6	3.6	6830	2.9	6.0	-	71	80	90	100	112	132	160	-	-	-	-	-	30400	34500	69900	81400	22900
	306 L4	3.2	3.2	9530	3.6	6.0	-	71	80	90	100	112	132	160	-	-	-	-	-	31800	36000	72600	84500	23900
	306 L4	2.7	2.7	8700	2.8	6.0	-	71	80	90	100	112	132	160	-	-	-	-	-	33300	37700	75600	88100	25000
	306 L4	2.4	2.4	8550	2.4	6.0	-	71	80	90	100	112	132	160	-	-	-	-	-	34900	39600	79000	92000	26200
	306 L4	2.2	2.2	8730	2.3	6.0	-	71	80	90	100	112	132	160	-	-	-	-	-	35800	40600	80800	94100	26900
	306 L4	2.0	2.0	8730	2.1	6.0	-	71	80	90	100	112	132	160	-	-	-	-	-	37000	41900	83200	96900	27800
306 L4	1.7	1.7	7440	1.5	6.0	-	71	80	90	100	112	132	160	-	-	-	-	-	38800	44000	86900	101200	29200	
306 L4	1.6	1.6	7450	1.4	6.0	-	71	80	90	100	112	132	160	-	-	-	-	-	39900	45200	89000	103700	29900	
306 L4	1.4	1.4	9010	1.5	6.0	-	71	80	90	100	112	132	160	-	-	-	-	-	41900	47400	93000	108300	31400	
306 L4	1.3	1.3	7470	1.1	6.0	-	71	80	90	100	112	132	160	-	-	-	-	-	42900	48600	95200	110800	32200	
306 L4	1.1	1.1	8360	1.1	6.0	-	71	80	90	100	112	132	160	-	-	-	-	-	45000	51000	99700	116100	34000	
306 L4	0.95	0.95	9500	1.1	6.0	-	71	80	90	100	112	132	160	-	-	-	-	-	45000	51000	101000	119000	35000	
306 L4	0.88	0.88	8500	0.88	6.0	-	71	80	90	100	112	132	160	-	-	-	-	-	45000	51000	101000	119000	35000	
306 L4	0.76	0.76	9500	0.85	6.0	-	71	80	90	100	112	132	160	-	-	-	-	-	45000	51000	101000	119000	35000	
306 L4	0.68	0.68	7000	0.56	6.0	-	71	80	90	100	112	132	160	-	-	-	-	-	45000	51000	101000	119000	35000	
306 L4	0.60	0.60	7000	0.50	6.0	-	71	80	90	100	112	132	160	-	-	-	-	-	45000	51000	101000	119000	35000	
306 L4	0.48	0.48	7000	0.40	6.0	-	71	80	90	100	112	132	160	-	-	-	-	-	45000	51000	101000	119000	35000	
900	306 L1	3.60	250	2780	75	22	-	-	-	-	-	-	-	-	-	-	-	-	7400	8380	19500	22800	5560	
	306 L1	4.25	212	3280	75	22	-	-	-	-	-	-	-	-	-	-	-	-	7820	8860	20500	23900	5870	
	306 L1	5.33	169	3930	72	22	-	-	-	-	-	-	-	-	-	-	-	-	8430	9550	22000	25600	6330	
	306 L1	6.20	145	4160	65	22	-	-	-	-	-	-	-	-	-	-	-	-	-	8860	10000	23000	26800	6660
	306 L1	7.50	120	3650	47	22	-	-	-	-	-	-	-	-	-	-	-	-	-	9440	10700	24400	28400	7100
	306 L2	13.0	69	4630	36	15.6	-	-	-	-	-	-	-	-	-	-	-	-	-	11300	12800	28700	33400	8520
	306 L2	15.3	59	4860	32	15.6	-	-	-	-	-	-	-	-	-	-	-	-	-	12000	13600	30200	35100	9000
	306 L2	18.1	50	5810	32	15.6	-	-	-	-	-	-	-	-	-	-	-	-	-	12700	14300	31700	36900	9510
	306 L2	22.7	40	6100	27	15.6	-	-	-	-	-	-	-	-	-	-	-	-	-	13700	15500	34000	39500	10300
	306 L2	26.4	34	5190	19.7	15.6	-	-	-	-	-	-	-	-	-	-	-	-	-	14400	16300	35500	41400	10800
	306 L2	28.4	32	6230	22	15.6	-	-	-	-	-	-	-	-	-	-	-	-	-	14700	16700	36300	42300	11100
	306 L2	33.1	27.2	6200	18.8	15.6	-	-	-	-	-	-	-	-	-	-	-	-	-	15500	17500	38000	44300	11600
	306 L2	38.4	23.4	6090	15.9	15.6	-	-	-	-	-	-	-	-	-	-	-	-	-	16300	18500	39800	46300	12200
	306 L2	46.5	19.4	6180	13.3	15.6	-	-	-	-	-	-	-	-	-	-	-	-	-	17400	19700	42100	49000	13000
	306 L2	56.3	16.0	5250	9.4	15.6	-	-	-	-	-	-	-	-	-	-	-	-	-	18500	20900	44600	51900	13900
	306 L2	72.5	12.4	5390	7.4	15.6	-	-	-	-	-	-	-	-	-	-	-	-	-	20100	22800	48100	56000	15100
	306 L3	53.2	16.9	6570	12.7	9.0	-	-	-	-	-	-	-	-	-	-	-	-	-	18200	20600	43900	51100	13600
	306 L3	65.2	13.8	6860	10.9	9.0	-	-	-	-	-	-	-	-	-	-	-	-	-	19400	22000	46600	54300	14600
	306 L3	77.0	11.7	8310	11.1	9.0	-	-	-	-	-	-	-	-	-	-	-	-	-	20500	23300	49000	57100	15400
	306 L3	81.9	11.0	7320	9.2	9.0	-	-	-	-	-	-	-	-	-	-	-	-	-	21000	23700	49900	58100	15700
	306 L3	88.3	10.2	7360	8.6	9.0	-	-	-	-	-	-	-	-	-	-	-	-	-	21500	24300	51000	59400	16100
	306 L3	104	8.6	8520	8.4	9.0	-	-</																

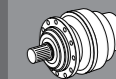
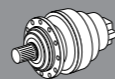

EQ307L										12500 Nm														
n <sub>1</sub> min <sup>-1</sup>	i	n <sub>2</sub> min <sup>-1</sup>	m <sub>n2</sub> Nm	P <sub>n1</sub> kW	Pt kW	P(IEC)					R <sub>n2</sub> [N]													
						MC	MZ	HC/PC	HZ/PZ	FZ	MC	MZ	HC/PC	HZ/PZ	FZ									
1400	307 L4	349	4.0	13200	6.3	7.5	71	80	90	100	112	132	160	—	—	—	—	—	—	32600	40900	72700	95200	28300
	307 L4	405	3.5	11400	4.6	7.5	71	80	90	100	112	132	160	—	—	—	—	—	—	34300	43000	76000	99600	29800
	307 L4	465	3.0	11600	4.1	7.5	71	80	90	100	112	132	160	—	—	—	—	—	—	35800	45000	79200	103700	31200
	307 L4	509	2.7	13700	4.4	7.5	71	80	90	100	112	132	160	—	—	—	—	—	—	37000	46400	81400	106600	32100
	307 L4	579	2.4	13800	4.0	7.5	71	80	90	100	112	132	160	—	—	—	—	—	—	38600	48400	84500	110800	33500
	307 L4	654	2.1	12300	3.1	7.5	71	80	90	100	112	132	160	—	—	—	—	—	—	40200	50400	87700	114900	34900
	307 L4	722	1.9	14100	3.2	7.5	71	80	90	100	112	132	160	—	—	—	—	—	—	41500	52100	90400	118400	36100
	307 L4	801	1.7	12700	2.6	7.5	71	80	90	100	112	132	160	—	—	—	—	—	—	43000	53900	93200	122100	37400
	307 L4	906	1.5	14400	2.6	7.5	71	80	90	100	112	132	160	—	—	—	—	—	—	44800	56200	96700	126800	38900
	307 L4	999	1.4	13200	2.2	7.5	71	80	90	100	112	132	160	—	—	—	—	—	—	46300	58000	99600	130500	40200
	307 L4	1157	1.2	13600	1.9	7.5	71	80	90	100	112	132	160	—	—	—	—	—	—	48600	60900	104100	136400	42200
	307 L4	1274	1.1	12300	1.6	7.5	71	80	90	100	112	132	160	—	—	—	—	—	—	50200	63000	107100	140400	43600
	307 L4	1408	0.99	15000	1.8	7.5	71	80	90	100	112	132	160	—	—	—	—	—	—	51900	65000	109000	144700	45000
	307 L4	1591	0.88	15000	1.6	7.5	71	80	90	100	112	132	160	—	—	—	—	—	—	52000	65000	109000	145000	45000
	307 L4	1767	0.79	15000	1.4	7.5	71	80	90	100	112	132	160	—	—	—	—	—	—	52000	65000	109000	145000	45000
	307 L4	2041	0.69	14000	1.1	7.5	71	80	90	100	112	132	160	—	—	—	—	—	—	52000	65000	109000	145000	45000
	307 L4	2423	0.58	11000	0.75	7.5	71	80	90	100	112	132	160	—	—	—	—	—	—	52000	65000	109000	145000	45000
900	307 L1	3.43	263	4060	115	26	—	—	—	—	—	—	—	180	200	225	250	—	—	8090	10100	20700	27200	7030
	307 L1	4.09	220	4840	115	26	—	—	—	—	—	—	—	180	200	225	250	—	—	8580	10800	21900	28600	7450
	307 L1	5.25	171	5270	98	26	—	—	—	—	—	—	—	180	200	225	250	—	—	9320	11700	23500	30900	8100
	307 L1	6.23	144	5550	87	26	—	—	—	—	—	—	—	180	200	225	250	—	—	9870	12400	24800	32500	8580
	307 L2	12.3	73	7150	58	22	—	—	—	—	—	—	132	160	180	200	—	—	—	12400	15500	30400	39900	10800
	307 L2	14.7	61	7430	51	22	—	—	—	—	—	—	132	160	180	200	—	—	—	13100	16500	32100	42100	11400
	307 L2	17.4	52	7820	45	22	—	—	—	—	—	—	132	160	180	200	—	—	—	13900	17400	33700	44200	12100
	307 L2	21.8	41	8350	38	22	—	—	—	—	—	—	132	160	180	200	—	—	—	15000	18800	36100	47300	13000
	307 L2	25.4	36	8710	34	22	—	—	—	—	—	—	132	160	180	200	—	—	—	15800	19800	37800	49500	13700
	307 L2	28.0	32	8380	30	22	—	—	—	—	—	—	132	160	180	200	—	—	—	16300	20400	38900	51000	14200
	307 L2	30.7	29.3	9070	30	22	—	—	—	—	—	—	132	160	180	200	—	—	—	16800	21100	40000	52400	14600
	307 L2	32.6	27.6	8630	27	22	—	—	—	—	—	—	132	160	180	200	—	—	—	17100	21500	40700	53300	14900
	307 L2	38.6	23.3	8160	21	22	—	—	—	—	—	—	132	160	180	200	—	—	—	18100	22700	42900	56200	15800
	307 L2	46.7	19.3	8280	17.7	22	—	—	—	—	—	—	132	160	180	200	—	—	—	19300	24200	45400	59500	16800
	307 L3	51.3	17.6	10600	21	13.2	71	80	90	100	112	132	160	—	—	—	—	—	—	19900	25000	46600	61100	17300
	307 L3	60.5	14.9	11200	19.0	13.2	71	80	90	100	112	132	160	—	—	—	—	—	—	21100	26400	49000	64300	18300
	307 L3	74.1	12.1	11800	16.5	13.2	71	80	90	100	112	132	160	—	—	—	—	—	—	22500	28300	52100	68300	19600
	307 L3	80.6	11.2	10300	13.2	13.2	71	80	90	100	112	132	160	—	—	—	—	—	—	23200	29100	53400	70000	20100
	307 L3	93.0	9.7	12500	13.9	13.2	71	80	90	100	112	132	160	—	—	—	—	—	—	24300	30500	55800	73100	21100
	307 L3	100	9.0	12600	12.9	13.2	71	80	90	100	112	132	160	—	—	—	—	—	—	24900	31300	57100	74800	21700
	307 L3	113	7.9	10600	9.6	13.2	71	80	90	100	112	132	160	—	—	—	—	—	—	25900	32600	59200	77500	22600
	307 L3	126	7.1	12700	10.4	13.2	71	80	90	100	112	132	160	—	—	—	—	—	—	26900	33700	61100	80000	23400
	307 L3	139	6.5	10600	7.9	13.2	71	80	90	100	112	132	160	—	—	—	—	—	—	27800	34800	62900	82400	24100
	307 L3	146	6.2	12800	9.0	13.2	71	80	90	100	112	132	160	—	—	—	—	—	—	28300	35500	63900	83700	24600
	307 L3	162	5.6	10700	6.8	13.2	71	80	90	100	112	132	160	—	—	—	—	—	—	29200	36600	65800	86300	25400
	307 L3	177	5.1	12300	7.2	13.2	71	80	90	100	112	132	160	—	—	—	—	—	—	30100	37800	67700	88700	26200
	307 L3	202	4.5	10900	5.6	13.2	71	80	90	100	112	132	160	—	—	—	—	—	—	31400	39400	70400	92200	27300
	307 L3	221	4.1	13200	6.2	13.2	71	80	90	100	112	132	160	—	—	—	—	—	—	32400	40700	72300	94800	28200
	307 L3	239	3.8	9060	3.9	13.2	71	80	90	100	112	132	160	—	—	—	—	—	—	33300	41800	74100	97100	28900
	307 L3	284	3.2	11500	4.2	13.2	71	80	90	100	112	132	160	—	—	—	—	—	—	35200	44200	77900	102100	30600
	307 L3	336	2.7	9510	2.9	13.2	71	80	90	100	112	132	160	—	—	—	—	—	—	37300	46800	82000	107500	32400
	307 L4	349	2.6	13800	4.2	9.0	71	80	90	100	112	132	160	—	—	—	—	—	—	37800	47400	82900	108700	32800
	307 L4	406	2.2	12200	3.2	9.0	71	80	90	100	112	132	160	—	—	—	—	—	—	39700	49800	86800	113700	34500
	307 L4	465	1.9	12500	2.9	9.0	71	80	90	100	112	132	160	—	—	—	—	—	—	41500	52100	90400	118400	36100
	307 L4	509	1.8	14200	3.0	9.0	71	80	90	100	112	132	160	—	—	—	—	—	—	42800	53700	92900	121700	37200
	307 L4	579	1.6	14400	2.7	9.0	71	80	90	100	112	132	160	—	—	—	—	—	—	44700	56100	96500	126500	38800
	307 L4	654	1.4	13300	2.2	9.0	71	80	90	100	112	132	160	—	—	—	—	—	—	46500	58400	100100	131200	40400
	307 L4	722	1.2	14700	2.2	9.0	71	80	90	100	112	132	160	—	—	—	—	—	—	48100	60400	103200	135200	41800
	307 L4	801	1.1	13700	1.8	9.0	71	80	90	100	112	132	160	—	—	—	—	—	—	49800	62500	106400	139400	43300
	307 L4	906	0.99	15000	1.8	9.0	71	80	90	100	112	132	160	—	—	—	—	—	—	51900	65000	109000	144700	45000
	307 L4	999	0.90	14000	1.5	9.0	71	80	90	100	112	132	160	—	—	—	—	—	—	52000	65000	109000	145000	45000
	307 L4	1157	0.78	14000	1.3	9.0	71	80	90	100	112	132	160	—	—	—	—	—	—	52000	650			

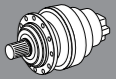
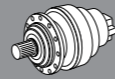
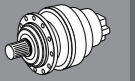
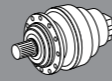

Table for EQ309L gearbox with 18000 Nm output. Columns include input speed (n1), gear ratio (i), output speed (n2), torque (m\_n2), power (P\_n1, P\_t), and load capacity (R\_n2) for various mounting options (MC, MZ, HC/PC, HZ/PZ, FZ).

Table for EQ310L gearbox with 25000 Nm output. Columns include input speed (n1), gear ratio (i), output speed (n2), torque (m\_n2), power (P\_n1, P\_t), and load capacity (R\_n2) for various mounting options (MC, MZ, HC/PC, HZ/PZ, FZ).

Table for EQ310L gearbox with 25000 Nm output. Columns include input speed (n1), gear ratio (i), output speed (n2), torque (m\_n2), power (P\_n1, P\_t), and load capacity (R\_n2) for various mounting options (MC, MZ, HC/PC, HZ/PZ, FZ).

Table for EQ310L gearbox with 25000 Nm output. Columns include input speed (n1), gear ratio (i), output speed (n2), torque (m\_n2), power (P\_n1, P\_t), and load capacity (R\_n2) for various mounting options (MC, MZ, HC/PC, HZ/PZ, FZ).



EQ311L						40000 Nm												
n <sub>1</sub> min <sup>-1</sup>		i	n <sub>2</sub> min <sup>-1</sup>	m <sub>n2</sub> Nm	P <sub>n1</sub> kW	Pt kW	P(IEC)	R <sub>n2</sub> [N]										
								MC	MZ	HC/PC	HZ/PZ	FZ						
1400	311 L1	4.09	342	5410	200	35	-	-	-	27200	33900	9290						
	311 L1	5.25	267	6950	200	35	-	-	-	29300	36600	10100						
	311 L1	6.23	225	8250	200	35	-	-	-	30900	38500	10700						
	311 L2	14.0	100	10400	115	26	-	-	-	39400	49100	14000						
	311 L2	16.7	84	12400	115	26	-	-	-	41600	51800	14900						
	311 L2	18.0	78	13300	115	26	-	-	-	42500	52900	15200						
	311 L2	21.5	65	15900	115	26	-	-	-	44800	55800	16200						
	311 L2	25.5	55	18200	111	26	-	-	-	47100	58700	17100						
	311 L2	27.6	51	19600	111	26	-	-	-	48300	60100	17600						
	311 L2	32.7	43	20600	98	26	-	-	-	50800	63300	18600						
	311 L2	38.8	36	20100	81	26	-	-	-	53500	66600	19700						
	311 L3	50.5	27.7	18900	60	18.0	-	-	-	57900	72100	21500						
	311 L3	60.2	23.2	22500	60	18.0	-	-	-	61000	76000	22800						
	311 L3	71.1	19.7	24700	56	18.0	-	-	-	64100	79900	24100						
	311 L3	77.3	18.1	25400	53	18.0	-	-	-	65800	81900	24800						
	311 L3	89.3	15.7	26500	48	18.0	-	-	-	68100	84900	25700						
	311 L3	104	13.5	27700	43	18.0	-	-	-	71800	89500	27300						
	311 L3	115	12.2	28500	40	18.0	-	-	-	74000	92200	28200						
	311 L3	126	11.2	29300	38	18.0	-	-	-	76100	94700	29100						
	311 L3	133	10.5	29800	36	18.0	-	-	-	77400	96400	29700						
	311 L3	147	9.5	32000	35	18.0	-	-	-	79700	99300	30700						
	311 L3	161	8.7	31600	32	18.0	-	-	-	82000	102100	31600						
	311 L3	171	8.2	32100	30	18.0	-	-	-	83400	103900	32200						
	311 L3	191	7.3	32100	27	18.0	-	-	-	86300	107500	33500						
	311 L3	203	6.9	32200	25	18.0	-	-	-	87800	109400	34100						
	311 L3	245	5.7	32200	21	18.0	-	-	-	93000	115800	36400						
	311 L3	291	4.8	27100	15.0	18.0	-	-	-	97900	121900	38500						
	311 L4	348	4.0	39600	18.9	11.0	71	80	90	100	112	132	160	-	-	103200	128600	40900
	311 L4	410	3.4	41400	16.7	11.0	71	80	90	100	112	132	160	-	-	108500	135200	43200
	311 L4	512	2.7	43900	14.2	11.0	71	80	90	100	112	132	160	-	-	116000	144500	46500
	311 L4	568	2.5	41700	12.2	11.0	71	80	90	100	112	132	160	-	-	119600	149000	48100
	311 L4	627	2.2	37200	9.8	11.0	71	80	90	100	112	132	160	-	-	123200	153500	49700
	311 L4	724	1.9	45000	10.3	11.0	71	80	90	100	112	132	160	-	-	128700	160300	52200
	311 L4	825	1.7	42700	8.6	11.0	71	80	90	100	112	132	160	-	-	133800	166600	54500
	311 L4	904	1.5	45000	8.2	11.0	71	80	90	100	112	132	160	-	-	137500	171300	56200
	311 L4	986	1.4	40400	6.8	11.0	71	80	90	100	112	132	160	-	-	141100	175800	57800
	311 L4	1058	1.3	40900	6.4	11.0	71	80	90	100	112	132	160	-	-	144200	179600	59200
	311 L4	1230	1.1	42000	5.7	11.0	71	80	90	100	112	132	160	-	-	150800	187900	62300
	311 L4	1415	0.99	43000	5.0	11.0	71	80	90	100	112	132	160	-	-	157000	195000	65000
	311 L4	1680	0.83	34000	3.4	11.0	71	80	90	100	112	132	160	-	-	157000	195000	65000
	311 L4	1766	0.79	43000	4.0	11.0	71	80	90	100	112	132	160	-	-	157000	195000	65000
	311 L4	2096	0.67	34000	2.7	11.0	71	80	90	100	112	132	160	-	-	157000	195000	65000
900	311 L1	4.09	220	8420	200	42	-	-	-	31100	38700	10800						
	311 L1	5.25	171	10800	200	42	-	-	-	33500	41700	11700						
	311 L1	6.23	144	12800	200	42	-	-	-	35300	43900	12400						
	311 L2	14.0	64	16100	115	31	-	-	-	45000	56000	16200						
	311 L2	16.7	54	18300	110	31	-	-	-	47400	59100	17200						
	311 L2	18.0	50	19700	110	31	-	-	-	48500	60400	17600						
	311 L2	21.5	42	19700	92	31	-	-	-	51100	63700	18700						
	311 L2	25.5	35	20800	82	31	-	-	-	53800	67000	19800						
	311 L2	27.6	33	22400	81	31	-	-	-	55100	68600	20300						
	311 L2	32.7	27.5	23600	72	31	-	-	-	58000	72300	21500						
	311 L2	38.8	23.2	22200	57	31	-	-	-	61100	76100	22800						
	311 L3	50.5	17.8	25500	52	22	-	-	-	66100	82300	24900						
	311 L3	60.2	14.9	26900	46	22	-	-	-	69700	86800	26400						
	311 L3	71.1	12.7	28200	41	22	-	-	-	73200	91200	27900						
	311 L3	77.3	11.6	29000	39	22	-	-	-	75100	93500	28700						
	311 L3	87.0	10.3	30000	36	22	-	-	-	77800	96900	29800						
	311 L3	104	8.7	31600	31	22	-	-	-	82000	102200	31600						
	311 L3	115	7.9	32600	29	22	-	-	-	84500	105200	32700						
	311 L3	126	7.2	33500	28	22	-	-	-	86800	108200	33700						
	311 L3	133	6.8	34100	26	22	-	-	-	88400	110100	34400						

EQ311L						40000 Nm												
n <sub>1</sub> min <sup>-1</sup>		i	n <sub>2</sub> min <sup>-1</sup>	m <sub>n2</sub> Nm	P <sub>n1</sub> kW	Pt kW	P(IEC)	R <sub>n2</sub> [N]										
								MC	MZ	HC/PC	HZ/PZ	FZ						
900	311 L3	147	6.1	32200	23	22	-	-	-	91000	113400	35500						
	311 L3	161	5.6	36200	23	22	-	-	-	93600	116600	36600						
	311 L3	171	5.3	32300	19.5	22	-	-	-	95300	118700	37400						
	311 L3	191	4.7	34500	18.6	22	-	-	-	98500	122700	38800						
	311 L3	203	4.4	33000	16.8	22	-	-	-	100300	124900	39600						
	311 L3	245	3.7	34100	14.4	22	-	-	-	106200	132300	42100						
	311 L3	291	3.1	28700	10.2	22	-	-	-	111800	139200	44600						
	311 L4	348	2.6	44600	13.7	13.2	71	80	90	100	112	132	160	-	-	117900	146800	47300
	311 L4	410	2.2	45000	11.7	13.2	71	80	90	100	112	132	160	-	-	123900	154300	50000
	311 L4	512	1.8	45000	9.4	13.2	71	80	90	100	112	132	160	-	-	132400	164900	53900
	311 L4	568	1.6	42900	8.0	13.2	71	80	90	100	112	132	160	-	-	136600	170100	55700
	311 L4	627	1.4	40300	6.8	13.2	71	80	90	100	112	132	160	-	-	140700	175200	57600
	311 L4	724	1.2	45000	6.6	13.2	71	80	90	100	112	132	160	-	-	146900	183000	60500
	311 L4	825	1.1	43900	5.7	13.2	71	80	90	100	112	132	160	-	-	152700	190300	63100
	311 L4	904	1.00	45000	5.3	13.2	71	80	90	100	112	132	160	-	-	157000	195000	65000
	311 L4	986	0.91	43000	4.6	13.2	71	80	90	100	112	132	160	-	-	157000	195000	65000
	311 L4	1058	0.85	43000	4.3	13.2	71	80	90	100	112	132	160	-	-	157000	195000	65000
	311 L4	1230	0.73	43000	3.7	13.2	71	80	90	100	112	132	160	-	-	157000	195000	65000
	311 L4	1415	0.64	43000	3.2	13.2	71	80	90	100	112	132	160	-	-	157000	195000	65000
	311 L4	1680	0.54	34000	2.2	13.2	71	80	90	100	112	132	160	-	-	157000	195000	65000
	311 L4	1766	0.51	43000	2.6	13.2	71	80	90	100	112	132	160	-	-	157000	195000	65000
	311 L4	2096	0.43	34000	1.7	13.2	71	80	90	100	112	132	160	-	-	157000	195000	65000

EQ313L						55000 Nm						
n <sub>1</sub> min <sup>-1</sup>		i	n <sub>2</sub> min <sup>-1</sup>	m <sub>n2</sub> Nm	P <sub>n1</sub> kW	Pt kW	P(IEC)	R <sub>n2</sub> [N]				
								MC	MZ	HC/PC	HZ/PZ	FZ
1400	313 L2	14.2	99	13700	150	30	-	-	-	48900	57800	17300
	313 L2	16.9	83	16300	150	30	-	-	-	51500	61000	18400
	313 L2	18.5	76	17800	150	30	-	-	-	52900	62600	18900
	313 L2	21.8	64	20900	150	30	-	-	-	55500	65700	20000
	313 L2	25.8	54	24900	150	30	-	-	-	58500	69200	21100
	313 L2	28.4	49	27300	150	30	-	-	-	60100	71200	21800
	313 L2	33.6	42	29400	136	30	-	-	-	63300	74900	23100

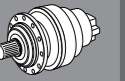
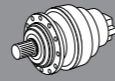

EQ313L										55000 Nm											
n <sub>1</sub> min <sup>-1</sup>	i	n <sub>2</sub> min <sup>-1</sup>	m <sub>n2</sub> Nm	P <sub>n1</sub> kW	Pt kW	P(IEC)										R <sub>n2</sub> [N]					
						MC	MZ	HC/PC	HZ/PZ	FZ	MC	MZ	HC/PC	HZ/PZ	FZ						
1400	313 L4	352	4.0	45100	21	11.0	71	80	90	100	112	132	160	-	-	-	-	-	128000	151500	50500
	313 L4	394	3.6	55000	23	11.0	71	80	90	100	112	132	160	-	-	-	-	-	132500	156800	52400
	313 L4	452	3.1	53400	19.6	11.0	71	80	90	100	112	132	160	-	-	-	-	-	138000	163300	54900
	313 L4	514	2.7	47800	15.4	11.0	71	80	90	100	112	132	160	-	-	-	-	-	143400	169700	57300
	313 L4	564	2.5	55000	16.2	11.0	71	80	90	100	112	132	160	-	-	-	-	-	147500	174500	59100
	313 L4	633	2.2	52100	13.6	11.0	71	80	90	100	112	132	160	-	-	-	-	-	152700	180700	61400
	313 L4	695	2.0	49700	11.8	11.0	71	80	90	100	112	132	160	-	-	-	-	-	157000	185900	63300
	313 L4	790	1.8	52300	11.0	11.0	71	80	90	100	112	132	160	-	-	-	-	-	163200	193100	66100
	313 L4	889	1.6	51500	9.6	11.0	71	80	90	100	112	132	160	-	-	-	-	-	169100	200100	68800
	313 L4	1014	1.4	52500	8.6	11.0	71	80	90	100	112	132	160	-	-	-	-	-	175900	208200	71800
	313 L4	1117	1.3	52600	7.8	11.0	71	80	90	100	112	132	160	-	-	-	-	-	181100	214300	74200
	313 L4	1266	1.1	54200	7.1	11.0	71	80	90	100	112	132	160	-	-	-	-	-	188000	222500	77400
	313 L4	1394	1.0	52800	6.3	11.0	71	80	90	100	112	132	160	-	-	-	-	-	192000	229000	79900
	313 L4	1502	0.93	55000	6.1	11.0	71	80	90	100	112	132	160	-	-	-	-	-	192000	231000	80000
	313 L4	1817	0.77	55000	5.0	11.0	71	80	90	100	112	132	160	-	-	-	-	-	192000	231000	80000
	313 L4	2187	0.64	49000	3.7	11.0	71	80	90	100	112	132	160	-	-	-	-	-	192000	231000	80000
900	313 L1	4.14	217	10700	250	45	-	-	-	-	-	-	-	-	-	-	-	-	38600	45600	13300
	313 L1	5.40	167	13900	250	45	-	-	-	-	-	-	-	-	-	-	-	-	41800	49400	14500
	313 L1	6.50	138	16700	250	45	-	-	-	-	-	-	-	-	-	-	-	-	44100	52200	15500
	313 L2	14.2	63	21300	150	36	-	-	-	-	180	200	225	250	-	-	-	-	55800	66000	20100
	313 L2	16.9	53	25400	150	36	-	-	-	-	180	200	225	250	-	-	-	-	58800	69600	21300
	313 L2	18.5	49	27700	150	36	-	-	-	-	180	200	225	250	-	-	-	-	60400	71500	21900
	313 L2	21.8	41	29600	136	36	-	-	-	-	180	200	225	250	-	-	-	-	63400	75100	23100
	313 L2	25.8	35	30500	118	36	-	-	-	-	180	200	225	250	-	-	-	-	66800	79000	24500
	313 L2	28.4	32	31800	113	36	-	-	-	-	180	200	225	250	-	-	-	-	68700	81300	25300
	313 L2	33.6	26.7	33500	100	36	-	-	-	-	180	200	225	250	-	-	-	-	72300	85500	26700
	313 L2	40.5	22.2	32900	81	36	-	-	-	-	180	200	225	250	-	-	-	-	76400	90400	28500
	313 L3	51.1	17.6	29700	60	22	-	-	-	-	132	160	180	200	-	-	-	-	82000	97000	30800
	313 L3	61.0	14.8	35500	60	22	-	-	-	-	132	160	180	200	-	-	-	-	86400	102300	32600
	313 L3	72.0	12.5	38200	55	22	-	-	-	-	132	160	180	200	-	-	-	-	90800	107500	34500
	313 L3	78.3	11.5	43500	57	22	-	-	-	-	132	160	180	200	-	-	-	-	93100	110200	35400
	313 L3	92.4	9.7	45700	51	22	-	-	-	-	132	160	180	200	-	-	-	-	97900	115800	37500
	313 L3	110	8.2	46400	44	22	-	-	-	-	132	160	180	200	-	-	-	-	103000	122000	39700
	313 L3	121	7.5	45000	39	22	-	-	-	-	132	160	180	200	-	-	-	-	106000	125400	40900
	313 L3	135	6.7	50800	39	22	-	-	-	-	132	160	180	200	-	-	-	-	109600	129700	42500
	313 L3	143	6.3	45000	32	22	-	-	-	-	132	160	180	200	-	-	-	-	111600	132000	43300
	313 L3	151	6.0	45000	31	22	-	-	-	-	132	160	180	200	-	-	-	-	113500	134300	44100
	313 L3	163	5.5	49400	31	22	-	-	-	-	132	160	180	200	-	-	-	-	116100	137400	45300
	313 L3	176	5.1	45000	26	22	-	-	-	-	132	160	180	200	-	-	-	-	118700	140500	46400
	313 L3	82	4.9	39100	22	22	-	-	-	-	132	160	180	200	-	-	-	-	119900	142000	47000
	313 L3	194	4.6	52000	28	22	-	-	-	-	132	160	180	200	-	-	-	-	122200	144600	47900
	313 L3	209	4.3	45700	23	22	-	-	-	-	132	160	180	200	-	-	-	-	125000	147900	49100
	313 L3	252	3.6	46500	19.0	22	-	-	-	-	132	160	180	200	-	-	-	-	132300	156600	52400
	313 L3	304	3.0	41500	14.1	22	-	-	-	-	132	160	180	200	-	-	-	-	139900	165500	55700
	313 L4	352	2.6	51500	15.6	13.2	71	80	90	100	112	132	160	-	-	-	-	-	146200	173000	58500
	313 L4	394	2.3	55000	14.9	13.2	71	80	90	100	112	132	160	-	-	-	-	-	151200	179000	60700
	313 L4	452	2.0	55000	13.0	13.2	71	80	90	100	112	132	160	-	-	-	-	-	157600	186500	63600
	313 L4	514	1.8	50700	10.5	13.2	71	80	90	100	112	132	160	-	-	-	-	-	163700	193800	66400
	313 L4	564	1.6	55000	10.4	13.2	71	80	90	100	112	132	160	-	-	-	-	-	168400	199300	68500
	313 L4	633	1.4	52500	8.8	13.2	71	80	90	100	112	132	160	-	-	-	-	-	174300	206300	71100
	313 L4	695	1.3	53000	8.1	13.2	71	80	90	100	112	132	160	-	-	-	-	-	179300	212200	73400
	313 L4	790	1.1	52700	7.1	13.2	71	80	90	100	112	132	160	-	-	-	-	-	186300	220500	76600
	313 L4	889	1.0	54900	6.6	13.2	71	80	90	100	112	132	160	-	-	-	-	-	192000	228500	79700
	313 L4	1014	0.89	55000	5.8	13.2	71	80	90	100	112	132	160	-	-	-	-	-	192000	231000	80000
	313 L4	1117	0.81	52800	5.0	13.2	71	80	90	100	112	132	160	-	-	-	-	-	192000	231000	80000
	313 L4	1266	0.71	55000	4.6	13.2	71	80	90	100	112	132	160	-	-	-	-	-	192000	231000	80000
	313 L4	1394	0.65	52800	4.0	13.2	71	80	90	100	112	132	160	-	-	-	-	-	192000	231000	80000
	313 L4	1502	0.60	55000	3.9	13.2	71	80	90	100	112	132	160	-	-	-	-	-	192000	231000	80000
	313 L4	1817	0.50	55000	3.2	13.2	71	80	90	100	112	132	160	-	-	-	-	-	192000	231000	80000
	313 L4	2187	0.41	49000	2.4	13.2	71	80	90	100	112	132	160	-	-	-	-	-	192000	231000	80000

EQ314L										80000 Nm											
n <sub>1</sub> min <sup>-1</sup>	i	n <sub>2</sub> min <sup>-1</sup>	m <sub>n2</sub> Nm	P <sub>n1</sub> kW	Pt kW	P(IEC)										R <sub>n2</sub> [N]					
						MC	MZ	HC/PC	HZ/PZ	FZ	MC	MZ	HC/PC	HZ/PZ	FZ						
1400	314 L2	17.4	81	19500	175	40	-	-	-	-	200	225	250	-	-	-	-	-	55400	65100	20800
	314 L2	22.3	63	25100	175	40	-	-	-	-	200	225	250	-	-	-	-	-	59800	70200	22600
	314 L2	26.5	53	29700	175	40	-	-	-	-	200	225	250	-	-	-	-	-	62900	73900	24000
	314 L2	28.0	50	31400	175	40	-	-	-	-	200	225	250	-	-	-	-	-	64000	75100	24400
	314 L2	33.2	42	37300	175	40	-	-	-	-	200	225	250	-	-	-	-	-	67300	79100	25900
	314 L2	38.6	36	36000	145	40	-	-	-	-	200	225	250	-	-	-	-	-	70500	82700	27200
	314 L3	62.6	22.4	29200	75	25	-	-	160	180	200	225	250	-	-	-	-	-	81400	95600	31900
	314 L3	73.9	18.9	34500	75	25	-	-	160	180	200	225	250	-	-	-	-	-	85600	100500	33800
	314 L3	92.7	15.1	43300	75	25	-	-	160	180	200	225									

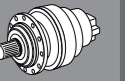
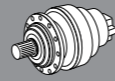

EQ315L										100000 Nm										
n <sub>1</sub> min <sup>-1</sup>		i	n <sub>2</sub> min <sup>-1</sup>	m <sub>n2</sub> Nm	P <sub>n1</sub> kW	Pt kW	P(IEC)						R <sub>n2</sub> [N]							
							MC	MZ	HC/PC	HZ/PZ	FZ	MC	MZ	HC/PC	HZ/PZ	FZ				
1400	315 L2	17.4	81	22300	200	45	-	-	-	-	-	-	55400	65100	20800	-	-	-	-	-
	315 L2	22.3	63	28600	200	45	-	-	-	-	-	-	59800	70200	22600	-	-	-	-	-
	315 L2	26.5	53	34000	200	45	-	-	-	-	-	-	62900	73900	24000	-	-	-	-	-
	315 L2	28.0	50	35900	200	45	-	-	-	-	-	-	64000	75100	24400	-	-	-	-	-
	315 L2	33.2	42	42700	200	45	-	-	-	-	-	-	67300	79100	25900	-	-	-	-	-
	315 L2	38.6	36	45000	181	45	-	-	-	-	-	-	70500	82700	27200	-	-	-	-	-
	315 L3	59.6	23.5	42700	115	30	-	-	180	200	225	250	80200	94200	31400	-	-	-	-	-
	315 L3	71.1	19.7	50900	115	30	-	-	180	200	225	250	84600	99300	33300	-	-	-	-	-
	315 L3	91.3	15.3	65400	115	30	-	-	180	200	225	250	91200	107100	36200	-	-	-	-	-
	315 L3	108	12.9	73100	108	30	-	-	180	200	225	250	96000	112700	38400	-	-	-	-	-
	315 L3	139	10.1	82800	96	30	-	-	180	200	225	250	103500	121500	41700	-	-	-	-	-
	315 L3	165	8.5	82100	80	30	-	-	180	200	225	250	108900	127900	44100	-	-	-	-	-
	315 L3	174	8.0	78300	72	30	-	-	180	200	225	250	110700	130000	45000	-	-	-	-	-
	315 L3	207	6.8	78600	61	30	-	-	180	200	225	250	116600	136900	47600	-	-	-	-	-
	315 L3	241	5.8	65000	43	30	-	-	180	200	225	250	122000	143200	50000	-	-	-	-	-
	315 L4	302	4.6	97300	53	18.0	132	160	180	200	-	-	130600	153300	54000	-	-	-	-	-
	315 L4	370	3.8	98200	44	18.0	132	160	180	200	-	-	138700	162900	57700	-	-	-	-	-
	315 L4	441	3.2	99000	37	18.0	132	160	180	200	-	-	146300	171700	61200	-	-	-	-	-
	315 L4	487	2.9	99400	34	18.0	132	160	180	200	-	-	150700	176900	63300	-	-	-	-	-
	315 L4	533	2.6	99800	31	18.0	132	160	180	200	-	-	154900	181800	65200	-	-	-	-	-
	315 L4	591	2.4	100300	28	18.0	132	160	180	200	-	-	159700	187500	67500	-	-	-	-	-
	315 L4	672	2.1	101000	25	18.0	132	160	180	200	-	-	165900	194800	70500	-	-	-	-	-
	315 L4	742	1.9	101500	23	18.0	132	160	180	200	-	-	170900	200700	72800	-	-	-	-	-
	315 L4	862	1.6	102300	19.7	18.0	132	160	180	200	-	-	178800	210000	76600	-	-	-	-	-
	315 L4	930	1.5	93500	16.6	18.0	132	160	180	200	-	-	183000	214800	78500	-	-	-	-	-
	315 L4	1043	1.3	103400	16.4	18.0	132	160	180	200	-	-	189400	222300	81600	-	-	-	-	-
	315 L4	1104	1.3	95700	14.4	18.0	132	160	180	200	-	-	192600	226200	83200	-	-	-	-	-
	315 L4	1284	1.1	97800	12.6	18.0	132	160	180	200	-	-	201500	236600	87400	-	-	-	-	-
	315 L4	1492	0.94	80000	8.9	18.0	132	160	180	200	-	-	206000	243000	90000	-	-	-	-	-
	315 L4	1805	0.78	80000	7.3	18.0	132	160	180	200	-	-	206000	243000	90000	-	-	-	-	-
900	315 L2	17.4	52	34700	200	54	-	-	-	-	-	-	63300	74300	24100	-	-	-	-	-
	315 L2	22.3	40	44600	200	54	-	-	-	-	-	-	68200	80100	26200	-	-	-	-	-
	315 L2	26.5	34	52900	200	54	-	-	-	-	-	-	71800	84300	27800	-	-	-	-	-
	315 L2	28.0	32	55500	199	54	-	-	-	-	-	-	73000	85800	28300	-	-	-	-	-
	315 L2	33.2	27.1	58300	176	54	-	-	-	-	-	-	76900	90300	30000	-	-	-	-	-
	315 L2	38.6	23.3	51000	132	54	-	-	-	-	-	-	80400	94400	31500	-	-	-	-	-
	315 L3	59.6	15.1	66400	115	36	-	-	180	200	225	250	91600	107600	36400	-	-	-	-	-
	315 L3	71.1	12.7	73600	107	36	-	-	180	200	225	250	96600	113400	38600	-	-	-	-	-
	315 L3	91.3	9.9	79300	90	36	-	-	180	200	225	250	104100	122200	42000	-	-	-	-	-
	315 L3	108	8.3	83500	80	36	-	-	180	200	225	250	109600	128700	44400	-	-	-	-	-
	315 L3	139	6.5	91500	68	36	-	-	180	200	225	250	118100	138700	48300	-	-	-	-	-
	315 L3	165	5.5	94400	59	36	-	-	180	200	225	250	124300	146000	51100	-	-	-	-	-
	315 L3	174	5.2	79000	47	36	-	-	180	200	225	250	126400	148500	52100	-	-	-	-	-
	315 L3	207	4.3	80600	40	36	-	-	180	200	225	250	133100	156300	55100	-	-	-	-	-
	315 L3	241	3.7	67100	29	36	-	-	180	200	225	250	139300	163500	58000	-	-	-	-	-
	315 L4	302	3.0	99200	35	22	132	160	180	200	-	-	149100	175100	62600	-	-	-	-	-
	315 L4	370	2.4	100100	29	22	132	160	180	200	-	-	158400	186000	66900	-	-	-	-	-
	315 L4	441	2.0	101100	24	22	132	160	180	200	-	-	167000	196100	71000	-	-	-	-	-
	315 L4	487	1.8	101600	22	22	132	160	180	200	-	-	172000	202000	73300	-	-	-	-	-
	315 L4	533	1.7	102100	20	22	132	160	180	200	-	-	176800	207600	75600	-	-	-	-	-
	315 L4	591	1.5	102700	18.5	22	132	160	180	200	-	-	182300	214100	78200	-	-	-	-	-
	315 L4	672	1.3	103400	16.4	22	132	160	180	200	-	-	189500	222400	81600	-	-	-	-	-
	315 L4	741	1.2	103900	14.9	22	132	160	180	200	-	-	195200	229100	84400	-	-	-	-	-
	315 L4	862	1.0	104800	12.9	22	132	160	180	200	-	-	204200	239700	88700	-	-	-	-	-
	315 L4	931	0.97	99000	11.3	22	132	160	180	200	-	-	206000	243000	90000	-	-	-	-	-
	315 L4	1043	0.86	105000	10.7	22	132	160	180	200	-	-	206000	243000	90000	-	-	-	-	-
	315 L4	1104	0.82	99000	9.5	22	132	160	180	200	-	-	206000	243000	90000	-	-	-	-	-
	315 L4	1284	0.70	99000	8.2	22	132	160	180	200	-	-	206000	243000	90000	-	-	-	-	-
	315 L4	1492	0.60	80000	5.7	22	132	160	180	200	-	-	206000	243000	90000	-	-	-	-	-
	315 L4	1805	0.50	80000	4.7	22	132	160	180	200	-	-	206000	243000	90000	-	-	-	-	-

EQ316L										135000 Nm										
n <sub>1</sub> min <sup>-1</sup>		i	n <sub>2</sub> min <sup>-1</sup>	m <sub>n2</sub> Nm	P <sub>n1</sub> kW	Pt kW	P(IEC)						R <sub>n2</sub> [N]							
							MC	MZ	HC/PC	HZ/PZ	FZ	MC	MZ	HC/PC	HZ/PZ	FZ				
1400	316 L2	17.4	81	22300	200	50	-	-	-	-	-	-	-	-	-	92200	102500	34700	-	-
	316 L2	22.3	63	28600	200	50	-	-	-	-	-	-	-	-	-	99400	110500	37700	-	-
	316 L2	26.5	53	34000	200	50	-	-	-	-	-	-	-	-	-	104600	116300	40000	-	-
	316 L3	59.6	23.5	42700	115	35	-	-	180	200	225	250	-	-	-	133400	148400	52400	-	-
	316 L3	71.1	19.7	50900	115	35	-	-	180	200	225	250	-	-	-	140700	156500	55600	-	-
	316 L3	76.5	18.3	54800	115	35	-	-	180	200	225	250	-	-	-	143800	159900	56900	-	-
	316 L3	91.3	15.3	65400	115	35	-	-	180	200	225	250	-	-	-	151600	168600	60400	-	-
	316 L3	108	12.9	77500	115	35	-	-	180	200	225	250	-	-	-	159600	177500	63900	-	-
	316 L3	117	12.0	81000	111	35	-	-	180	200	225	250	-	-	-	163400	181700	65600	-	-
	316 L3	139	10.1	83500	97	35	-	-	180	200	225	250	-	-	-	172000	191300	69500	-	-
	316 L3	165	8.5	83600	81	35	-	-	180	200	225	250	-	-	-	181100	201400	73500	-	-
	316 L4	215	6.5	77800	60	18.0	132	160	180	200	-	-	-	-	-	195900	217900	80300	-	-
	316 L4	256	5.5	92800	60	18.0	132	160	180	200	-	-	-	-						

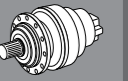
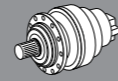

EQ317L										170000 Nm							
n <sub>1</sub> min <sup>-1</sup>	i	n <sub>2</sub> min <sup>-1</sup>	m <sub>n2</sub> Nm	P <sub>n1</sub> kW	Pt kW	P(IEC)						R <sub>n2</sub> [N]					
						MC	MZ	HC/PC	HZ/PZ	FZ	MC	MZ	HC/PC	HZ/PZ	FZ		
1400	317 L3	58.1	24.1	54300	150	35	-	-	180	200	225	250	-	-	170200	181300	51900
	317 L3	69.3	20.2	64700	150	35	-	-	180	200	225	250	-	-	179500	191100	55100
	317 L3	89.0	15.7	83100	150	35	-	-	180	200	225	250	-	-	193500	206000	59900
	317 L3	106	13.3	98600	150	35	-	-	180	200	225	250	-	-	203700	216800	63400
	317 L3	116	12.1	108300	150	35	-	-	180	200	225	250	-	-	209500	223000	65400
	317 L3	138	10.2	116400	136	35	-	-	180	200	225	250	-	-	220500	234800	69200
	317 L3	166	8.4	123100	119	35	-	-	180	200	225	250	-	-	233100	248200	73600
	317 L3	179	7.8	133800	120	35	-	-	180	200	225	250	-	-	238700	254100	75600
	317 L3	213	6.6	136500	103	35	-	-	180	200	225	250	-	-	251200	267500	80000
	317 L3	252	5.5	115000	73	35	-	-	180	200	225	250	-	-	264500	281600	84700
	317 L4	310	4.5	112300	60	18.0	132	160	180	200	-	-	-	-	281300	299500	90700
	317 L4	360	3.9	120500	55	18.0	132	160	180	200	-	-	-	-	294300	313300	95400
	317 L4	449	3.1	162600	60	18.0	132	160	180	200	-	-	-	-	314300	334700	102700
	317 L4	493	2.8	170400	57	18.0	132	160	180	200	-	-	-	-	323300	344200	105900
	317 L4	552	2.5	178200	53	18.0	132	160	180	200	-	-	-	-	334400	356100	110000
	317 L4	619	2.3	177200	47	18.0	132	160	180	200	-	-	-	-	346100	368500	114200
	317 L4	719	1.9	177500	41	18.0	132	160	180	200	-	-	-	-	362100	385500	120100
	317 L4	792	1.8	176900	37	18.0	132	160	180	200	-	-	-	-	372700	396900	124100
	317 L4	904	1.5	161700	30	18.0	132	160	180	200	-	-	-	-	387800	412900	129600
	317 L4	1032	1.4	178300	29	18.0	132	160	180	200	-	-	-	-	403600	429700	135500
	317 L4	1134	1.2	165900	24	18.0	132	160	180	200	-	-	-	-	415100	442000	139800
	317 L4	1318	1.1	145100	18.2	18.0	132	160	180	200	-	-	-	-	434300	462400	147000
	317 L4	1595	0.88	170000	17.7	18.0	132	160	180	200	-	-	-	-	442000	470000	150000
	317 L4	1893	0.74	145000	12.7	18.0	132	160	180	200	-	-	-	-	442000	470000	150000
900	317 L2	16.9	53	42300	250	55	-	-	-	-	-	-	-	-	134300	143000	39900
	317 L2	22.1	41	55100	250	55	-	-	-	-	-	-	-	-	145400	154800	43600
	317 L2	26.6	34	66400	250	55	-	-	-	-	-	-	-	-	153700	163700	46400
	317 L2	28.4	32	70800	250	55	-	-	-	-	-	-	-	-	156700	166900	47400
	317 L2	34.1	26.4	85200	250	55	-	-	-	-	-	-	-	-	165700	176400	50400
	317 L2	40.5	22.2	94900	235	55	-	-	-	-	-	-	-	-	174400	185700	53400
	317 L3	58.1	15.5	84400	150	42	-	-	180	200	225	250	-	-	194400	206900	60200
	317 L3	69.3	13.0	100700	150	42	-	-	180	200	225	250	-	-	204900	218200	63800
	317 L3	89.0	10.1	117600	136	42	-	-	180	200	225	250	-	-	220900	235200	69400
	317 L3	106	8.5	120700	118	42	-	-	180	200	225	250	-	-	232500	247600	73400
	317 L3	116	7.8	126200	112	42	-	-	180	200	225	250	-	-	239200	254600	75800
	317 L3	138	6.5	132900	100	42	-	-	180	200	225	250	-	-	251800	268100	80200
	317 L3	166	5.4	140500	88	42	-	-	180	200	225	250	-	-	266200	283400	85300
	317 L3	179	5.0	140900	81	42	-	-	180	200	225	250	-	-	272500	290100	87600
	317 L3	213	4.2	143800	70	42	-	-	180	200	225	250	-	-	286800	305400	92700
	317 L3	252	3.6	120200	49	42	-	-	180	200	225	250	-	-	302000	321500	98200
	317 L4	310	2.9	132900	46	22	132	160	180	200	-	-	-	-	321200	341900	105100
	317 L4	360	2.5	137000	40	22	132	160	180	200	-	-	-	-	336000	357700	110500
	317 L4	449	2.0	176200	42	22	132	160	180	200	-	-	-	-	358900	382100	118900
	317 L4	493	1.8	177700	38	22	132	160	180	200	-	-	-	-	369100	393000	122700
	317 L4	552	1.6	179500	35	22	132	160	180	200	-	-	-	-	381800	406500	127400
	317 L4	619	1.5	178200	31	22	132	160	180	200	-	-	-	-	395200	420700	132400
	317 L4	719	1.3	178500	26	22	132	160	180	200	-	-	-	-	413400	440200	139200
	317 L4	792	1.1	179300	24	22	132	160	180	200	-	-	-	-	425600	453100	143700
	317 L4	904	1.00	170000	20	22	132	160	180	200	-	-	-	-	442000	470000	150000
	317 L4	1032	0.87	179000	18.5	22	132	160	180	200	-	-	-	-	442000	470000	150000
	317 L4	1134	0.79	170000	16.0	22	132	160	180	200	-	-	-	-	442000	470000	150000
	317 L4	1318	0.68	170000	13.7	22	132	160	180	200	-	-	-	-	442000	470000	150000
	317 L4	1595	0.56	170000	11.3	22	132	160	180	200	-	-	-	-	442000	470000	150000
	317 L4	1893	0.48	145000	8.2	22	132	160	180	200	-	-	-	-	442000	470000	150000

EQ318L										250000 Nm									
n <sub>1</sub> min <sup>-1</sup>	i	n <sub>2</sub> min <sup>-1</sup>	m <sub>n2</sub> Nm	P <sub>n1</sub> kW	Pt kW	P(IEC)						R <sub>n2</sub> [N]							
						MC	MZ	HC/PC	HZ/PZ	FZ	MC	MZ	HC/PC	HZ/PZ	FZ				
1400	318 L3	76.5	18.3	95300	200	40	-	-	-	-	-	-	-	-	-	-	232000	236700	75900
	318 L3	98.2	14.3	122200	200	40	-	-	-	-	-	-	-	-	-	-	250000	255100	82500
	318 L3	117	12.0	145100	200	40	-	-	-	-	-	-	-	-	-	-	263200	268600	87300
	318 L3	123	11.4	153400	200	40	-	-	-	-	-	-	-	-	-	-	267600	273100	89000
	318 L3	146	9.6	175300	193	40	-	-	-	-	-	-	-	-	-	-	281700	287500	94200
	318 L3	170	8.2	182400	172	40	-	-	-	-	-	-	-	-	-	-	294700	300800	99000
	318 L4	262	5.3	182200	115	22	180	200	225	250	-	-	-	-	-	-	335700	342600	114400
	318 L4	313	4.5	217300	115	22	180	200	225	250	-	-	-	-	-	-	353900	361200	121400
	318 L4	337	4.2	222300	109	22	180	200	225	250	-	-	-	-	-	-	361800	369200	124400
	318 L4	402	3.5	231500	95	22	180	200	225	250	-	-	-	-	-	-	381500	389300	131900
	318 L4	422	3.3	234200	92	22	180	200	225	250	-	-	-	-	-	-	387300	395200	134100
	318 L4	477	2.9	240900	84	22	180	200	225	250	-	-	-	-	-	-	401600	409800	139700
	318 L4	515	2.7	245300	79	22	180	200	225	250	-	-	-	-	-	-	411100	419500	143300
	318 L4	612	2.3	250000	68	22	180	200	225	250	-	-	-	-	-	-	432800	441700	151800
	318 L4	647	2.2	250000	64	22	180	200	225	250	-	-	-	-	-	-	440100	449100	154600
	318 L4	726	1.9	250000	57	22	180	200	225	250	-	-	-	-	-	-	455600	464900	160700
	318 L4	768	1.8	250000	54	22	180	200	225	250	-	-	-	-	-	-	463300	472800	163700
	318 L4	911	1.5	250000	45	22	180	200	225	250	-	-	-	-	-	-	487700	497700	173300
	318 L4	1059	1.3	232800	36	22	180	200	225	250	-	-	-	-	-	-	503000	520700	182200
900	318 L3	76.5	11.8	148200	200	48	-	-	-	-	-	-	-	-	-	-	264800	270300	87900
	318 L3	98.2	9.2	177600	187	48	-	-	-	-	-	-	-	-	-	-	285400	291300	95600
	318 L3	117	7.7	186900	166	48	-	-	-	-	-	-	-	-	-	-	300500	306600	101200
	318 L3	123	7.3	190100	159	48	-	-	-	-	-	-	-	-	-	-	305500	311800	103100
	318 L3	146	6.2	200100	141	48	-	-	-	-	-	-	-	-	-	-	321600	328200	109100
	318 L3																		

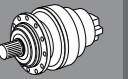

EQ319L							350000 Nm							
n <sub>1</sub> min <sup>-1</sup>	i	n <sub>2</sub> min <sup>-1</sup>	m <sub>n2</sub> Nm	P <sub>n1</sub> kW	Pt kW	P(IEC)	R <sub>n2</sub> [N]							
							MC	MZ	HC/PC	HZ/PZ	FZ			
1400	319 L3	84.8	16.5	60700	115	50	-	-	-	-	-	274900	302900	78500
	319 L3	109	12.9	77900	115	50	-	-	-	-	-	296300	326400	85300
	319 L3	129	10.8	92400	115	50	-	-	-	-	-	311900	343600	90400
	319 L3	137	10.3	97700	115	50	-	-	-	-	-	317200	349400	92100
	319 L3	162	8.7	115700	115	50	-	-	-	-	-	333600	367600	97400
	319 L3	188	7.4	134800	115	50	-	-	-	-	-	349300	384900	102500
	319 L3	223	6.3	159600	115	50	-	-	-	-	-	367400	404800	108400
	319 L4	347	4.0	125600	60	30	180	200	225	250	-	419500	462200	125600
	319 L4	445	3.1	161200	60	30	180	200	225	250	-	452100	498100	136500
	319 L4	528	2.7	191400	60	30	180	200	225	250	-	476000	524400	144500
	319 L4	571	2.5	206900	60	30	180	200	225	250	-	487300	536800	148300
	319 L4	678	2.1	245600	60	30	180	200	225	250	-	513000	565100	157000
	319 L4	717	2.0	259700	60	30	180	200	225	250	-	521600	574700	160000
	319 L4	851	1.6	308200	60	30	180	200	225	250	-	549100	605000	169400
319 L4	912	1.5	316600	58	30	180	200	225	250	-	560700	617700	173400	
319 L4	1007	1.4	321900	53	30	180	200	225	250	-	577600	636300	179200	
319 L4	1195	1.2	331200	46	30	180	200	225	250	-	608000	669900	189700	
319 L4	1389	1.0	339500	40	30	180	200	225	250	-	636100	700800	199500	
900	319 L3	84.8	10.6	94400	115	60	-	-	-	-	-	313900	345800	91000
	319 L3	109	8.3	121100	115	60	-	-	-	-	-	338300	372700	98900
	319 L3	129	7.0	143800	115	60	-	-	-	-	-	356100	392400	104700
	319 L3	137	6.6	152000	115	60	-	-	-	-	-	362100	399000	106700
	319 L3	162	5.6	179900	115	60	-	-	-	-	-	380900	419700	112800
	319 L3	188	4.8	209700	115	60	-	-	-	-	-	398800	439400	118700
	319 L3	223	4.0	248200	115	60	-	-	-	-	-	419500	462200	125600
	319 L4	347	2.6	195400	60	36	180	200	225	250	-	479000	527700	145500
	319 L4	445	2.0	250800	60	36	180	200	225	250	-	516200	568700	158100
	319 L4	528	1.7	297700	60	36	180	200	225	250	-	543400	598700	167400
	319 L4	571	1.6	321900	60	36	180	200	225	250	-	556300	612900	171900
	319 L4	678	1.3	349400	55	36	180	200	225	250	-	585700	645300	182000
	319 L4	717	1.3	349500	52	36	180	200	225	250	-	595500	656100	185400
	319 L4	850	1.1	349900	44	36	180	200	225	250	-	626900	690700	196300
319 L4	912	0.99	340000	40	36	180	200	225	250	-	638000	702000	200000	
319 L4	1007	0.89	340000	36	36	180	200	225	250	-	638000	702000	200000	
319 L4	1195	0.75	340000	30	36	180	200	225	250	-	638000	702000	200000	
319 L4	1389	0.65	340000	26	36	180	200	225	250	-	638000	702000	200000	

EQ321L							500000 Nm									
n <sub>1</sub> min <sup>-1</sup>	i	n <sub>2</sub> min <sup>-1</sup>	m <sub>n2</sub> Nm	P <sub>n1</sub> kW	Pt kW	P(IEC)	R <sub>n2</sub> [N]									
							MC	MZ	HC/PC	HZ/PZ	FZ					
1400	321 L4	258	5.4	233900	150	35	180	200	225	250	-	-	471100	558700	683100	
	321 L4	308	4.5	279100	150	35	180	200	225	250	-	-	496800	589100	724500	
	321 L4	395	3.5	358200	150	35	180	200	225	250	-	-	535400	634900	787400	
	321 L4	469	3.0	425100	150	35	180	200	225	250	-	-	563600	668300	833600	
	321 L4	515	2.7	457200	147	35	180	200	225	250	-	-	579700	687400	860100	
	321 L4	612	2.3	472700	128	35	180	200	225	250	-	-	610200	723600	910600	
	321 L4	736	1.9	487000	110	35	180	200	225	250	-	-	645100	765000	968700	
	321 L4	796	1.8	489200	102	35	180	200	225	250	-	-	660400	783200	994200	
	321 L4	945	1.5	504100	88	35	180	200	225	250	-	-	695300	824500	1052600	
	321 L4	1122	1.2	490100	72	35	180	200	225	250	-	-	731900	867900	1114500	
	900	321 L3	75.3	11.9	182400	250	60	-	-	-	-	-	-	371700	440800	524900
		321 L3	98.2	9.2	237700	250	60	-	-	-	-	-	-	402400	477200	573400
		321 L3	118	7.6	286100	250	60	-	-	-	-	-	-	425400	504500	609900
		321 L3	126	7.1	305100	250	60	-	-	-	-	-	-	433700	514300	623100
321 L3		152	5.9	367200	250	60	-	-	-	-	-	-	458500	543700	662800	
321 L3		180	5.0	415000	238	60	-	-	-	-	-	-	482700	572400	701800	
321 L4		258	3.5	363900	150	42	180	200	225	250	-	-	537900	637900	791500	
321 L4		308	2.9	434200	150	42	180	200	225	250	-	-	567200	672600	839500	
321 L4		395	2.3	473100	127	42	180	200	225	250	-	-	611200	724800	912300	
321 L4		469	1.9	486300	110	42	180	200	225	250	-	-	643500	763100	965900	
321 L4		515	1.7	493700	102	42	180	200	225	250	-	-	661800	784800	996500	
321 L4		612	1.5	507500	88	42	180	200	225	250	-	-	696700	826200	1055100	
321 L4		736	1.2	522800	76	42	180	200	225	250	-	-	736600	873500	1122400	
321 L4		796	1.1	528500	71	42	180	200	225	250	-	-	754000	894200	1152000	
321 L4	945	0.95	540000	61	42	180	200	225	250	-	-	779000	923000	1200000		
321 L4	1122	0.80	498000	47	42	180	200	225	250	-	-	779000	923000	1200000		

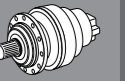
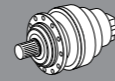

查阅额定值表说明  
Refer to the rated value table for instructions

①

EQ310R								25000 Nm							
n <sub>1</sub> min <sup>-1</sup>	i	n <sub>2</sub> min <sup>-1</sup>	m <sub>n2</sub> Nm	P <sub>n1</sub> kW	Pt kW	P(IEC)	R <sub>n2</sub> [N]	R <sub>n2</sub> [N]							
								MC	MZ	HC/PC	HZ/PZ	FZ			
1400	310 R2 (B)	12.0	117	10000	130	55	-- -- -- --	-- --	31800	40000	13300				
	310 R2 (B)	15.4	91	10600	107	55	-- -- -- --	-- --	34300	43100	14500				
	310 R2 (B)	18.3	77	11100	94	55	-- -- -- --	-- --	36100	45400	15300				
	310 R2 (C)	16.6	84	10700	100	55	-- -- -- --	-- --	35100	44100	14800				
	310 R2 (C)	21.3	66	11700	85	55	-- -- -- --	-- --	37800	47600	16100				
	310 R2 (C)	25.3	55	12200	75	55	-- -- -- --	-- --	39800	50100	17100				

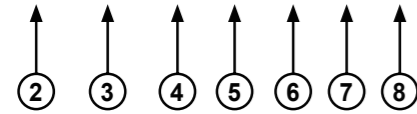

- 1 最大输出转矩。  
1 Maximum output torque.
- 2 齿轮箱输入转速。  
2 Input speed of gearbox.
- 3 直角式齿轮箱的机座号 注意：靠近机座号的字母 (A) (B) (C) 表明不同尺寸的标志。参见相应尺寸页面。  
3 Attention to the machine base number of the right angle gearbox: The letters [A], [B], and [C] near the machine base number indicate different sizes of markings. Refer to the corresponding size page.
- 4 传动比。  
4 Transmission ratios.
- 5 齿轮箱输出转速。  
5 Gearbox output speed.
- 6 齿轮箱额定输出转矩, 条件: 安全系数S=1 假设使用寿命10000小时。  
6 Rated output torque of gearbox, condition: safety factor S=1, assuming a service life of 10000 hours.
- 7 齿轮箱额定输入转矩, 条件: 安全系数S=1 假设使用寿命10000小时。  
7 Rated input torque of gearbox, condition: safety factor S=1, assuming a service life of 10000 hours.
- 8 齿轮箱热功率。  
8 Gearbox thermal power.
- 9 可用的IEC电机的机座号。  
9 Available IEC motor frame numbers.
- 10 在输出轴上的允许悬臂荷载, 条件: 安全系数S=1 假设使用寿命10000小时 当作用力没有应用在轴中点, 按照具体齿轮箱的尺寸查看规定的图表。  
10 Allowable cantilever load on the output shaft, condition: safety factor S=1. Assuming a service life of 10000 hours, it is assumed that no force is applied at the midpoint of the shaft. Refer to the specified chart based on the size of the gearbox.

EQ300R								1000 Nm							
n <sub>1</sub> min <sup>-1</sup>	i	n <sub>2</sub> min <sup>-1</sup>	m <sub>n2</sub> Nm	P <sub>n1</sub> kW	Pt kW	P(IEC)	R <sub>n2</sub> [N]	R <sub>n2</sub> [N]							
								MC	MZ	HC/PC	HZ/PZ	FZ			
1400	300 R2	7.13	196	520	11.4	12.0	71 80 90 100 112 132	2090	2090	6300	7230	1380			
	300 R2	8.74	160	530	9.4	12.0	71 80 90 100 112 132	2240	2240	6690	7690	1470			
	300 R2	11.8	118	550	7.3	12.0	71 80 90 100 112 132	2480	2480	7330	8420	1630			
	300 R2	14.8	95	510	5.4	12.0	71 80 90 100 112 132	2670	2670	7830	9000	1750			
	300 R2	18.5	76	370	3.1	12.0	71 80 90 100 112 132	2870	2870	8370	9620	1890			
	300 R3	24.8	56	650	4.2	12.0	71 80 90 100 112 132	3170	3170	7380	9150	2090			
	300 R3	30.4	46	760	4.0	12.0	71 80 90 100 112 132	3400	3400	7840	9730	2230			
	300 R3	37.3	38	780	3.3	12.0	71 80 90 100 112 132	3630	3630	8330	10300	2390			
	300 R3	41.2	34	650	2.5	12.0	71 80 90 100 112 132	3760	3760	8590	10600	2470			
	300 R3	50.4	27.8	790	2.5	12.0	71 80 90 100 112 132	4020	4020	9130	11300	2640			
	300 R3	62.9	22.2	800	2.1	12.0	71 80 90 100 112 132	4330	4330	9750	12100	2840			
	300 R3	68.2	20.5	650	1.5	12.0	71 80 90 100 112 132	4440	4440	9990	12400	2920			
	300 R3	78.7	17.8	820	1.7	12.0	71 80 90 100 112 132	4660	4660	10400	12900	3060			
	300 R3	85.2	16.4	650	1.2	12.0	71 80 90 100 112 132	4790	4790	10700	13200	3150			
	300 R3	107	13.2	650	0.98	12.0	71 80 90 100 112 132	5160	5160	11400	14200	3390			
	300 R3	133	10.5	550	0.67	12.0	71 80 90 100 112 132	5550	5550	12200	15100	3650			
	300 R4	106	13.2	830	1.3	10.0	71 80 90 100 112 132	5150	5150	14100	16200	3380			
	300 R4	130	10.8	850	1.1	10.0	71 80 90 100 112 132	5510	5510	15000	17300	3620			
	300 R4	143	9.8	650	0.75	10.0	71 80 90 100 112 132	5690	5690	15500	17800	3740			
	300 R4	159	8.8	860	0.89	10.0	71 80 90 100 112 132	5890	5890	16000	18300	3870			
	300 R4	175	8.0	860	0.81	10.0	71 80 90 100 112 132	6090	6090	16500	18900	4000			
	300 R4	215	6.5	870	0.67	10.0	71 80 90 100 112 132	6520	6520	17500	20100	4280			
	300 R4	237	5.9	650	0.45	10.0	71 80 90 100 112 132	6740	6740	18000	20700	4430			
	300 R4	268	5.2	890	0.55	10.0	71 80 90 100 112 132	7020	7020	18700	21500	4610			
	300 R4	291	4.8	900	0.51	10.0	71 80 90 100 112 132	7210	7210	19100	22000	4740			
	300 R4	363	3.9	930	0.42	10.0	71 80 90 100 112 132	7760	7760	20500	23500	5100			
	300 R4	394	3.6	690	0.29	10.0	71 80 90 100 112 132	7970	7970	21000	24100	5240			
	300 R4	453	3.1	960	0.35	10.0	71 80 90 100 112 132	8350	8350	21900	25100	5490			
	300 R4	491	2.8	710	0.24	10.0	71 80 90 100 112 132	8580	8580	22400	25700	5640			
	300 R4	613	2.3	740	0.20	10.0	71 80 90 100 112 132	9240	9240	23900	27500	6080			
	300 R4	766	1.8	770	0.17	10.0	71 80 90 100 112 132	9950	9950	25600	29400	6540			
900	300 R2	7.13	126	600	8.4	14.4	71 80 90 100 112 132	2430	2430	7190	8260	1600			
	300 R2	8.74	103	600	6.9	14.4	71 80 90 100 112 132	2600	2600	7640	8780	1710			
	300 R2	11.8	76	610	5.1	14.4	71 80 90 100 112 132	2870	2870	8360	9610	1890			
	300 R2	14.8	61	540	3.7	14.4	71 80 90 100 112 132	3090	3090	8940	10300	2030			
	300 R2	18.5	49	370	2.0	14.4	71 80 90 100 112 132	3330	3330	9560	11000	2190			
	300 R3	24.8	36	650	2.7	14.4	71 80 90 100 112 132	3680	3680	10400	12000	2420			
	300 R3	30.4	29.6	790	2.7	14.4	71 80 90 100 112 132	3930	3930	11100	12800	2590			
	300 R3	37.3	24.2	800	2.2	14.4	71 80 90 100 112 132	4210	4210	11800	13600	2770			
	300 R3	41.2	21.9	650	1.6	14.4	71 80 90 100 112 132	4350	4350	12200	14000	2860			
	300 R3	50.4	17.9	820	1.7	14.4	71 80 90 100 112 132	4660	4660	12900	14800	3060			
	300 R3	62.9	14.3	830	1.4	14.4	71 80 90 100 112 132	5010	5010	13800	15900	3300			
	300 R3	68.2	13.2	650	0.98	14.4	71 80 90 100 112 132	5150	5150	14200	16300	3390			
	300 R3	78.7	11.4	840	1.1	14.4	71 80 90 100 112 132	5400	5400	14800	17000	3550			
	300 R3	85.2	10.6	650	0.79	14.4	71 80 90 100 112 132	5540	5540	15100	17400	3650			
	300 R3	107	8.5	650	0.63	14.4	71 80 90 100 112 132	5970	5970	16200	18600	3930			
	300 R3	133	6.8	550	0.43	14.4	71 80 90 100 112 132	6430	6430	17300	19900	4230			
	300 R4	106	8.5	860	0.86	12.0	71 80 90 100 112 132	5960	5960	16100	18500	3920			
	300 R4	130	6.9	870	0.71	12.0	71 80 90 100 112 132	6380	6380	17200	19700	4190			
	300 R4	143	6.3	650	0.48	12.0	71 80 90 100 112 132	6590	6590	17700	20300	4340			
	300 R4	159	5.7	880	0.59	12.0	71 80 90 100 112 132	6830	6830	18200	20900	4490			
	300 R4	175	5.1	890	0.54	12.0	71 80 90 100 112 132	7060	7060	18800	21600	4640			
	300 R4	215	4.2	920	0.45	12.0	71 80 90 100 112 132	7550	7550	20000	22900	4960			
	300 R4	237	3.8	680	0.31	12.0	71 80 90 100 112 132	7800	7800	20600	23600	5130			
	300 R4	268	3.4	950	0.38	12.0	71 80 90 100 112 132	8130	8130	21300	24500	5340			
	300 R4	291	3.1	960	0.35	12.0	71 80 90 100 112 132	8350	8350	21900	25100	5490			
	300 R4	363	2.5	1000	0.29	12.0	71 80 90 100 112 132	8990	8990	23400	26800	5910			
	300 R4	394	2.3	740	0.20	12.0	71 80 90 100 112 132	9240	9240	23900	27500	6070			
	300 R4	453	2.0	1000	0.23	12.0	71 80 90 100 112 132	9680	9680	25000	28700	6360			
	300 R4	491	1.8	770	0.17	12.0	71 80 90 100 112 132	9940	9940	25600	29400	6540			
	300 R4	613	1.5	800	0.14	12.0	71 80 90 100 112 132	10700	10700	27300	31400	7040			
	300 R4	766	1.2	840	0.12	12.0	71 80 90 100 112 132	11500	11500	29200	33600	7580			

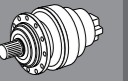
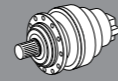

EQ301R							1750 Nm										
n <sub>1</sub> min <sup>-1</sup>	i	n <sub>2</sub> min <sup>-1</sup>	m <sub>n2</sub> Nm	P <sub>n1</sub> kW	Pt kW	IEC	R <sub>n2</sub> [N]										
							MC	MZ	HC/PC	HZ/PZ	FZ						
1400	301 R2	7.13	196	690	15.0	12.0	71	80	90	100	112	132	2090	2090	6300	7230	1380
	301 R2	8.74	160	840	15.0	12.0	71	80	90	100	112	132	2240	2240	6690	7690	1470
	301 R2	11.8	118	1000	13.1	12.0	71	80	90	100	112	132	2480	2480	7330	8420	1630
	301 R2	14.8	95	950	10.1	12.0	71	80	90	100	112	132	2670	2670	7830	9000	1750
	301 R2	18.5	76	660	5.6	12.0	71	80	90	100	112	132	2870	2870	8370	9620	1890
	301 R3	24.8	56	1260	8.2	12.0	71	80	90	100	112	132	3170	3170	9150	10500	2090
	301 R3	30.4	46	1370	7.2	12.0	71	80	90	100	112	132	3400	3400	9730	11200	2230
	301 R3	37.3	38	1410	6.1	12.0	71	80	90	100	112	132	3630	3630	10300	11900	2390
	301 R3	41.2	34	1300	5.1	12.0	71	80	90	100	112	132	3760	3760	10600	12200	2470
	301 R3	50.4	27.8	1470	4.7	12.0	71	80	90	100	112	132	4020	4020	11300	13000	2640
	301 R3	62.9	22.2	1520	3.9	12.0	71	80	90	100	112	132	4330	4330	12100	13900	2840
	301 R3	68.2	20.5	1300	3.1	12.0	71	80	90	100	112	132	4440	4440	12400	14200	2920
	301 R3	78.7	17.8	1490	3.0	12.0	71	80	90	100	112	132	4660	4660	12900	14900	3060
	301 R3	85.2	16.4	1300	2.5	12.0	71	80	90	100	112	132	4790	4790	13200	15200	3150
	301 R3	107	13.2	1300	2.0	12.0	71	80	90	100	112	132	5160	5160	14200	16300	3390
	301 R3	133	10.5	1150	1.4	12.0	71	80	90	100	112	132	5550	5550	15100	17400	3650
	301 R4	106	13.2	1630	2.6	10.0	71	80	90	100	112	132	5150	5150	14100	16200	3380
	301 R4	130	10.8	1680	2.1	10.0	71	80	90	100	112	132	5510	5510	15000	17300	3620
	301 R4	143	9.8	1300	1.5	10.0	71	80	90	100	112	132	5690	5690	15500	17800	3740
	301 R4	159	8.8	1710	1.8	10.0	71	80	90	100	112	132	5890	5890	16000	18300	3870
301 R4	175	8.0	1720	1.6	10.0	71	80	90	100	112	132	6090	6090	16500	18900	4000	
301 R4	215	6.5	1730	1.3	10.0	71	80	90	100	112	132	6520	6520	17500	20100	4280	
301 R4	237	5.9	1300	0.91	10.0	71	80	90	100	112	132	6740	6740	18000	20700	4430	
301 R4	268	5.2	1750	1.1	10.0	71	80	90	100	112	132	7020	7020	18700	21500	4610	
301 R4	291	4.8	1760	1.0	10.0	71	80	90	100	112	132	7210	7210	19100	22000	4740	
301 R4	363	3.9	1840	0.84	10.0	71	80	90	100	112	132	7760	7760	20500	23500	5100	
301 R4	394	3.6	1370	0.58	10.0	71	80	90	100	112	132	7970	7970	21000	24100	5240	
301 R4	453	3.1	1920	0.70	10.0	71	80	90	100	112	132	8350	8350	21900	25100	5490	
301 R4	491	2.8	1420	0.48	10.0	71	80	90	100	112	132	8580	8580	22400	25700	5640	
301 R4	613	2.3	1470	0.40	10.0	71	80	90	100	112	132	9240	9240	23900	27500	6080	
301 R4	766	1.8	1530	0.33	10.0	71	80	90	100	112	132	9950	9950	25600	29400	6540	
900	301 R2	7.13	126	830	11.7	14.4	71	80	90	100	112	132	2430	2430	7190	8260	1600
	301 R2	8.74	103	1040	11.9	14.4	71	80	90	100	112	132	2600	2600	7640	8780	1710
	301 R2	11.8	76	1140	9.7	14.4	71	80	90	100	112	132	2870	2870	8360	9610	1890
	301 R2	14.8	61	1090	7.4	14.4	71	80	90	100	112	132	3090	3090	8940	10300	2030
	301 R2	18.5	49	660	3.6	14.4	71	80	90	100	112	132	3330	3330	9560	11000	2190
	301 R3	24.8	36	1300	5.4	14.4	71	80	90	100	112	132	3680	3680	10400	12000	2420
	301 R3	30.4	29.6	1460	4.9	14.4	71	80	90	100	112	132	3930	3930	11100	12800	2590
	301 R3	37.3	24.2	1500	4.2	14.4	71	80	90	100	112	132	4210	4210	11800	13600	2770
	301 R3	41.2	21.9	1300	3.3	14.4	71	80	90	100	112	132	4350	4350	12200	14000	2860
	301 R3	50.4	17.9	1560	3.2	14.4	71	80	90	100	112	132	4660	4660	12900	14800	3060
	301 R3	62.9	14.3	1620	2.7	14.4	71	80	90	100	112	132	5010	5010	13800	15900	3300
	301 R3	68.2	13.2	1300	2.0	14.4	71	80	90	100	112	132	5150	5150	14200	16300	3390
	301 R3	78.7	11.4	1570	2.1	14.4	71	80	90	100	112	132	5400	5400	14800	17000	3550
	301 R3	85.2	10.6	1300	1.6	14.4	71	80	90	100	112	132	5540	5540	15100	17400	3650
	301 R3	107	8.5	1300	1.3	14.4	71	80	90	100	112	132	5970	5970	16200	18600	3930
	301 R3	133	6.8	1150	0.89	14.4	71	80	90	100	112	132	6430	6430	17300	19900	4230
	301 R4	106	8.5	1710	1.7	12.0	71	80	90	100	112	132	5960	5960	16100	18500	3920
	301 R4	130	6.9	1730	1.4	12.0	71	80	90	100	112	132	6380	6380	17200	19700	4190
	301 R4	143	6.3	1300	0.97	12.0	71	80	90	100	112	132	6590	6590	17700	20300	4340
	301 R4	159	5.7	1740	1.2	12.0	71	80	90	100	112	132	6830	6830	18200	20900	4490
301 R4	175	5.1	1750	1.1	12.0	71	80	90	100	112	132	7060	7060	18800	21600	4640	
301 R4	215	4.2	1810	0.90	12.0	71	80	90	100	112	132	7550	7550	20000	22900	4960	
301 R4	237	3.8	1360	0.61	12.0	71	80	90	100	112	132	7800	7800	20600	23600	5130	
301 R4	268	3.4	1890	0.75	12.0	71	80	90	100	112	132	8130	8130	21300	24500	5340	
301 R4	291	3.1	1920	0.70	12.0	71	80	90	100	112	132	8350	8350	21900	25100	5490	
301 R4	363	2.5	2000	0.59	12.0	71	80	90	100	112	132	8990	8990	23400	26800	5910	
301 R4	394	2.3	1470	0.40	12.0	71	80	90	100	112	132	9240	9240	23900	27500	6070	
301 R4	453	2.0	2000	0.47	12.0	71	80	90	100	112	132	9680	9680	25000	28700	6360	
301 R4	491	1.8	1530	0.33	12.0	71	80	90	100	112	132	9940	9940	25600	29400	6540	
301 R4	613	1.5	1590	0.28	12.0	71	80	90	100	112	132	10700	10700	27300	31400	7040	
301 R4	766	1.2	1650	0.23	12.0	71	80	90	100	112	132	11500	11500	29200	33600	7580	

EQ303R							2500 Nm										
n <sub>1</sub> min <sup>-1</sup>	i	n <sub>2</sub> min <sup>-1</sup>	m <sub>n2</sub> Nm	P <sub>n1</sub> kW	Pt kW	IEC	R <sub>n2</sub> [N]										
							MC	MZ	HC/PC	HZ/PZ	FZ						
1400	303 R2	9.23	152	1410	24	18.0	71	80	90	100	112	132	7010	8100	13900	16700	4500
	303 R2	10.9	129	1620	23	18.0	71	80	90	100	112	132	7410	8560	14600	17600	4760
	303 R2	13.7	102	1690	19.2	18.0	71	80	90	100	112	132	8000	9230	15600	18800	5130
	303 R2	15.9	88	1460	14.3	18.0	71	80	90	100	112	132	8410	9710	16300	19700	5390
	303 R2	19.2	73	1570	12.7	18.0	71	80	90	100	112	132	8960	10300	17300	20800	5750
	303 R2	24.8	57	860	5.4	18.0	71	80	90	100	112	132	9750	11300	18700	22500	6250
	303 R3	25.7	55	1800	11.3	14.0	71	80	90	100	112	132	9870	11400	18900	22700	6330
	303 R3	31.5	45	1820	9.3	14.0	71	80	90	100	112	132	10600	12200	20100	24100	6770
	303 R3	37.1	38	2090	9.1	14.0	71	80	90	100	112	132	11200	12900	21100	25400	7160
	303 R3	42.6	33	1800	6.8	14.0	71	80	90	100	112	132	11700	13500	22000	26400	7490
	303 R3	46.6	30	2130	7.3	14.0	71	80	90	100	112	132	12000	13900	22600	27200	7720
	303 R3	50.3	27.9	2130	6.8	14.0	71	80	90	100	112	132	12300	14200	23100	27800	7920
	303 R3	54.2	25.8	1770	5.2	14.0	71	80	90	100	112	132	12700	14600	23600	28400	8120
	303 R3	63.1	22.2	2150	5.5	14.0	71	80	90	100	112	132	13300	15400	24700	29700	8540
	303 R3	73.3	19.1	1780	3.9	14.0	71	80	90	100	112	132	14000	16200	25900	31100	8980

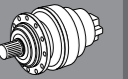
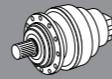

EQ303R								2500 Nm						
n <sub>1</sub> min <sup>-1</sup>		i	n <sub>2</sub> min <sup>-1</sup>	m <sub>n2</sub> Nm	P <sub>n1</sub> kW	Pt kW	IEC	R <sub>n2</sub> [N]						
								MC	MZ	HC/PC	HZ/PZ	FZ		
900	303 R4	336	2.7	2420	0.77	14.4	71 80 90 100 112 132	26900	31100	46600	56000	17300		
	303 R4	364	2.5	2450	0.72	14.4	71 80 90 100 112 132	27700	31900	47700	57400	17700		
	303 R4	390	2.3	2020	0.55	14.4	71 80 90 100 112 132	28300	32700	48700	58600	18200		
	303 R4	452	2.0	2250	0.53	14.4	71 80 90 100 112 132	29700	34300	50900	61300	19100		
	303 R4	528	1.7	2120	0.43	14.4	71 80 90 100 112 132	31300	36200	53400	64200	20100		
	303 R4	567	1.6	2640	0.50	14.4	71 80 90 100 112 132	32100	37000	54500	65600	20600		
	303 R4	659	1.4	2190	0.35	14.4	71 80 90 100 112 132	33700	38900	57000	68600	21600		
	303 R4	797	1.1	1960	0.26	14.4	71 80 90 100 112 132	35900	41500	60400	72700	23000		
	303 R4	824	1.1	2270	0.29	14.4	71 80 90 100 112 132	36000	41900	61000	73400	23300		

EQ304R								3600 Nm						
n <sub>1</sub> min <sup>-1</sup>		i	n <sub>2</sub> min <sup>-1</sup>	m <sub>n2</sub> Nm	P <sub>n1</sub> kW	Pt kW	IEC	R <sub>n2</sub> [N]						
								MC	MZ	HC/PC	HZ/PZ	FZ		
1400	304 R2	9.23	152	1470	25	18.0	71 80 90 100 112 132	7010	8100	13900	16700	4500		
	304 R2	10.9	129	1730	25	18.0	71 80 90 100 112 132	7410	8560	14600	17600	4760		
	304 R2	13.7	102	2170	25	18.0	71 80 90 100 112 132	8000	9230	15600	18800	5130		
	304 R2	16.8	83	2210	20	18.0	71 80 90 100 112 132	8570	9900	16600	20000	5500		
	304 R3	25.7	55	2400	15.0	14.0	71 80 90 100 112 132	9870	11400	18900	22700	6330		
	304 R3	31.5	44	2940	15.0	14.0	71 80 90 100 112 132	10600	12200	20100	24100	6770		
	304 R3	37.1	38	3150	13.6	14.0	71 80 90 100 112 132	11200	12900	21100	25400	7160		
	304 R3	42.6	33	3200	12.1	14.0	71 80 90 100 112 132	11700	13500	22000	26400	7490		
	304 R3	46.6	30	2770	9.5	14.0	71 80 90 100 112 132	12000	13900	22600	27200	7720		
	304 R3	50.3	27.9	3230	10.3	14.0	71 80 90 100 112 132	12300	14200	23100	27800	7920		
304 R3	63.1	22.2	2780	7.1	14.0	71 80 90 100 112 132	13300	15400	24700	29700	8540			
304 R3	78.7	17.8	2780	5.7	14.0	71 80 90 100 112 132	14300	16500	26400	31800	9190			
304 R3	97.0	14.4	2290	3.8	14.0	71 80 90 100 112 132	15400	17700	28100	33800	9860			
304 R3	121	11.5	2290	3.0	14.0	71 80 90 100 112 132	16600	19100	30100	36200	10600			
304 R4	89.4	15.7	3350	6.2	12.0	71 80 90 100 112 132	15000	17300	27400	33000	9590			
304 R4	109	12.8	3390	5.1	12.0	71 80 90 100 112 132	16000	18500	29200	35100	10300			
304 R4	129	10.8	3520	4.5	12.0	71 80 90 100 112 132	16900	19500	30600	36900	10800			
304 R4	148	9.4	3440	3.8	12.0	71 80 90 100 112 132	17700	20400	31900	38400	11400			
304 R4	158	8.8	3560	3.7	12.0	71 80 90 100 112 132	18100	20900	32600	39200	11600			
304 R4	185	7.6	3460	3.1	12.0	71 80 90 100 112 132	19100	22000	34100	41100	12200			
304 R4	214	6.5	3610	2.8	12.0	71 80 90 100 112 132	20000	23100	35700	42900	12800			
304 R4	227	6.2	3480	2.5	12.0	71 80 90 100 112 132	20400	23500	36300	43600	13100			
304 R4	267	5.2	3640	2.3	12.0	71 80 90 100 112 132	21500	24900	38100	45900	13800			
304 R4	290	4.8	3650	2.1	12.0	71 80 90 100 112 132	22100	25600	39100	47000	14200			
304 R4	307	4.6	3500	1.9	12.0	71 80 90 100 112 132	22500	26000	39700	47800	14500			
304 R4	338	4.1	2320	1.1	12.0	71 80 90 100 112 132	23300	26900	40900	49200	14900			
304 R4	364	3.8	2900	1.3	12.0	71 80 90 100 112 132	23900	27600	41800	50300	15300			
304 R4	414	3.4	2350	0.94	12.0	71 80 90 100 112 132	24900	28800	43400	52300	16000			
304 R4	452	3.1	3690	1.4	12.0	71 80 90 100 112 132	25700	29600	44600	53700	16500			
304 R4	560	2.5	2400	0.71	12.0	71 80 90 100 112 132	27600	31800	47600	57200	17700			
304 R4	699	2.0	2480	0.59	12.0	71 80 90 100 112 132	29700	34300	50900	61200	19000			
900	304 R2	9.23	98	1680	18.3	22	71 80 90 100 112 132	8130	9380	15800	19100	5210		
	304 R2	10.9	83	1980	18.2	22	71 80 90 100 112 132	8590	9920	16700	20000	5510		
	304 R2	13.7	66	2480	18.2	22	71 80 90 100 112 132	9260	10700	17800	21500	5940		
	304 R2	16.8	53	2280	13.6	22	71 80 90 100 112 132	9930	11500	19000	22800	6370		
	304 R3	25.7	35	2710	10.9	16.8	71 80 90 100 112 132	11400	13200	21500	25900	7330		
	304 R3	31.5	28.6	3080	10.1	16.8	71 80 90 100 112 132	12200	14100	22900	27600	7850		
	304 R3	37.1	24.2	3270	9.1	16.8	71 80 90 100 112 132	12900	14900	24100	29000	8290		
	304 R3	42.6	21.1	3290	8.0	16.8	71 80 90 100 112 132	13500	15600	25100	30200	8680		
	304 R3	46.6	19.3	2780	6.2	16.8	71 80 90 100 112 132	13900	16100	25800	31000	8950		
	304 R3	50.3	17.9	3360	6.9	16.8	71 80 90 100 112 132	14300	16500	26400	31700	9170		
304 R3	63.1	14.3	2790	4.6	16.8	71 80 90 100 112 132	15400	17800	28200	33900	9900			
304 R3	78.7	11.4	2800	3.7	16.8	71 80 90 100 112 132	16600	19200	30200	36300	10700			
304 R3	97.0	9.3	2290	2.4	16.8	71 80 90 100 112 132	17800	20600	32100	38600	11400			
304 R3	121	7.4	2290	2.0	16.8	71 80 90 100 112 132	19200	22100	34300	41300	12300			

EQ304R								3600 Nm						
n <sub>1</sub> min <sup>-1</sup>		i	n <sub>2</sub> min <sup>-1</sup>	m <sub>n2</sub> Nm	P <sub>n1</sub> kW	Pt kW	IEC	R <sub>n2</sub> [N]						
								MC	MZ	HC/PC	HZ/PZ	FZ		
900	304 R4	89.4	10.1	3440	4.1	14.4	71 80 90 100 112 132	17300	20000	31300	37700	11100		
	304 R4	109	8.2	3460	3.4	14.4	71 80 90 100 112 132	18500	21400	33300	40100	11900		
	304 R4	129	7.0	3600	3.0	14.4	71 80 90 100 112 132	19600	22600	35000	42100	12600		
	304 R4	148	6.1	3480	2.5	14.4	71 80 90 100 112 132	20500	23700	36500	43900	13200		
	304 R4	158	5.7	3630	2.4	14.4	71 80 90 100 112 132	21000	24200	37200	44700	13400		
	304 R4	185	4.9	3500	2.0	14.4	71 80 90 100 112 132	22100	25500	39000	46900	14200		
	304 R4	214	4.2	3670	1.8	14.4	71 80 90 100 112 132	23200	26800	40700	49000	14900		
	304 R4	227	4.0	3510	1.6	14.4	71 80 90 100 112 132	23600	27300	41400	49800	15200		
	304 R4	267	3.4	3680	1.5	14.4	71 80 90 100 112 132	25000	28800	43500	52400	16000		
	304 R4	290	3.1	3690	1.4	14.4	71 80 90 100 112 132	25600	29600	44600	53600	16500		
	304 R4	307	2.9	3520	1.2	14.4	71 80 90 100 112 132	26100	30200	45300	54500	16800		
	304 R4	338	2.7	2390	0.75	14.4	71 80 90 100 112 132	27000	31100	46700	56100	17300		
	304 R4	364	2.5	3080	0.90	14.4	71 80 90 100 112 132	27700	31900	47700	57400	17700		
	304 R4	414	2.2	2450	0.63	14.4	71 80 90 100 112 132	28900	33300	49600	59700	18500		
	304 R4	452	2.0	3770	0.89	14.4	71 80 90 100 112 132	29700	34300	50900	61300	19100		
	304 R4	560	1.6	2560	0.49	14.4	71 80 90 100 112 132	31900	36900	54300	65300	20500		
	304 R4	699	1.3	2650	0.40	14.4	71 80 90 100 112 132	34400	39700	58100	69900	22100		

EQ305R								5000 Nm						
n <sub>1</sub> min <sup>-1</sup>		i	n <sub>2</sub> min <sup>-1</sup>	m <sub>n2</sub> Nm	P <sub>n1</sub> kW	Pt kW	IEC	R <sub>n2</sub> [N]						
								MC	MZ	HC/PC	HZ/PZ	FZ		
1400	305 R2	9.23	152	1410	24	18.0	71 80 90 100 112 132	7010	8100	13900	16700	4500		
	305 R2	10.9	129	1670	24	18.0	71 80 90 100 112 132	7410	8560	14600	17600	4760		
	305 R2	13.7	102	2080	24	18.0	71 80 90 100 112 132	8000	9230	15600	18800	5130		
	305 R2													

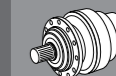
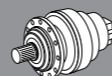

EQ305R							5000 Nm						
n <sub>1</sub> min <sup>-1</sup>		i	n <sub>2</sub> min <sup>-1</sup>	m <sub>n2</sub> Nm	P <sub>n1</sub> kW	Pt kW	IEC	R <sub>n2</sub> [N]					
								MC	MZ	HC/PC	HZ/PZ	FZ	
900	305 R2	9.23	98	1610	17.5	22	71 80 90 100 112 132	8130	9380	15800	19100	5210	
	305 R2	10.9	83	1900	17.5	22	71 80 90 100 112 132	8590	9920	16700	20000	5510	
	305 R2	13.7	66	2390	17.5	22	71 80 90 100 112 132	9260	10700	17800	21500	5940	
	305 R2	15.9	57	2790	17.6	22	71 80 90 100 112 132	9740	11200	18700	22400	6250	
	305 R2	19.2	47	3000	15.7	22	71 80 90 100 112 132	10400	12000	19800	23800	6660	
	305 R3	25.7	35	2880	11.6	16.8	71 80 90 100 112 132	11400	13200	21500	25900	7330	
	305 R3	31.5	28.6	3370	11.1	16.8	71 80 90 100 112 132	12200	14100	22900	27600	7850	
	305 R3	37.1	24.2	4120	11.4	16.8	71 80 90 100 112 132	12900	14900	24100	29000	8290	
	305 R3	42.6	21.1	3650	8.8	16.8	71 80 90 100 112 132	13500	15600	25100	30200	8680	
	305 R3	46.6	19.3	4050	9.0	16.8	71 80 90 100 112 132	13900	16100	25800	31000	8950	
	305 R3	50.3	17.9	4480	9.2	16.8	71 80 90 100 112 132	14300	16500	26400	31700	9170	
	305 R3	54.2	16.6	3580	6.8	16.8	71 80 90 100 112 132	14700	16900	27000	32400	9410	
	305 R3	63.1	14.3	4210	6.9	16.8	71 80 90 100 112 132	15400	17800	28200	33900	9900	
	305 R3	73.3	12.3	3590	5.1	16.8	71 80 90 100 112 132	16200	18700	29500	35500	10400	
	305 R3	78.7	11.4	4330	5.7	16.8	71 80 90 100 112 132	16600	19200	30200	36300	10700	
	305 R3	91.5	9.8	3600	4.1	16.8	71 80 90 100 112 132	17500	20200	31500	38000	11200	
305 R3	114	7.9	3600	3.2	16.8	71 80 90 100 112 132	18800	21700	33700	40600	12100		
305 R4	129	7.0	5250	4.3	14.4	71 80 90 100 112 132	19600	22600	35000	42100	12600		
305 R4	148	6.1	4270	3.1	14.4	71 80 90 100 112 132	20500	23700	36500	43900	13200		
305 R4	158	5.7	5280	3.6	14.4	71 80 90 100 112 132	21000	24200	37200	44700	13400		
305 R4	185	4.9	4310	2.5	14.4	71 80 90 100 112 132	22100	25500	39000	46900	14200		
305 R4	214	4.2	5350	2.7	14.4	71 80 90 100 112 132	23200	26800	40700	49000	14900		
305 R4	231	3.9	3720	1.7	14.4	71 80 90 100 112 132	23800	27400	41600	50100	15300		
305 R4	255	3.5	3770	1.6	14.4	71 80 90 100 112 132	24600	28400	42900	51600	15800		
305 R4	290	3.1	5370	2.0	14.4	71 80 90 100 112 132	25600	29600	44600	53600	16500		
305 R4	313	2.9	3880	1.3	14.4	71 80 90 100 112 132	26300	30400	45600	54900	16900		
305 R4	336	2.7	4850	1.5	14.4	71 80 90 100 112 132	26900	31100	46600	56000	17300		
305 R4	364	2.5	4910	1.4	14.4	71 80 90 100 112 132	27700	31900	47700	57400	17700		
305 R4	390	2.3	4000	1.1	14.4	71 80 90 100 112 132	28300	32700	48700	58600	18200		
305 R4	452	2.0	4750	1.1	14.4	71 80 90 100 112 132	29700	34300	50900	61300	19100		
305 R4	528	1.7	4210	0.85	14.4	71 80 90 100 112 132	31300	36200	53400	64200	20100		
305 R4	567	1.6	5240	0.98	14.4	71 80 90 100 112 132	32100	37000	54500	65600	20600		
305 R4	659	1.4	4370	0.71	14.4	71 80 90 100 112 132	33700	38900	57000	68600	21600		
305 R4	797	1.1	3730	0.50	14.4	71 80 90 100 112 132	35900	41500	60400	72700	23000		
305 R4	824	1.1	4530	0.59	14.4	71 80 90 100 112 132	36000	41900	61000	73400	23300		

EQ306R							8000 Nm						
n <sub>1</sub> min <sup>-1</sup>		i	n <sub>2</sub> min <sup>-1</sup>	m <sub>n2</sub> Nm	P <sub>n1</sub> kW	Pt kW	IEC	R <sub>n2</sub> [N]					
								MC	MZ	HC/PC	HZ/PZ	FZ	
1400	306 R2	9.23	152	1410	24	18.0	71 80 90 100 112 132	8730	9900	22700	26400	6560	
	306 R2	10.9	129	1670	24	18.0	71 80 90 100 112 132	10500	10500	23900	27800	6930	
	306 R2	13.7	102	2080	24	18.0	71 80 90 100 112 132	11200	11300	25500	29700	7480	
	306 R2	15.9	88	2440	24	18.0	71 80 90 100 112 132	9230	11900	26700	31100	7870	
	306 R2	19.2	73	2960	24	18.0	71 80 90 100 112 132	9960	12600	28300	33000	8380	
	306 R3	33.2	42	4920	24	14.0	71 80 90 100 112 132	13400	15200	33300	38800	10100	
	306 R3	39.2	36	5530	23	14.0	71 80 90 100 112 132	14100	16000	35000	40800	10600	
	306 R3	46.3	30	6720	23	14.0	71 80 90 100 112 132	15000	16900	36800	42900	11200	
	306 R3	58.1	24.1	7050	19.5	14.0	71 80 90 100 112 132	16100	18300	39400	45900	12100	
	306 R3	67.5	20.7	5970	14.2	14.0	71 80 90 100 112 132	17000	19200	41300	48000	12700	
	306 R3	72.9	19.2	6870	15.1	14.0	71 80 90 100 112 132	17400	19700	42200	49200	13100	
	306 R3	84.7	16.5	6950	13.2	14.0	71 80 90 100 112 132	18300	20700	44200	51400	13700	
	306 R3	98.5	14.2	6320	10.3	14.0	71 80 90 100 112 132	19200	21800	46200	53800	14400	
	306 R3	119	11.7	6420	8.6	14.0	71 80 90 100 112 132	20500	23200	48900	57000	15400	
	306 R3	144	9.7	5500	6.1	14.0	71 80 90 100 112 132	21800	24700	51800	60300	16400	

EQ306R							8000 Nm						
n <sub>1</sub> min <sup>-1</sup>		i	n <sub>2</sub> min <sup>-1</sup>	m <sub>n2</sub> Nm	P <sub>n1</sub> kW	Pt kW	IEC	R <sub>n2</sub> [N]					
								MC	MZ	HC/PC	HZ/PZ	FZ	
1400	306 R4	158	8.9	8900	9.3	12.0	71 80 90 100 112 132	22500	25500	53200	62000	16900	
	306 R4	168	8.3	7550	7.5	12.0	71 80 90 100 112 132	23000	26000	54200	63100	17300	
	306 R4	181	7.7	7860	7.2	12.0	71 80 90 100 112 132	23600	26700	55500	64600	17700	
	306 R4	214	6.6	8950	6.9	12.0	71 80 90 100 112 132	24900	28200	58300	67900	18700	
	306 R4	230	6.1	7400	5.3	12.0	71 80 90 100 112 132	25500	28900	59600	69400	19200	
	306 R4	249	5.6	7800	5.2	12.0	71 80 90 100 112 132	26200	29700	61000	71000	19700	
	306 R4	289	4.8	7830	4.5	12.0	71 80 90 100 112 132	27500	31200	63800	74300	20700	
	306 R4	312	4.5	7400	3.9	12.0	71 80 90 100 112 132	28200	32000	65300	76000	21200	
	306 R4	389	3.6	6820	2.9	12.0	71 80 90 100 112 132	30400	34400	69800	81200	22800	
	306 R4	420	3.3	8200	3.2	12.0	71 80 90 100 112 132	31200	35300	71400	83100	23400	
	306 R4	455	3.1	6980	2.5	12.0	71 80 90 100 112 132	32000	36300	73100	85100	24100	
	306 R4	488	2.9	8360	2.8	12.0	71 80 90 100 112 132	32800	37100	74700	87000	24600	
	306 R4	550	2.5	7180	2.2	12.0	71 80 90 100 112 132	34100	38700	77400	90100	25600	
	306 R4	590	2.4	8550	2.4	12.0	71 80 90 100 112 132	34900	39600	79100	92100	26200	
	306 R4	665	2.1	6090	1.5	12.0	71 80 90 100 112 132	36400	41200	82000	95400	27300	
	306 R4	830	1.7	6350	1.3	12.0	71 80 90 100 112 132	39100	44300	87600	102000	29400	
900	306 R2	9.23	98	1610	17.5	22	71 80 90 100 112 132	10100	11500	25900	30200	7600	
	306 R2	10.9	83	1900	17.5	22	71 80 90 100 112 132	10700	12100	27200	31700	8040	
	306 R2	13.7	66	2390	17.5	22	71 80 90 100 112 132	11500	13100	29200	34000	8670	
	306 R2	15.9	57	2790	17.6	22	71 80 90 100 112 132	12100	13700	30500	35500	9110	
	306 R2	19.2	47	3370	17.5	22	71 80 90 100 112 132	12900	14600	32300	37600	9710	
	306 R3	33.2	27.1	5560	17.3	16.8	71 80 90 100 112 132	15500	17600	38100	44300	11700	
	306 R3	39.2	23.0	6150	16.2	16.8	71 80 90 100 112 132	16400	18600	40000	46600	12300	
	306 R3	46.3	19.4	7650	17.1	16.8	71 80 90 100 112 132	17300	19600	42100	49000	13000	
	306 R3	58.1	15.5	8010	14.2	16.8	71 80 90 100 112 132	18700	21200	45000	52400	14000	
	306 R3	67.5	13.3	6800	10.4	16.8	71 80 90 100 112 132	19600	22300	47100	54900	14800	
	306 R3	72.9	12.3	7490	10.6	16.8	71 80 90 100 112 132	20200	22800	48200	56100	15100	
	306 R3	84.7	10.6	7690	9.4	16.8	71 80 90 100 112 132	21200	24000	50400	58700	15900	
	306 R3	98.5	9.1	6500	6.8	16.8	71 80 90 100 112 132	22300	25200	52800	61400	16700	
	306 R3	119	7.6	6500	5.6	16.8	71 80 90 100 112 132	23700	26900	55900	65000	17800	
	306 R3	144	6.2	5500	3.9	16.8	71 80 90 100 112 132	25300	28700	59100	68900	19000	
	306 R4	158	5.7	9280	6.3	14.4	71 80 90 100 112 132	26100	29500	60800	70800	19600	
	306 R4	168	5.4	7680	4.9	14.4	71 80 90 100 112 132	26600	30200	61900	72100	20000	
	306 R4	181	5.0	8700	5.1	14.4	71 80 90 100 112 132	27300	30900	63300	73700	20500	
	306 R4	214	4.2	9450	4.7	14.4	71 80 90 100						

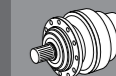
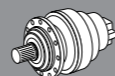

EQ307R								12500 Nm				
$n_1$ min <sup>-1</sup>		i	$n_2$ min <sup>-1</sup>	$m_{n2}$ Nm	$P_{n1}$ kW	Pt kW	P(IEC)	$R_{n2}$ [N]				
								MC	MZ	HC/PC	HZ/PZ	FZ
1400	307 R3	31.6	44	4720	24	22	71 80 90 100 112 132 160 - -	14600	18400	35400	46300	12700
	307 R3	37.7	37	5580	24	22	71 80 90 100 112 132 160 - -	15500	19500	37300	48800	13500
	307 R3	44.6	31	6670	24	22	71 80 90 100 112 132 160 - -	16400	20600	39200	51300	14300
	307 R3	55.9	25.0	8360	24	22	71 80 90 100 112 132 160 - -	17700	22200	41900	55000	15400
	307 R3	65.0	21.5	9670	24	22	71 80 90 100 112 132 160 - -	18600	23300	43900	57500	16200
	307 R3	71.8	19.5	9230	21	22	71 80 90 100 112 132 160 - -	19200	24100	45200	59200	16700
	307 R3	78.6	17.8	10400	21	22	71 80 90 100 112 132 160 - -	19800	24900	46500	60900	17200
	307 R3	83.4	16.8	9500	18.3	22	71 80 90 100 112 132 160 - -	20200	25400	47300	62000	17600
	307 R3	99.0	14.1	8470	13.8	22	71 80 90 100 112 132 160 - -	21400	26900	49800	65200	18600
	307 R3	120	11.7	8600	11.5	22	71 80 90 100 112 132 160 - -	22800	28600	52700	69100	19800
	307 R4	152	9.2	12500	13.7	15.0	71 80 90 100 112 132 160 - -	24700	31000	56600	74200	21500
	307 R4	165	8.5	10500	10.6	15.0	71 80 90 100 112 132 160 - -	25400	31900	58000	76100	22100
	307 R4	191	7.3	12700	11.0	15.0	71 80 90 100 112 132 160 - -	26600	33400	60600	79400	23200
	307 R4	206	6.8	12700	10.2	15.0	71 80 90 100 112 132 160 - -	27300	34300	62000	81200	23700
	307 R4	232	6.0	10600	7.6	15.0	71 80 90 100 112 132 160 - -	28400	35700	64300	84200	24700
	307 R4	258	5.4	12900	8.2	15.0	71 80 90 100 112 132 160 - -	29500	37000	66400	87000	25600
	307 R4	284	4.9	10700	6.2	15.0	71 80 90 100 112 132 160 - -	30400	38200	68300	89500	26500
	307 R4	300	4.7	13000	7.2	15.0	71 80 90 100 112 132 160 - -	31000	38900	69400	91000	26900
	307 R4	331	4.2	11000	5.5	15.0	71 80 90 100 112 132 160 - -	32000	40200	71500	93700	27800
	307 R4	363	3.9	12300	5.6	15.0	71 80 90 100 112 132 160 - -	33000	41400	73500	96300	28700
307 R4	413	3.4	11400	4.6	15.0	71 80 90 100 112 132 160 - -	34500	43200	76400	100100	30000	
307 R4	453	3.1	13500	4.9	15.0	71 80 90 100 112 132 160 - -	35500	44600	78600	102900	30900	
307 R4	490	2.9	9420	3.2	15.0	71 80 90 100 112 132 160 - -	36500	45800	80500	105400	31700	
307 R4	581	2.4	12100	3.4	15.0	71 80 90 100 112 132 160 - -	38600	48500	84700	110900	33600	
307 R4	690	2.0	9900	2.4	15.0	71 80 90 100 112 132 160 - -	40900	51300	89100	116800	35500	
900	307 R2	13.0	69	4770	37	42	- - - - - 132 160 180 200	12600	15800	30900	40500	10900
	307 R2	15.5	58	5650	37	42	- - - - - 132 160 180 200	13400	16800	32600	42700	11600
	307 R2	19.8	45	7230	37	42	- - - - - 132 160 180 200	14500	18200	35100	46000	12600
	307 R2	23.5	38	7860	33	42	- - - - - 132 160 180 200	15400	19300	36900	48400	13400
	307 R3	31.6	28.5	5390	17.6	26	71 80 90 100 112 132 160 - -	17000	21300	40400	52900	14700
	307 R3	37.7	23.8	6380	17.5	26	71 80 90 100 112 132 160 - -	18000	22600	42600	55800	15600
	307 R3	44.6	20.2	7610	17.6	26	71 80 90 100 112 132 160 - -	19000	23800	44700	58600	16500
	307 R3	55.9	16.1	9540	17.6	26	71 80 90 100 112 132 160 - -	20500	25700	47900	62700	17800
	307 R3	65.0	13.8	11100	17.6	26	71 80 90 100 112 132 160 - -	21600	27000	50100	65600	18700
	307 R3	71.8	12.5	10100	14.5	26	71 80 90 100 112 132 160 - -	22300	28000	51600	67600	19400
	307 R3	78.6	11.4	11800	15.5	26	71 80 90 100 112 132 160 - -	23000	28800	53000	69500	20000
	307 R3	83.4	10.8	10300	12.8	26	71 80 90 100 112 132 160 - -	23400	29400	54000	70700	20400
	307 R3	99.0	9.1	8700	9.1	26	71 80 90 100 112 132 160 - -	24800	31100	56800	74500	21600
	307 R3	120	7.5	8700	7.5	26	71 80 90 100 112 132 160 - -	26400	33200	60200	78900	23000
	307 R4	152	5.9	12800	9.0	18.0	71 80 90 100 112 132 160 - -	28600	35900	64600	84700	24900
	307 R4	165	5.4	10700	6.9	18.0	71 80 90 100 112 132 160 - -	29400	36900	66300	86800	25600
	307 R4	191	4.7	13000	7.2	18.0	71 80 90 100 112 132 160 - -	30900	38700	69200	90700	26800
	307 R4	206	4.4	13100	6.8	18.0	71 80 90 100 112 132 160 - -	31600	39700	70800	92700	27500
	307 R4	232	3.9	11200	5.1	18.0	71 80 90 100 112 132 160 - -	33000	41400	73400	96200	28600
	307 R4	258	3.5	13400	5.5	18.0	71 80 90 100 112 132 160 - -	34100	42800	75800	99300	29700
307 R4	284	3.2	11500	4.3	18.0	71 80 90 100 112 132 160 - -	35300	44200	78000	102200	30700	
307 R4	300	3.0	13600	4.8	18.0	71 80 90 100 112 132 160 - -	35900	45000	79300	103900	31200	
307 R4	331	2.7	11800	3.8	18.0	71 80 90 100 112 132 160 - -	37100	46500	81600	107000	32200	
307 R4	363	2.5	12300	3.6	18.0	71 80 90 100 112 132 160 - -	38200	48000	83900	110000	33200	
307 R4	413	2.2	12300	3.2	18.0	71 80 90 100 112 132 160 - -	39900	50100	87300	114300	34700	
307 R4	453	2.0	14100	3.3	18.0	71 80 90 100 112 132 160 - -	41200	51700	89700	117500	35800	
307 R4	490	1.8	10100	2.2	18.0	71 80 90 100 112 132 160 - -	42300	53100	91900	120400	36800	
307 R4	581	1.5	13000	2.4	18.0	71 80 90 100 112 132 160 - -	44700	56100	96700	126700	38900	
307 R4	690	1.3	10600	1.6	18.0	71 80 90 100 112 132 160 - -	47400	59400	101800	133300	41200	

EQ309R								18000 Nm				
$n_1$ min <sup>-1</sup>		i	$n_2$ min <sup>-1</sup>	$m_{n2}$ Nm	$P_{n1}$ kW	Pt kW	P(IEC)	$R_{n2}$ [N]				
								MC	MZ	HC/PC	HZ/PZ	FZ
1400	309 R2	13.0	108	4200	51	35	- - - - - 132 160 180 200	-	-	27500	35400	7560
	309 R2	15.5	91	4940	50	35	- - - - - 132 160 180 200	-	-	29000	37400	8020
	309 R2	19.8	71	6370	50	35	- - - - - 132 160 180 200	-	-	31200	40300	8710
	309 R2	23.5	59	7590	50	35	- - - - - 132 160 180 200	-	-	32900	42400	9220
	309 R3	31.6	44	4720	24	22	71 80 90 100 112 132 160 - -	-	-	35900	46300	10200
	309 R3	37.7	37	5580	24	22	71 80 90 100 112 132 160 - -	-	-	37900	48800	10800
	309 R3	44.6	31	6670	24	22	71 80 90 100 112 132 160 - -	-	-	39800	51300	11400
	309 R3	55.9	25.0	8360	24	22	71 80 90 100 112 132 160 - -	-	-	42600	55000	12300
	309 R3	65.0	21.5	9670	24	22	71 80 90 100 112 132 160 - -	-	-	44600	57500	12900
	309 R3	71.8	19.5	10700	24	22	71 80 90 100 112 132 160 - -	-	-	45900	59200	13400
	309 R3	83.4	16.8	12400	24	22	71 80 90 100 112 132 160 - -	-	-	48000	62000	14100
	309 R3	99.0	14.1	12300	20	22	71 80 90 100 112 132 160 - -	-	-	50600	65200	14900
	309 R3	120	11.7	12700	17.1	22	71 80 90 100 112 132 160 - -	-	-	53600	69100	15900
	309 R4	152	9.2	13800	15.0	15.0	71 80 90 100 112 132 160 - -	-	-	57500	74200	17200
	309 R4	165	8.5	15000	15.0	15.0	71 80 90 100 112 132 160 - -	-	-	59000	76100	17700
	309 R4	191	7.3	16200	14.1	15.0	71 80 90 100 112 132 160 - -	-	-	61600	79400	18500
	309 R4	206	6.8	16400	13.2	15.0	71 80 90 100 112 132 160 - -	-	-	63000	81200	19000
	309 R4	232	6.0	16100	11.5	15.0	71 80 90 100 112 132 160 - -	-	-	65300	84200	19800
	309 R4	258	5.4	17200	11.0	15.0	71 80 90 100 112 132 160 - -	-	-	67400	87000	20500
	309 R4	285	4.9	16200	9.5	15.0	71 80 90 100 112 132 160 - -	-	-	69400	89500	21200
309 R4	331	4.2	16600	8.3	15.0	71 80 90 100 112 132 160 - -	-	-	72700	93700	22300	
309 R4	374	3.7	14300	6.3	15.0	71 80 90 100 112 132 160 - -	-	-	75400	97200	23200	
309 R4	413	3.4	17200	6.9	15.0	71 80 90 100 112 132 160 - -	-	-	77700	100100	24000	
309 R4	457	3.1	1400									

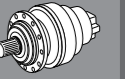
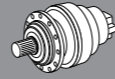

EQ310R							25000 Nm										
n <sub>1</sub> min <sup>-1</sup>	i	n <sub>2</sub> min <sup>-1</sup>	m <sub>n2</sub> Nm	P <sub>n1</sub> kW	Pt kW	P(IEC)	R <sub>n2</sub> [N]										
							MC	MZ	HC/PC	HZ/PZ	FZ						
1400	310 R2 (B)	12.0	117	10000	130	55	-	-	-	-	-	180	200	225	-		
	310 R2 (B)	15.4	91	10600	107	55	-	-	-	-	-	180	200	225	-		
	310 R2 (B)	18.3	77	11100	94	55	-	-	-	-	-	180	200	225	-		
	310 R2 (C)	16.6	84	10700	100	55	-	-	-	-	-	180	200	225	250		
	310 R2 (C)	21.3	66	11700	85	55	-	-	-	-	-	180	200	225	250		
	310 R2 (C)	25.3	55	12200	75	55	-	-	-	-	-	180	200	225	250		
	310 R3	37.7	37	5580	24	22	71	80	90	100	112	132	160	-	-	-	
	310 R3	44.6	31	6670	24	22	71	80	90	100	112	132	160	-	-	-	
	310 R3	55.9	25.0	8360	24	22	71	80	90	100	112	132	160	-	-	-	
	310 R3	65.0	21.5	9670	24	22	71	80	90	100	112	132	160	-	-	-	
	310 R3	71.8	19.5	10700	24	22	71	80	90	100	112	132	160	-	-	-	
	310 R3	78.6	17.8	11700	24	22	71	80	90	100	112	132	160	-	-	-	
	310 R3	83.4	16.8	12400	24	22	71	80	90	100	112	132	160	-	-	-	
	310 R3	99.0	14.1	14800	24	22	71	80	90	100	112	132	160	-	-	-	
	310 R3	120	11.7	17100	23	22	71	80	90	100	112	132	160	-	-	-	
	310 R4	136	10.3	19600	24	15.0	71	80	90	100	112	132	160	-	-	-	
	310 R4	160	8.7	22200	23	15.0	71	80	90	100	112	132	160	-	-	-	
	310 R4	189	7.4	23300	20	15.0	71	80	90	100	112	132	160	-	-	-	
310 R4	206	6.8	21700	17.5	15.0	71	80	90	100	112	132	160	-	-	-		
310 R4	234	6.0	20300	14.4	15.0	71	80	90	100	112	132	160	-	-	-		
310 R4	258	5.4	22400	14.4	15.0	71	80	90	100	112	132	160	-	-	-		
310 R4	283	4.9	22500	13.2	15.0	71	80	90	100	112	132	160	-	-	-		
310 R4	305	4.6	23000	12.5	15.0	71	80	90	100	112	132	160	-	-	-		
310 R4	334	4.2	25700	12.7	15.0	71	80	90	100	112	132	160	-	-	-		
310 R4	363	3.9	23700	10.8	15.0	71	80	90	100	112	132	160	-	-	-		
310 R4	419	3.3	28400	11.2	15.0	71	80	90	100	112	132	160	-	-	-		
310 R4	454	3.1	20200	7.4	15.0	71	80	90	100	112	132	160	-	-	-		
310 R4	517	2.7	25100	8.0	15.0	71	80	90	100	112	132	160	-	-	-		
310 R4	590	2.4	21800	6.1	15.0	71	80	90	100	112	132	160	-	-	-		
310 R4	639	2.2	21800	5.7	15.0	71	80	90	100	112	132	160	-	-	-		
310 R4	757	1.9	26200	5.7	15.0	71	80	90	100	112	132	160	-	-	-		
310 R4	898	1.6	23600	4.3	15.0	71	80	90	100	112	132	160	-	-	-		
900	310 R2 (B)	12.0	75	11600	97	66	-	-	-	-	-	-	-	180	200	225	-
	310 R2 (B)	15.4	58	12100	79	66	-	-	-	-	-	-	-	180	200	225	-
	310 R2 (B)	18.3	49	12600	69	66	-	-	-	-	-	-	-	180	200	225	-
	310 R2 (C)	16.6	54	12200	74	66	-	-	-	-	-	-	-	180	200	225	250
	310 R2 (C)	21.3	42	13400	63	99	-	-	-	-	-	-	-	180	200	225	250
	310 R2 (C)	25.3	36	13600	54	66	-	-	-	-	-	-	-	180	200	225	250
	310 R3	37.7	23.8	6380	17.5	26	71	80	90	100	112	132	160	-	-	-	-
	310 R3	44.6	20.2	7610	17.6	26	71	80	90	100	112	132	160	-	-	-	-
	310 R3	55.9	16.1	9540	17.6	26	71	80	90	100	112	132	160	-	-	-	-
	310 R3	65.0	13.8	11100	17.6	26	71	80	90	100	112	132	160	-	-	-	-
	310 R3	71.8	12.5	12200	17.6	26	71	80	90	100	112	132	160	-	-	-	-
	310 R3	78.6	11.4	13400	17.5	26	71	80	90	100	112	132	160	-	-	-	-
	310 R3	83.4	10.8	14200	17.6	26	71	80	90	100	112	132	160	-	-	-	-
	310 R3	99.0	9.1	16600	17.3	26	71	80	90	100	112	132	160	-	-	-	-
	310 R3	120	7.5	17900	15.5	26	71	80	90	100	112	132	160	-	-	-	-
	310 R4	136	6.6	22400	17.6	18.0	71	80	90	100	112	132	160	-	-	-	-
	310 R4	160	5.6	25300	16.8	18.0	71	80	90	100	112	132	160	-	-	-	-
	310 R4	189	4.8	26500	14.9	18.0	71	80	90	100	112	132	160	-	-	-	-
310 R4	206	4.4	23200	12.0	18.0	71	80	90	100	112	132	160	-	-	-	-	
310 R4	234	3.8	22700	10.3	18.0	71	80	90	100	112	132	160	-	-	-	-	
310 R4	258	3.5	24100	9.9	18.0	71	80	90	100	112	132	160	-	-	-	-	
310 R4	283	3.2	22800	8.6	18.0	71	80	90	100	112	132	160	-	-	-	-	
310 R4	305	3.0	24700	8.6	18.0	71	80	90	100	112	132	160	-	-	-	-	
310 R4	334	2.7	26800	8.5	18.0	71	80	90	100	112	132	160	-	-	-	-	
310 R4	363	2.5	25400	7.5	18.0	71	80	90	100	112	132	160	-	-	-	-	
310 R4	419	2.1	30000	7.6	18.0	71	80	90	100	112	132	160	-	-	-	-	
310 R4	454	2.0	22300	5.2	18.0	71	80	90	100	112	132	160	-	-	-	-	
310 R4	517	1.7	26900	5.5	18.0	71	80	90	100	112	132	160	-	-	-	-	
310 R4	590	1.5	21800	3.9	18.0	71	80	90	100	112	132	160	-	-	-	-	
310 R4	639	1.4	24100	4.0	18.0	71	80	90	100	112	132	160	-	-	-	-	
310 R4	757	1.2	27500	3.9	18.0	71	80	90	100	112	132	160	-	-	-	-	
310 R4	898	1.0	26000	3.1	18.0	71	80	90	100	112	132	160	-	-	-	-	

EQ311R							40000 Nm										
n <sub>1</sub> min <sup>-1</sup>	i	n <sub>2</sub> min <sup>-1</sup>	m <sub>n2</sub> Nm	P <sub>n1</sub> kW	Pt kW	P(IEC)	R <sub>n2</sub> [N]										
							MC	MZ	HC/PC	HZ/PZ	FZ						
1400	311 R2 (B)	12.0	117	11600	150	75	-	-	-	-	-	-	-	180	200	225	250
	311 R2 (B)	15.4	91	14800	150	75	-	-	-	-	-	-	-	180	200	225	250
	311 R2 (B)	18.3	77	16400	139	75	-	-	-	-	-	-	-	180	200	225	250
	311 R2 (C)	16.6	84	10300	96	90	-	-	-	-	-	-	-	180	200	225	250
	311 R2 (C)	21.3	66	13100	96	90	-	-	-	-	-	-	-	180	200	225	250
	311 R2 (C)	25.3	55	15500	95	90	-	-	-	-	-	-	-	180	200	225	250
	311 R3	53.0	26.4	16600	50	40	-	-	-	-	132	160	180	200	-	-	-
	311 R3	63.2	22.1	19700	50	40	-	-	-	-	132	160	180	200	-	-	-
	311 R3	68.0	20.6	21300	50	40	-	-	-	-	132	160	180	200	-	-	-
	311 R3	81.1	17.3	25300	50	40	-	-	-	-	132	160	180	200	-	-	-
	311 R3	96.3	14.5	27100	45	40	-	-	-	-	132	160	180	200	-	-	-
	311 R3	104	13.4	29300	45	40	-	-	-	-	132	160	180	200	-	-	-
	311 R3	124	11.3	30800	40	40	-	-	-	-	132	160	180	200	-	-	-
	311 R3	147	9.5	27000	30	40	-	-	-	-	132	160	180	200	-	-	-
	311 R4	154	9.1	22300	24	22	71	80	90	100	112	132	160	-	-	-	-
	311 R4	182	7.7	26300	24	22	71	80	90	100	112	132	160	-	-	-	-
	311 R4	198	7.1	28600	24	22	71	80	90	100	112	132	160	-	-	-	-
	311 R4	229	6.1	35100	25	22	71	80	90	100	112	132	160	-	-	-	-
311 R4	266	5.3	36700	23	22	71	80	90	100	112	132	160	-	-	-	-	
311 R4	294	4.8	37600	21	22	71	80	90	100	112	132	160	-	-	-	-	
311 R4	322	4.4	38700	19.9	22	71	80	90	100	112	132	160	-	-	-	-	

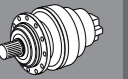
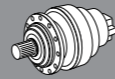

EQ313R										50000 Nm										
$n_1$ min <sup>-1</sup>		i	$n_2$ min <sup>-1</sup>	$m_{n2}$ Nm	$P_{n1}$ kW	$P_t$ kW	P(IEC)					$R_{n2}$ [N]								
							MC	MZ	HC/PC	HZ/PZ	FZ	MC	MZ	HC/PC	HZ/PZ	FZ				
1400	313 R2(B)	12.2	115	11700	150	75	-	-	-	-	-	180	200	225	250	-	-	46700	55200	16400
	313 R2(B)	15.9	88	15300	150	75	-	-	-	-	-	180	200	225	250	-	-	50500	59800	18000
	313 R2(B)	19.1	73	18400	150	75	-	-	-	-	-	180	200	225	250	-	-	53400	63200	19100
	313 R2(C)	16.8	83	10400	96	90	-	-	-	-	-	180	200	225	250	-	-	51400	60900	18300
	313 R2(C)	22.0	64	13400	95	90	-	-	-	-	-	180	200	225	250	-	-	55700	65900	20000
	313 R2(C)	26.4	53	16100	95	90	-	-	-	-	-	180	200	225	250	-	-	58900	69700	21300
	313 R3	53.7	26.1	16800	50	40	-	-	-	-	132	160	180	200	-	-	72800	86200	27000	
	313 R3	64.0	21.9	20000	50	40	-	-	-	-	132	160	180	200	-	-	76800	90900	28600	
	313 R3	69.9	20.0	21800	50	40	-	-	-	-	132	160	180	200	-	-	78900	93300	29500	
	313 R3	82.2	17.0	25700	50	40	-	-	-	-	132	160	180	200	-	-	82800	97900	31100	
	313 R3	97.5	14.4	30400	50	40	-	-	-	-	132	160	180	200	-	-	87100	103100	32900	
	313 R3	107	13.1	33400	50	40	-	-	-	-	132	160	180	200	-	-	89600	106000	34000	
	313 R3	127	11.0	39600	50	40	-	-	-	-	132	160	180	200	-	-	94300	111600	36000	
	313 R3	153	9.2	39000	41	40	-	-	-	-	132	160	180	200	-	-	99700	118000	38200	
	313 R4	185	7.0	26600	24	22	71	80	90	100	112	132	160	-	-	-	105500	124900	40700	
	313 R4	201	5.9	29000	24	22	71	80	90	100	112	132	160	-	-	-	108200	128000	41900	
	313 R4	237	5.0	34200	24	22	71	80	90	100	112	132	160	-	-	-	113700	134600	44200	
	313 R4	281	4.5	40600	24	22	71	80	90	100	112	132	160	-	-	-	119700	141700	46800	
	313 R4	309	4.1	44000	24	22	71	80	90	100	112	132	160	-	-	-	123100	145700	48300	
	313 R4	346	3.6	49200	24	22	71	80	90	100	112	132	160	-	-	-	127300	150700	50200	
	313 R4	387	3.6	46500	19.9	22	71	80	90	100	112	132	160	-	-	-	131800	156000	52100	
	313 R4	450	3.1	47200	17.3	22	71	80	90	100	112	132	160	-	-	-	137900	163200	54800	
	313 R4	496	2.8	52000	17.4	22	71	80	90	100	112	132	160	-	-	-	141900	168000	56600	
	313 R4	535	2.6	48000	14.9	22	71	80	90	100	112	132	160	-	-	-	145100	171800	58000	
	313 R4	647	2.2	49200	12.6	22	71	80	90	100	112	132	160	-	-	-	153700	181900	61800	
	313 R4	778	1.8	44700	9.5	22	71	80	90	100	112	132	160	-	-	-	162500	192300	65800	
900	313 R2(B)	12.2	74	14200	117	90	-	-	-	-	-	180	200	225	250	-	-	53300	63100	19100
	313 R2(B)	15.9	57	18200	115	90	-	-	-	-	-	180	200	225	250	-	-	57700	68300	20800
	313 R2(B)	19.1	47	22500	118	90	-	-	-	-	-	180	200	225	250	-	-	61000	72200	22100
	313 R2(C)	16.8	53	11800	70	108	-	-	-	-	-	180	200	225	250	-	-	58700	69500	21200
	313 R2(C)	22.0	41	15300	70	108	-	-	-	-	-	180	200	225	250	-	-	63600	75300	23200
	313 R2(C)	26.4	34	18400	70	108	-	-	-	-	-	180	200	225	250	-	-	67200	79600	24700
	313 R3	53.7	16.8	19100	37	48	-	-	-	-	132	160	180	200	-	-	83200	98400	31300	
	313 R3	64.0	14.1	22800	37	48	-	-	-	-	132	160	180	200	-	-	87700	103800	33100	
	313 R3	69.9	12.9	24900	37	48	-	-	-	-	132	160	180	200	-	-	90000	106500	34100	
	313 R3	82.2	11.0	29300	37	48	-	-	-	-	132	160	180	200	-	-	94500	111800	36000	
	313 R3	97.5	9.2	34700	37	48	-	-	-	-	132	160	180	200	-	-	99500	117700	38100	
	313 R3	107	8.4	38100	37	48	-	-	-	-	132	160	180	200	-	-	102300	121100	39300	
	313 R3	127	7.1	42800	35	48	-	-	-	-	132	160	180	200	-	-	107700	127500	41700	
	313 R3	153	5.9	39000	26	48	-	-	-	-	132	160	180	200	-	-	113900	134800	44300	
	313 R4	185	4.9	30400	17.5	26	71	80	90	100	112	132	160	-	-	-	120500	142600	47200	
	313 R4	201	4.5	33100	17.5	26	71	80	90	100	112	132	160	-	-	-	123500	146200	48500	
	313 R4	237	3.8	39100	17.6	26	71	80	90	100	112	132	160	-	-	-	129800	153600	51300	
	313 R4	281	3.2	46400	17.6	26	71	80	90	100	112	132	160	-	-	-	136700	161700	54300	
	313 R4	309	2.9	47100	16.2	26	71	80	90	100	112	132	160	-	-	-	140600	166300	56000	
	313 R4	346	2.6	54500	16.8	26	71	80	90	100	112	132	160	-	-	-	145400	172100	58100	
	313 R4	387	2.3	48700	13.4	26	71	80	90	100	112	132	160	-	-	-	150500	178100	60400	
	313 R4	450	2.0	49800	11.8	26	71	80	90	100	112	132	160	-	-	-	157400	186300	63500	
	313 R4	496	1.8	52300	11.2	26	71	80	90	100	112	132	160	-	-	-	162000	191800	65600	
	313 R4	535	1.7	51000	10.2	26	71	80	90	100	112	132	160	-	-	-	165700	196100	67200	
	313 R4	647	1.4	52400	8.6	26	71	80	90	100	112	132	160	-	-	-	175500	207600	71700	
	313 R4	778	1.2	47900	6.5	26	71	80	90	100	112	132	160	-	-	-	185500	219500	76200	

EQ314R										80000 Nm										
$n_1$ min <sup>-1</sup>		i	$n_2$ min <sup>-1</sup>	$m_{n2}$ Nm	$P_{n1}$ kW	$P_t$ kW	P(IEC)					$R_{n2}$ [N]								
							MC	MZ	HC/PC	HZ/PZ	FZ	MC	MZ	HC/PC	HZ/PZ	FZ				
1400	314 R3 (B)	51.1	27.4	38200	120	55	-	-	-	-	-	180	200	225	-	-	-	76600	89900	29800
	314 R3 (B)	65.5	21.4	50800	125	55	-	-	-	-	-	180	200	225	-	-	-	82600	96900	32400
	314 R3 (B)	77.8	18.0	52600	109	55	-	-	-	-	-	180	200	225	-	-	-	86900	102000	34300
	314 R3 (B)	82.3	17.0	53400	104	55	-	-	-	-	-	180	200	225	-	-	-	88400	103800	35000
	314 R3 (B)	97.6	14.3	56200	92	55	-	-	-	-	-	180	200	225	-	-	-	93000	109200	37000
	314 R3 (B)	113	12.3	49000	69	55	-	-	-	-	-	180	200	225	-	-	-	97300	114300	38900
	314 R3 (C)	70.7	19.8	36500	83	55	-	-	-	-	-	180	200	225	250	-	-	84500	99200	33300
	314 R3 (C)	90.7	15.4	39700	70	55	-	-	-	-	-	180	200	225	250	-	-	91000	106900	36200
	314 R3 (C)	108	13.0	41100	61	55	-	-	-	-	-	180	200	225	250	-	-	95800	112500	38300
	314 R3 (C)	114	12.3	49900	70	55	-	-	-	-	-	180	200	225	250	-	-	97400	114400	39000
	314 R3 (C)	135	10.4	52200	62	55	-	-	-	-	-	180	200	225	250	-	-	102600	120400	41300
	314 R3 (C)	157	8.9	52000	53	55	-	-	-	-	-	180	200	225	250	-	-	107300	126000	43400
	314 R4	160	8.7	33900	35	22	71	80	90	100	112	132	160	-	-	-	-	108000	126800	43700
	314 R4	189	7.4	40000	35	22	71	80	90	100	112	132	160	-	-	-	-	113500	133300	46200
	314 R4	238	5.9	50200	35	22	71	80	90	100	112	132	160	-	-	-	-	121500	142700	49800
	314 R4	276	5.1	58400	35	22	71	80	90	100	112	132	160	-	-	-	-	127100	149200	52400
	314 R4	354	3.9	74900	35	22	71	80	90	100	112	132	160	-	-	-	-	137000	160800	56900
	314 R4	421	3.3	79000	31	22	71	80	90	100	112	132	160	-	-	-	-	144200	169300	60300
	314 R4	445	3.1	67400	25	22	71	80	90	100	112	132	160	-	-	-	-	146700	172200	61400
	314 R4	528	2.7	69000	22	22	71	80	90	100	112	132	160	-	-	-	-	154400	181300	

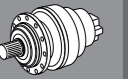
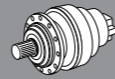

EQ315R										90000 Nm					
n <sub>1</sub> min <sup>-1</sup>	i	n <sub>2</sub> min <sup>-1</sup>	m <sub>n2</sub> Nm	P <sub>n1</sub> kW	Pt kW	P(IEC)	R <sub>n2</sub> [N]								
							MC	MZ	HC/PC	HZ/PZ	FZ				
1400	315 R4	225	6.2	66600	49	40	132	160	180	200	-	-	119600	140400	48900
	315 R4	269	5.2	79000	49	40	132	160	180	200	-	-	126100	148000	51900
	315 R4	345	4.1	96500	46	40	132	160	180	200	-	-	135900	159500	56400
	315 R4	409	3.4	98600	40	40	132	160	180	200	-	-	143000	167900	59700
	315 R4	525	2.7	99700	31	40	132	160	180	200	-	-	154100	181000	64900
	315 R4	623	2.2	100600	27	40	132	160	180	200	-	-	162300	190500	68700
	315 R4	659	2.1	89000	22	40	132	160	180	200	-	-	165000	193700	70000
	315 R4	782	1.8	91200	19.3	40	132	160	180	200	-	-	173700	203900	74100
	315 R4	909	1.5	75100	13.7	40	132	160	180	200	-	-	181700	213400	77900
900	315 R3 (B)	51.1	17.6	55000	111	90	-	-	180	200	225	250	87500	102700	34600
	315 R3 (B)	65.5	13.7	73100	115	90	-	-	180	200	225	250	94300	110700	37600
	315 R3 (B)	77.8	11.6	74800	99	90	-	-	180	200	225	250	99200	116500	39800
	315 R3 (B)	82.2	10.9	76000	95	90	-	-	180	200	225	250	100900	118500	40500
	315 R3 (B)	97.6	9.2	78100	83	90	-	-	180	200	225	250	106200	124700	42900
	315 R3 (B)	113	7.9	65000	59	90	-	-	180	200	225	250	111100	130500	45100
	315 R3 (C)	70.7	12.7	46200	67	108	-	-	180	200	225	250	96400	113200	38500
	315 R3 (C)	90.7	9.9	59700	68	108	-	-	180	200	225	250	103900	122000	41900
	315 R3 (C)	108	8.4	69500	67	108	-	-	180	200	225	250	109400	128500	44300
	315 R3 (C)	114	7.9	72900	66	108	-	-	180	200	225	250	111300	130600	45200
	315 R3 (C)	135	6.7	78600	60	108	-	-	180	200	225	250	117100	137500	47800
	315 R3 (C)	157	5.7	65000	43	108	-	-	180	200	225	250	122500	143900	50300
	315 R4	225	4.0	75800	36	48	132	160	180	200	-	-	136500	160300	56700
	315 R4	269	3.3	90500	36	48	132	160	180	200	-	-	143900	169000	60200
	315 R4	345	2.6	99700	31	48	132	160	180	200	-	-	155100	182100	65400
	315 R4	409	2.2	100700	26	48	132	160	180	200	-	-	163300	191700	69200
	315 R4	525	1.7	102000	21	48	132	160	180	200	-	-	176000	206600	75200
	315 R4	623	1.4	103000	17.6	48	132	160	180	200	-	-	185300	217500	79600
	315 R4	659	1.4	94700	15.3	48	132	160	180	200	-	-	188400	221200	81100
	315 R4	782	1.2	97100	13.2	48	132	160	180	200	-	-	198300	232900	85900
	315 R4	909	0.99	80000	9.4	48	132	160	180	200	-	-	206000	243000	90000

EQ316R										130000 Nm					
n <sub>1</sub> min <sup>-1</sup>	i	n <sub>2</sub> min <sup>-1</sup>	m <sub>n2</sub> Nm	P <sub>n1</sub> kW	Pt kW	P(IEC)	R <sub>n2</sub> [N]								
							MC	MZ	HC/PC	HZ/PZ	FZ				
1400	316 R3 (B)	51.1	27.4	47700	150	75	-	-	180	200	225	250	127400	141700	49700
	316 R3 (B)	65.5	21.4	61200	150	75	-	-	180	200	225	250	137300	152700	54100
	316 R3 (B)	77.8	18.0	66900	138	75	-	-	180	200	225	250	144500	160700	57200
	316 R3 (C)	70.7	19.8	42700	97	90	-	-	180	200	225	250	140400	156200	55400
	316 R3 (C)	90.7	15.4	54700	97	90	-	-	180	200	225	250	151300	168300	60300
	316 R3 (C)	108	13.0	65500	98	90	-	-	180	200	225	250	159300	177200	63800
	316 R4	225	6.2	96500	71	45	132	160	180	200	-	-	198800	221100	81600
	316 R4	269	5.2	101700	63	45	132	160	180	200	-	-	209600	233100	86500
	316 R4	289	4.8	107800	62	45	132	160	180	200	-	-	214200	238300	88700
	316 R4	345	4.1	109400	53	45	132	160	180	200	-	-	225900	251200	94000
	316 R4	409	3.4	112500	46	45	132	160	180	200	-	-	237800	264500	99600
	316 R4	443	3.2	119200	45	45	132	160	180	200	-	-	243500	270800	102200
	316 R4	525	2.7	119200	38	45	132	160	180	200	-	-	256300	285000	108200
	316 R4	623	2.2	116000	31	45	132	160	180	200	-	-	269800	300100	114500

EQ316R										130000 Nm					
n <sub>1</sub> min <sup>-1</sup>	i	n <sub>2</sub> min <sup>-1</sup>	m <sub>n2</sub> Nm	P <sub>n1</sub> kW	Pt kW	P(IEC)	R <sub>n2</sub> [N]								
							MC	MZ	HC/PC	HZ/PZ	FZ				
900	316 R3 (B)	51.1	17.6	58800	119	90	-	-	180	200	225	250	145400	161700	57600
	316 R3 (B)	65.5	13.7	74800	118	90	-	-	180	200	225	250	156700	174300	62600
	316 R3 (B)	77.8	11.6	76200	101	90	-	-	180	200	225	250	165000	183500	66300
	316 R3 (C)	70.7	12.7	48800	71	108	-	-	180	200	225	250	160300	178300	64200
	316 R3 (C)	90.7	9.9	62100	71	108	-	-	180	200	225	250	172800	192200	69800
	316 R3 (C)	108	8.4	74600	72	108	-	-	180	200	225	250	181900	202300	73900
	316 R4	225	4.0	109900	52	54	132	160	180	200	-	-	227000	252400	94500
	316 R4	269	3.3	115700	46	54	132	160	180	200	-	-	239300	266200	100300
	316 R4	289	3.1	119600	44	54	132	160	180	200	-	-	244600	272000	102700
	316 R4	345	2.6	124400	38	54	132	160	180	200	-	-	257900	286800	108900
	316 R4	409	2.2	122500	32	54	132	160	180	200	-	-	271500	302000	115300
	316 R4	443	2.0	128000	31	54	132	160	180	200	-	-	278000	309100	118400
	316 R4	525	1.7	125400	25	54	132	160	180	200	-	-	292600	325400	125300
	316 R4	623	1.4	120300	21	54	132	160	180	200	-	-	308000	342600	132700

EQ317R										150000 Nm					
n <sub>1</sub> min <sup>-1</sup>	i	n <sub>2</sub> min <sup>-1</sup>	m <sub>n2</sub> Nm	P <sub>n1</sub> kW	Pt kW	P(IEC)	R <sub>n2</sub> [N]								
							MC	MZ	HC/PC	HZ/PZ	FZ				
1400	317 R3 (B)	49.8	28.1	46500	150	90	-	-	180	200	225	250	162500	173000	49300
	317 R3 (B)	64.9	21.6	60600	150	90	-	-	180	200	225	250	176000	187400	53900
	317 R3 (B)	78.1	17.9	72900	150	90	-	-	180	200	225	250	186000	198100	57300
	317 R3 (B)	83.3	16.8	77800	150	90	-	-	180	200	225	250	189700	201900	58600
	317 R3 (B)	100	14.0	93600	150	90	-	-	180	200	225	250	200500	213500	62300
	317 R3 (B)	119	11.8	110000	149	90	-	-	180	200	225	250	211100	224700	65900
	317 R3 (C)	68.9	20.3	44400	104	100	-	-	180	200	225	250	179200	190800	55000
	317 R3 (C)	89.8	15.6	57900	104	100	-	-	180	200	225	250	194000	206600	60100
	317 R3 (C)	108	12.9	66300	98	100	-	-	180	200	225	250	205100	218400	63900
	317 R3 (C)	115	12.1	68100	95	100	-	-	180	200	225	250	209100	222600	65300
	317 R3 (C)	139	10.1	83300	96	100	-	-	180	200	225	250	221000	235400	69400
	317 R3 (C)	165	8.5	97800	95	100	-	-	180	200	225	250	232700	247800	73500
	317 R4	220	6.4	66100	50	50	132	160	180	200	-	-	253600	270100	80900
	317 R4	262	5.3	79400	50	50	132	160	180	200	-	-	267500	284800	85800
	317 R4	336	4.2	101600	50	50	132	160	180	200	-	-	288200	306900	93200
	317 R4	399	3.5	121100	50	50	132	160	180	200	-	-	303400	323100	98700
	317 R4	438	3.2	132800	50	50	132	160	180	200	-	-	312100	332300	101800
	317 R4	520	2.7	157500	50	50	132	160	180	200	-	-	328500	349800	107800
	317 R4	626	2.2	155000	41	50	132	160	180	200	-	-	347300	369800	114700
	317 R4	677	2.1	156400	38	50	132	160	180	200	-	-	355600	378600	117700
	317 R4	803	1.7	159500	33	50	132	160	180	200	-	-	374300	398500	124600
	317 R4	953	1.5	136700	24	50	132	160	180	200	-	-	394100	419600	132000
900	317 R3 (B)	49.8	18.1	53300	111	108	-	-	180	200	225	250	185600		

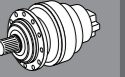
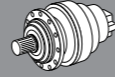

EQ317R										150000 Nm										
n <sub>1</sub> min <sup>-1</sup>		i	n <sub>2</sub> min <sup>-1</sup>	m <sub>n2</sub> Nm	P <sub>n1</sub> kW	Pt kW	P(IEC)					R <sub>n2</sub> [N]								
							MC	MZ	HC/PC	HZ/PZ	FZ	MC	MZ	HC/PC	HZ/PZ	FZ				
900	317 R4	220	4.1	75500	37	09	132	160	180	200	-	-	289600	308300	93700	-	-	-	-	-
	317 R4	262	3.4	90800	37	09	132	160	180	200	-	-	305400	325100	99400	-	-	-	-	-
	317 R4	336	2.7	116500	37	09	132	160	180	200	-	-	329100	350400	108000	-	-	-	-	-
	317 R4	399	2.3	137800	37	09	132	160	180	200	-	-	346400	368900	114400	-	-	-	-	-
	317 R4	438	2.1	150100	36	09	132	160	180	200	-	-	356300	379400	118000	-	-	-	-	-
	317 R4	520	1.7	168000	34	09	132	160	180	200	-	-	375100	399400	124900	-	-	-	-	-
	317 R4	626	1.4	155000	26	09	132	160	180	200	-	-	396600	422200	132900	-	-	-	-	-
	317 R4	677	1.3	164500	26	09	132	160	180	200	-	-	406000	432200	136400	-	-	-	-	-
	317 R4	803	1.1	167800	22	09	132	160	180	200	-	-	427400	455000	144400	-	-	-	-	-
	317 R4	953	0.94	145000	16.2	09	132	160	180	200	-	-	442000	470000	150000	-	-	-	-	-

EQ319R										300000 Nm											
n <sub>1</sub> min <sup>-1</sup>		i	n <sub>2</sub> min <sup>-1</sup>	m <sub>n2</sub> Nm	P <sub>n1</sub> kW	Pt kW	P(IEC)					R <sub>n2</sub> [N]									
							MC	MZ	HC/PC	HZ/PZ	FZ	MC	MZ	HC/PC	HZ/PZ	FZ					
1400	319 R4 (B)	249	5.6	224100	149	95	180	200	225	250	-	-	379800	418500	112500	-	-	-	-	-	
	319 R4 (B)	320	4.4	289400	150	95	180	200	225	250	-	-	409400	451000	122200	-	-	-	-	-	
	319 R4 (B)	379	3.7	310400	136	95	180	200	225	250	-	-	430900	474800	129400	-	-	-	-	-	
	319 R4 (B)	401	3.5	316600	131	95	180	200	225	250	-	-	438200	482800	131800	-	-	-	-	-	
	319 R4 (B)	475	3.0	284000	99	95	180	200	225	250	-	-	460900	507800	139400	-	-	-	-	-	
	319 R4 (B)	563	2.5	292300	86	95	180	200	225	250	-	-	485200	534600	147600	-	-	-	-	-	
	319 R4 (B)	655	2.1	299700	76	95	180	200	225	250	-	-	507700	559300	155200	-	-	-	-	-	
	319 R4 (C)	345	4.1	193900	93	115	180	200	225	250	-	-	418800	461400	125400	-	-	-	-	-	
	319 R4 (C)	442	3.2	245600	92	115	180	200	225	250	-	-	451300	497200	136200	-	-	-	-	-	
	319 R4 (C)	525	2.7	294900	93	115	180	200	225	250	-	-	475100	523500	144200	-	-	-	-	-	
	319 R4 (C)	555	2.5	312200	93	115	180	200	225	250	-	-	483100	532300	146900	-	-	-	-	-	
	319 R4 (C)	657	2.1	299800	76	115	180	200	225	250	-	-	508200	559900	155400	-	-	-	-	-	
	319 R4 (C)	780	1.8	308500	66	115	180	200	225	250	-	-	535000	589400	164500	-	-	-	-	-	
	319 R4 (C)	906	1.5	316300	58	115	180	200	225	250	-	-	559700	616600	173000	-	-	-	-	-	
	900	319 R4 (B)	249	3.6	257400	110	114	180	200	225	250	-	-	433700	477800	130300	-	-	-	-	-
		319 R4 (B)	320	2.8	333600	111	114	180	200	225	250	-	-	467400	514900	141600	-	-	-	-	-
319 R4 (B)		379	2.4	348100	98	114	180	200	225	250	-	-	492000	542100	149900	-	-	-	-	-	
319 R4 (B)		401	2.2	348200	92	114	180	200	225	250	-	-	500300	551200	152800	-	-	-	-	-	
319 R4 (B)		475	1.9	305700	69	114	180	200	225	250	-	-	526300	579800	161600	-	-	-	-	-	
319 R4 (B)		563	1.6	314500	60	114	180	200	225	250	-	-	554000	610400	171100	-	-	-	-	-	
319 R4 (B)		655	1.4	322500	52	114	180	200	225	250	-	-	579600	638600	179900	-	-	-	-	-	
319 R4 (C)		345	2.6	220700	68	138	180	200	225	250	-	-	478100	526800	145200	-	-	-	-	-	
319 R4 (C)		442	2.0	280500	67	138	180	200	225	250	-	-	515300	567700	157800	-	-	-	-	-	
319 R4 (C)		525	1.7	320100	65	138	180	200	225	250	-	-	542500	597700	167100	-	-	-	-	-	
319 R4 (C)		555	1.6	330000	63	138	180	200	225	250	-	-	551600	607700	170200	-	-	-	-	-	
319 R4 (C)		657	1.4	322700	52	138	180	200	225	250	-	-	580200	639200	180100	-	-	-	-	-	
319 R4 (C)		780	1.2	332000	45	138	180	200	225	250	-	-	610800	672900	190700	-	-	-	-	-	
319 R4 (C)		906	0.99	340000	40	138	180	200	225	250	-	-	638000	702000	200000	-	-	-	-	-	

EQ318R										250000 Nm											
n <sub>1</sub> min <sup>-1</sup>		i	n <sub>2</sub> min <sup>-1</sup>	m <sub>n2</sub> Nm	P <sub>n1</sub> kW	Pt kW	P(IEC)					R <sub>n2</sub> [N]									
							MC	MZ	HC/PC	HZ/PZ	FZ	MC	MZ	HC/PC	HZ/PZ	FZ					
1400	318 R4 (B)	225	6.2	199400	147	90	180	200	225	250	-	-	365900	373400	125900	-	-	-	-	-	
	318 R4 (B)	288	4.9	214500	123	90	180	200	225	250	-	-	394300	402400	136900	-	-	-	-	-	
	318 R4 (B)	342	4.1	223100	108	90	180	200	225	250	-	-	415100	423600	144900	-	-	-	-	-	
	318 R4 (B)	362	3.9	226000	103	90	180	200	225	250	-	-	422100	430800	147600	-	-	-	-	-	
	318 R4 (B)	430	3.3	235100	91	90	180	200	225	250	-	-	444400	453500	156300	-	-	-	-	-	
	318 R4 (B)	499	2.8	209000	69	90	180	200	225	250	-	-	464900	474500	164300	-	-	-	-	-	
	318 R4 (C)	311	4.5	173600	92	110	180	200	225	250	-	-	403400	411700	140400	-	-	-	-	-	
	318 R4 (C)	399	3.5	223700	93	110	180	200	225	250	-	-	434700	443700	152500	-	-	-	-	-	
	318 R4 (C)	474	3.0	240500	84	110	180	200	225	250	-	-	457700	467100	161500	-	-	-	-	-	
	318 R4 (C)	501	2.8	243700	81	110	180	200	225	250	-	-	465400	474900	164500	-	-	-	-	-	
	318 R4 (C)	595	2.4	250000	70	110	180	200	225	250	-	-	489900	500000	174200	-	-	-	-	-	
	318 R4 (C)	691	2.0	216600	52	110	180	200	225	250	-	-	503000	523100	183200	-	-	-	-	-	
	900	318 R4 (B)	225	4.0	224200	106	108	180	200	225	250	-	-	365900	373400	125900	-	-	-	-	-
		318 R4 (B)	288	3.1	237500	88	108	180	200	225	250	-	-	394300	402400	136900	-	-	-	-	-
		318 R4 (B)	342	2.6	247100	77	108	180	200	225	250	-	-	415100	423600	144900	-	-	-	-	-
318 R4 (B)		362	2.5	250000	74	108	180	200	225	250	-	-	422100	430800	147600	-	-	-	-	-	
318 R4 (B)		430	2.1	250000	62	108	180	200	225	250	-	-	444400	453500	156300	-	-	-	-	-	
318 R4 (B)		499	1.8	220900	47	108	180	200	225	250	-	-	464900	474500	164300	-	-	-	-	-	
318 R4 (C)		311	2.9	199000	68	132	180	200	225	250	-	-	403400	411700	140400	-	-	-	-	-	
318 R4 (C)		399	2.3	246300	66	132	180	200	225	250	-	-	434700	443700	152500	-	-	-	-	-	
318 R4 (C)		474	1.9	250000	56	132	180	200	225	250	-	-	457700	467100	161500	-	-	-	-	-	
318 R4 (C)		501	1.8	250000	53	132	180	200	225	250	-	-	465400	474900	164500	-	-	-	-	-	
318 R4 (C)		595	1.5	250000	45	132	180	200	225	250	-	-	489900	500000	174200	-	-	-	-	-	
318 R4 (C)		691	1.3	233400	36	132	180	200	225	250	-	-	503000	523100	183200	-	-	-	-	-	

EQ321R										350000 Nm										
n <sub>1</sub> min <sup>-1</sup>		i	n <sub>2</sub> min <sup>-1</sup>	m <sub>n2</sub> Nm	P <sub>n1</sub> kW	Pt kW	P(IEC)					R <sub>n2</sub> [N]								
							MC	MZ	HC/PC	HZ/PZ	FZ	MC	MZ	HC/PC	HZ/PZ	FZ				
1400	321 R4 (B)	221	6.3	200400	150	105	180	200	225	250	-	-	449800	533400	648800	-	-	-	-	-
	321 R4 (B)	288	4.9	261300	150	105	180	200	225	250	-	-	487000	577500	708700	-	-	-	-	-
	321 R4 (B)	347	4.0	314500	150	105	180	200	225	250	-	-	514800	610500	753900	-	-	-	-	-
	321 R4 (B)	370	3.8	335300	150	105	180	200	225	250	-	-	524800	622400	770200	-	-	-	-	-
	321 R4 (B)	446	3.1	403600	150	105	180	200	225	250	-	-	554800	658000	819300	-	-	-	-	-
	321																			

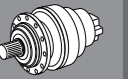
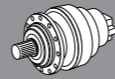

EQ300L

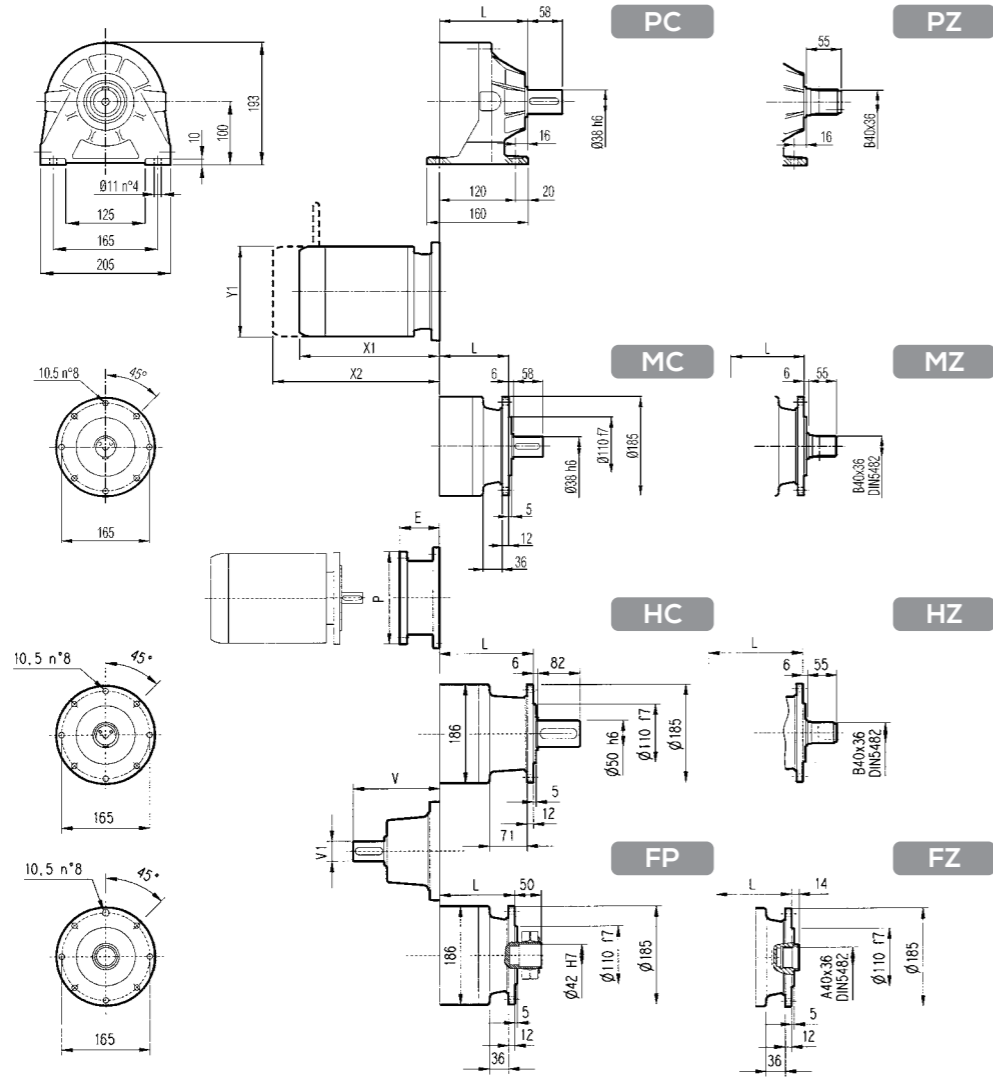

EQ300R

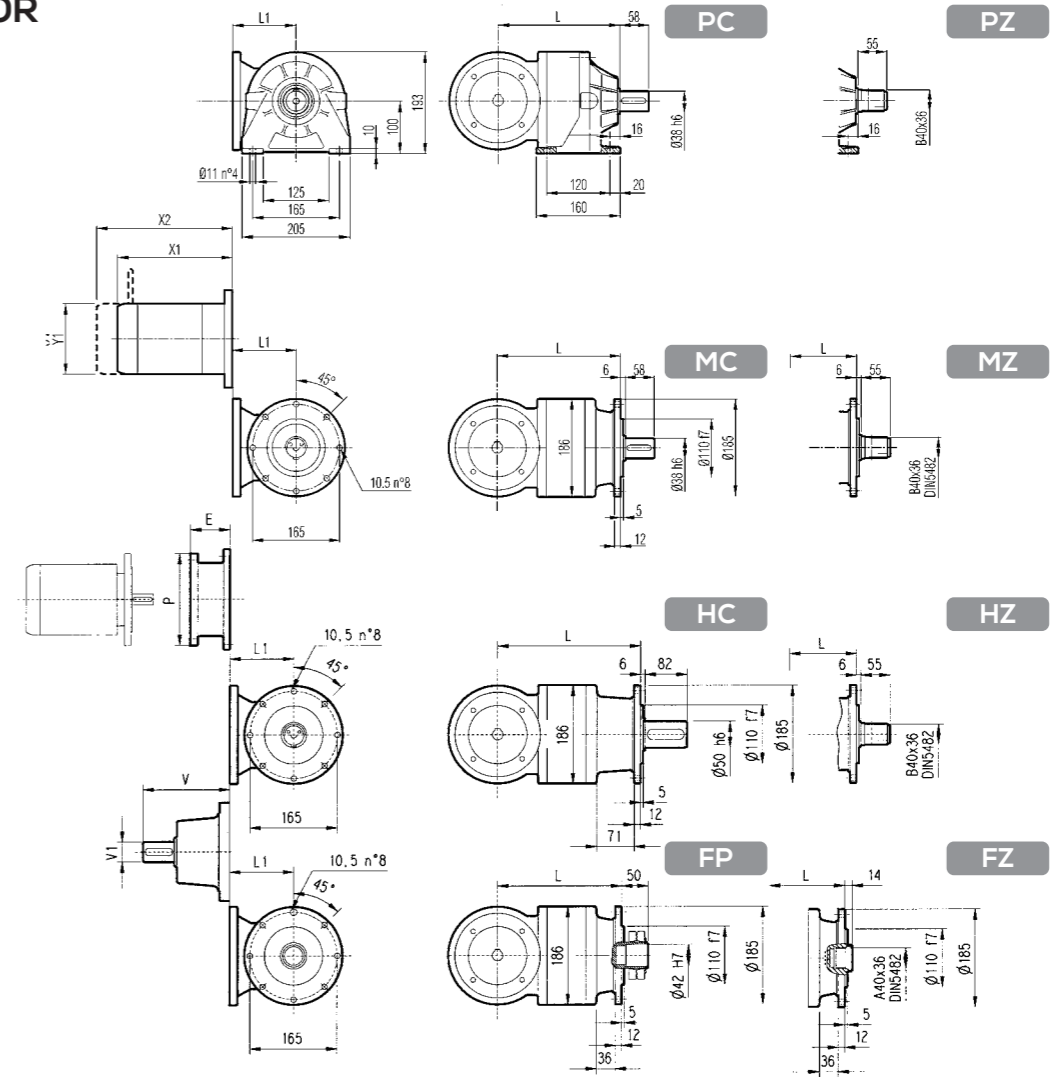

FP  $M_{2max} = 1200 \text{ Nm}$

	L				Kg				输入轴 Input Shaft					
	MC-MZ	PC-PZ	HC-HZ	FP-FZ	MC-MZ	PC-PZ	HC-HZ	FP-FZ	V	V1	Kg	V	V1	Kg
EQ300L1	80	86	115	80	18	23	20	16	137.5	24	6	158	38	7
EQ300L2	133	139	168	133	22	27	24	20	137.5	24	6	158	38	7
EQ300L3	186	192	221	186	26	31	28	24	137.5	24	6	158	38	7
EQ300L4	239	245	274	239	30	35	32	28	137.5	24	6	158	38	7

	P71		P80		P90		P100		P112		P132	
	E	P	E	P	E	P	E	P	E	P	E	P
EQ300L1	65	160	84	200	84	200	94	250	94	250	114	300
EQ300L2	65	160	84	200	84	200	94	250	94	250	114	300
EQ300L3	65	160	84	200	84	200	94	250	94	250	114	300
EQ300L4	65	160	84	200	84	200	94	250	94	250	114	300

	S1+M1S			S1+M1L			S2+M2S			S3+M3S			S3+M3L			S4+M4		
	X1	X2	Y1	X1	X2	Y1	X1	X2	Y1	X1	X2	Y1	X1	X2	Y1	X1	X2	Y1
EQ300L1	229	292	138	253	314	138	280	352	156	325	421	195	357	449	195	460	571	258
EQ300L2	229	292	138	253	314	138	280	352	156	325	421	195	357	449	195	460	571	258
EQ300L3	229	292	138	253	314	138	280	352	156	325	421	195	357	449	195	460	571	258
EQ300L4	229	292	138	253	314	138	280	352	156	325	421	195	357	449	195	460	571	258

FP  $M_{2max} = 1200 \text{ Nm}$

	L				L1	Kg				输入轴 Input Shaft					
	MC-MZ	PC-PZ	HC-HZ	FP-FZ		MC-MZ	PC-PZ	HC-HZ	FP-FZ	V	V1	Kg	V	V1	Kg
EQ300R2	172	178	207	172	122	32	37	34	30	137.5	24	6	158	38	7
EQ300R3	225	231	260	225	122	36	41	38	34	137.5	24	6	158	38	7
EQ300R4	278	284	313	278	122	40	45	42	38	137.5	24	6	158	38	7

	P71		P80		P90		P100		P112		P132	
	E	P	E	P	E	P	E	P	E	P	E	P
EQ300R2	65	160	84	200	84	200	94	250	94	250	114	300
EQ300R3	65	160	84	200	84	200	94	250	94	250	114	300
EQ300R4	65	160	84	200	84	200	94	250	94	250	114	300

	S1+M1S			S1+M1L			S2+M2S			S3+M3S			S3+M3L			S4+M4		
	X1	X2	Y1	X1	X2	Y1	X1	X2	Y1	X1	X2	Y1	X1	X2	Y1	X1	X2	Y1
EQ300R2	229	292	138	253	314	138	328	400	156	373	469	195	405	497	195	508	619	258
EQ300R3	229	292	138	253	314	138	328	400	156	373	469	195	405	497	195	-	-	-
EQ300R4	229	292	138	253	314	138	328	400	156	373	469	195	-	-	-	-	-	-

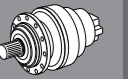
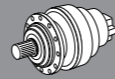

EQ300L / ER300R

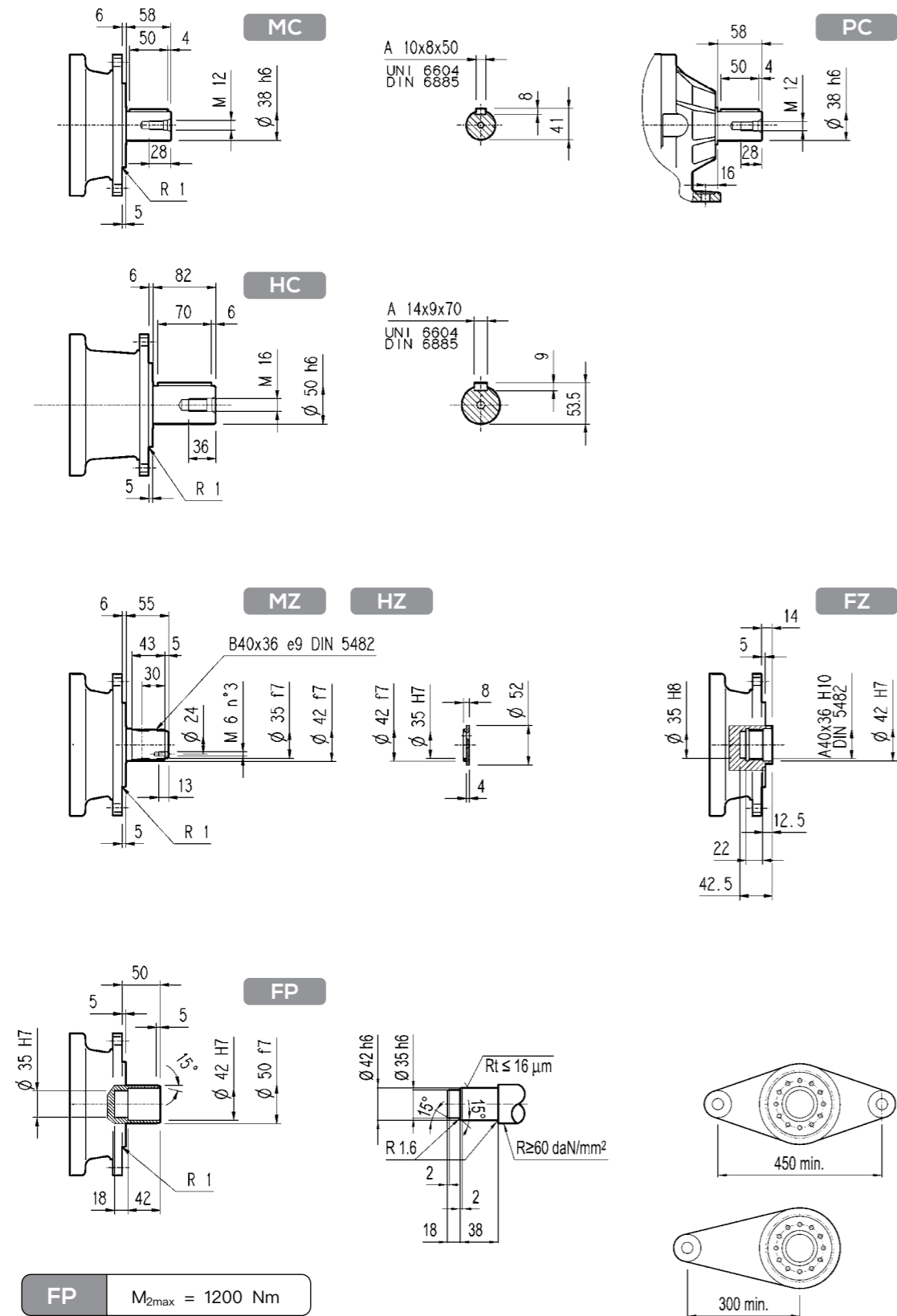

法兰 Flange

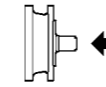

材料: 45#钢  
Material: 45 # steel

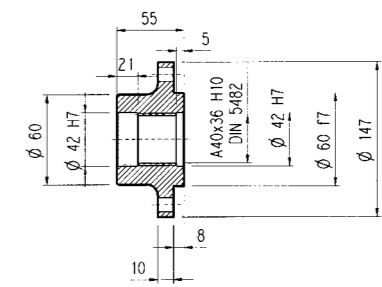
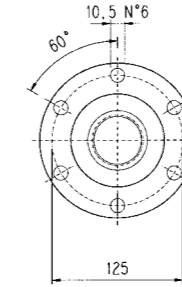

WOA

小齿轮 Pinion

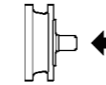

	m	z	x	dp	di	de	H	A	B	C	☆
PBE	4.5	14	0.507	63	56	75.5	55	0	0	0	□
PCE	5	14	0.500	70	62.5	84.8	65	0	10	53	□
PDC	6	12	0.250	72	61	84.8	59	14	4	54	□
PDE	6	14	0.500	84	73	99.6	65	0	10	54	□

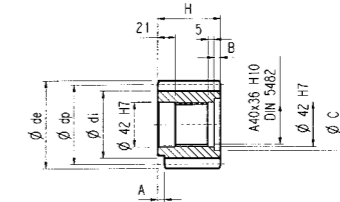

☆ 材料 Material  
□ 42CrMo钢调质 42CrMo steel quenched and tempered  
■ 20CrMnTi钢表面渗碳 Surface carburizing of 20CrMnTi steel

套筒联轴节 Sleeve Coupling

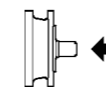

材料: 42CrMo钢  
Material: 42CrMo steel

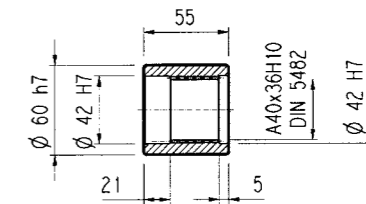

MOA

花键棒 Spline Bar

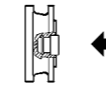

材料: 42CrMo钢表面硬度HRC45-55  
Material: 42CrMo steel surface hardness HRC45-55

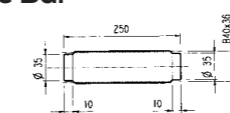

BOA

收缩盘 Shrink Disk

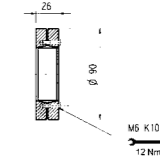
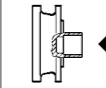

GOA

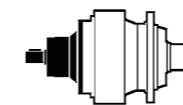

	Input	V	V1	V2	V4	V5	A	B	F	L	S	D	U
EQ300L1	V01A	137.5	24	36	120	186	8	7	27	30	3	M8	19
	V01B	158	38	58	120	186	10	8	41	50	4	M12	28
EQ300L2	V01A	137.5	24	36	120	186	8	7	27	30	3	M8	19
	V01B	158	38	58	120	186	10	8	41	50	4	M12	28
EQ300L3	V01A	137.5	24	36	120	186	8	7	27	30	3	M8	19
	V01B	158	38	58	120	186	10	8	41	50	4	M12	28
EQ300L4	V01A	137.5	24	36	120	186	8	7	27	30	3	M8	19
	V01B	158	38	58	120	186	10	8	41	50	4	M12	28
EQ300R2/3/4	V01A	137.5	24	36	120	186	8	7	27	30	3	M8	19
	V01B	158	38	58	120	186	10	8	41	50	4	M12	28

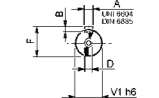
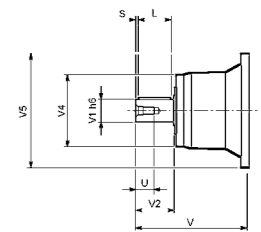

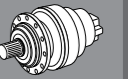
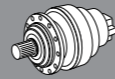

输出轴上的径向载荷位置系数  
RADIAL LOAD POSITION COEFFICIENT ON OUTPUT SHAFT

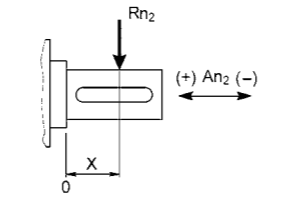
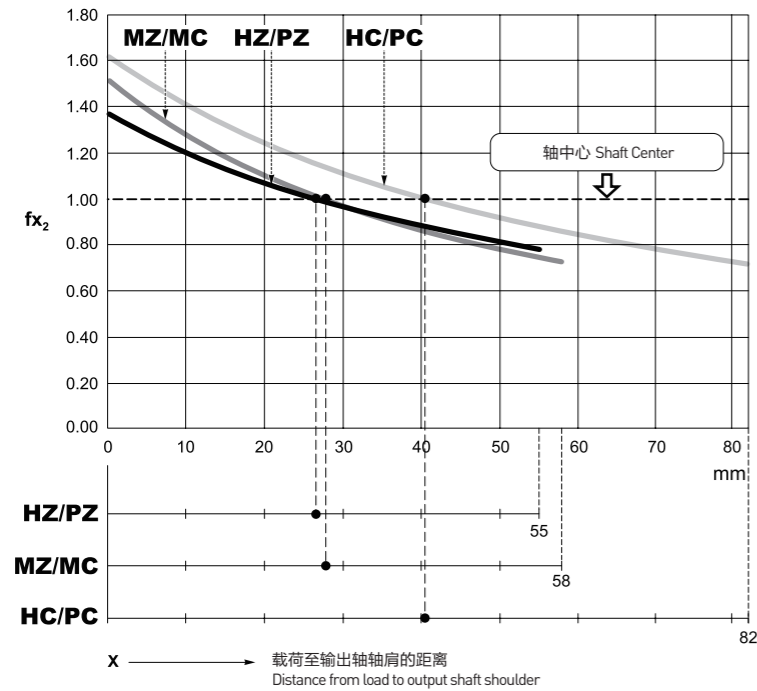

$$R_{x2} = R_{n2} \cdot f_{x2}$$

$$A_{n2}(\pm) = R_{n2} \cdot f_{a2}(\pm)$$

	$f_{a2}(+)$	$f_{a2}(-)$
HZ	1.18	1.18
HC	1.29	1.29
MC	2.20	2.20
MZ	2.04	2.04

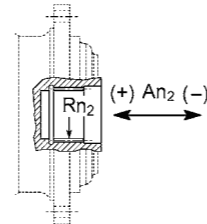

$$A_{n2}(\pm) = R_{n2} \cdot f_{a2}(\pm)$$

	$f_{a2}(+)$	$f_{a2}(-)$
FZ	1.00	1.00

输入转速 $n_1=1000\text{min}^{-1}$ 且假设使用寿命=10000小时, 输入轴上的允许悬臂荷载。  
当输入转速和/或使用寿命不同于这里所列举的值时, 参见样本: 校核。  
Input speed  $n_1=1000\text{min}^{-1}$  and assuming a service life of 10000 hours, the allowable cantilever load on the input shaft.  
When the input speed and/or service life are different from the values listed here, refer to sample: verification.

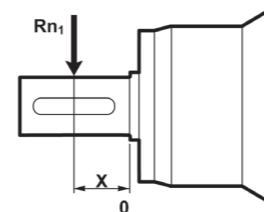
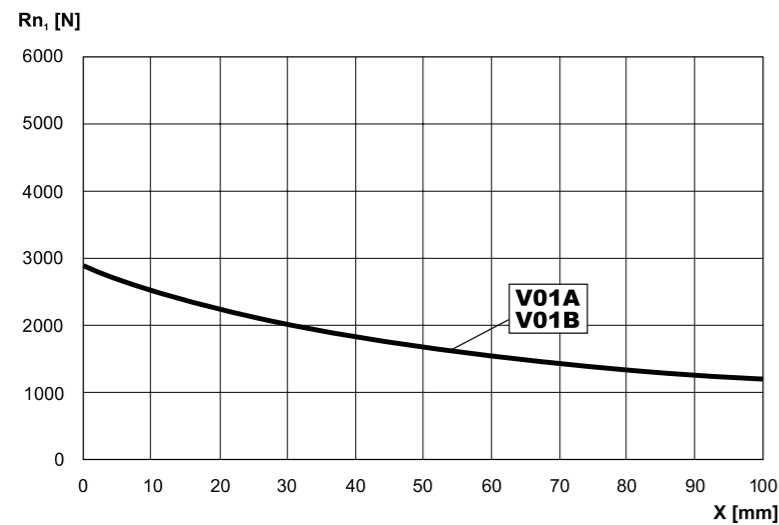

EQ301L

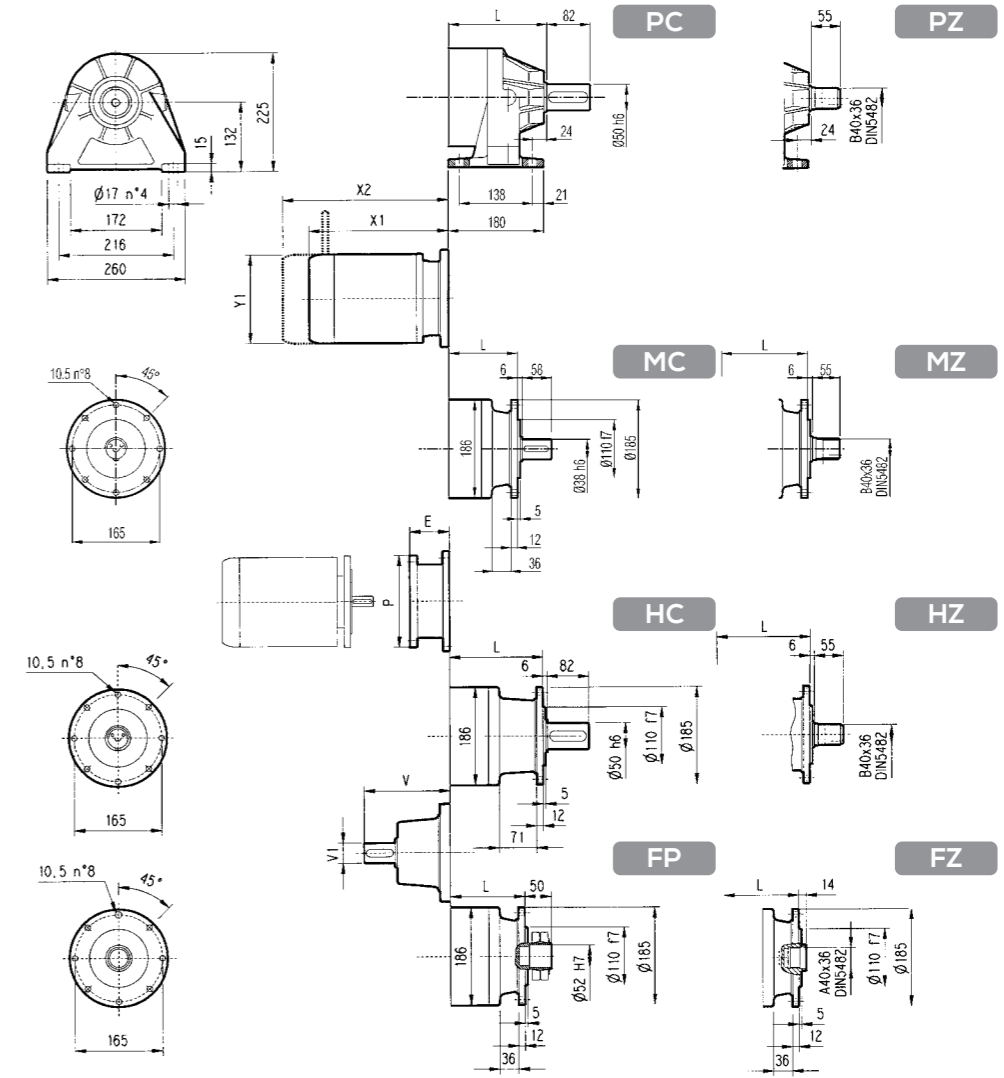

FP  $M_{2max} = 2400 \text{ Nm}$

	L				$\text{Kg}$				输入轴 Input Shaft					
	MC-MZ	PC-PZ	HC-HZ	FP-FZ	MC-MZ	PC-PZ	HC-HZ	FP-FZ	V	V1	$\text{Kg}$	V	V1	$\text{Kg}$
EQ301L1	92	132	126	92	21	26	23	19	137.5	24	6	158	38	7
EQ301L2	145	185	176	145	25	30	27	23	137.5	24	6	158	38	7
EQ301L3	198	238	232	198	29	34	31	27	137.5	24	6	158	38	7
EQ301L4	251	291	285	251	33	38	35	31	137.5	24	6	158	38	7

	P71		P80		P90		P100		P112		P132	
	E	P	E	P	E	P	E	P	E	P	E	P
EQ301L1	65	160	84	200	84	200	94	250	94	250	114	300
EQ301L2	65	160	84	200	84	200	94	250	94	250	114	300
EQ301L3	65	160	84	200	84	200	94	250	94	250	114	300
EQ301L4	65	160	84	200	84	200	94	250	94	250	114	300

	S1+M1S			S1+M1L			S2+M2S			S3+M3S			S3+M3L			S4+M4		
	X1	X2	Y1	X1	X2	Y1	X1	X2	Y1	X1	X2	Y1	X1	X2	Y1	X1	X2	Y1
EQ301L1	229	292	138	253	314	138	280	352	156	325	421	195	357	449	195	460	571	258
EQ301L2	229	292	138	253	314	138	280	352	156	325	421	195	357	449	195	460	571	258
EQ301L3	229	292	138	253	314	138	280	352	156	325	421	195	357	449	195	460	571	258
EQ301L4	229	292	138	253	314	138	280	352	156	325	421	195	357	449	195	460	571	258

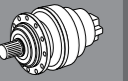
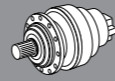

EQ301R

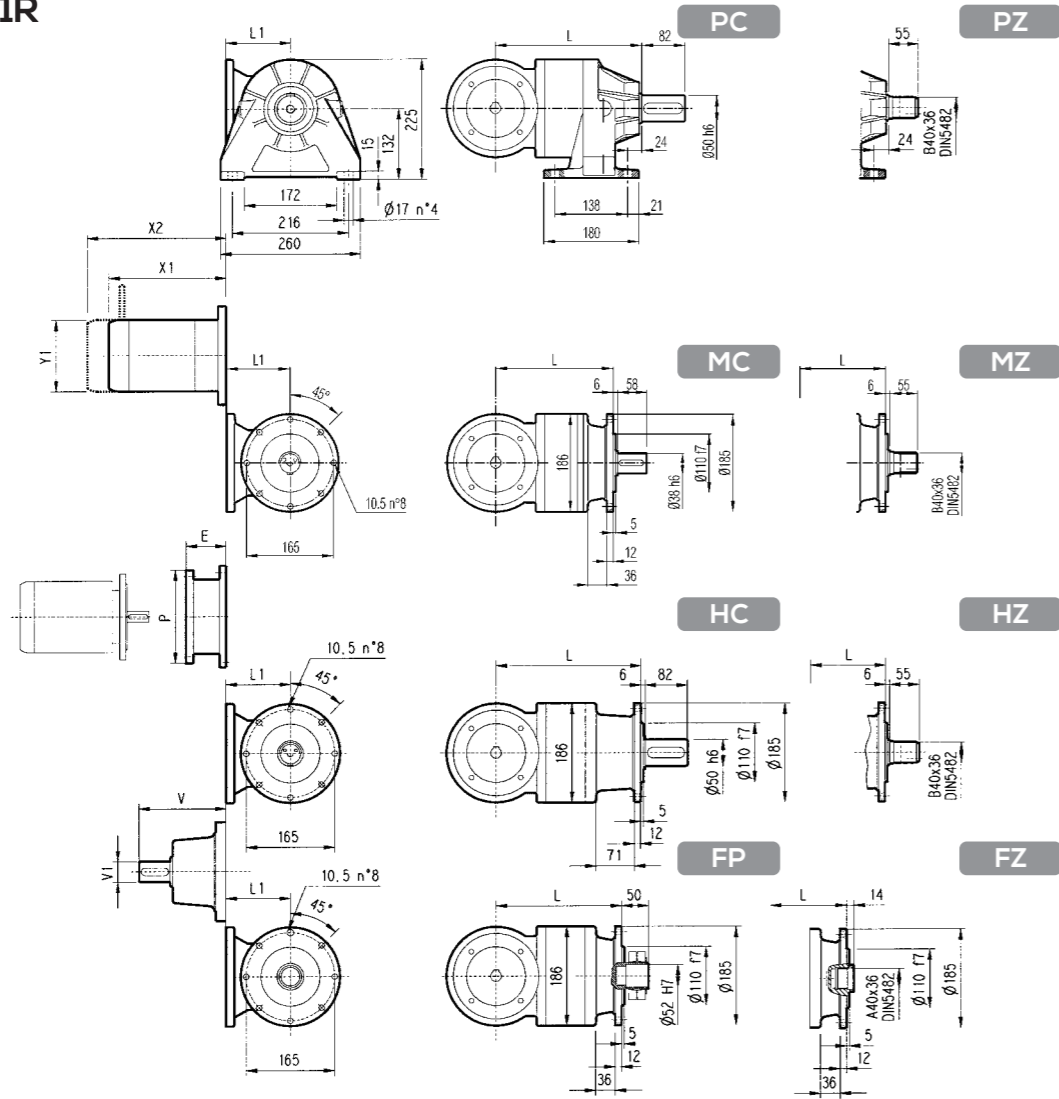

EQ301L / ER301R

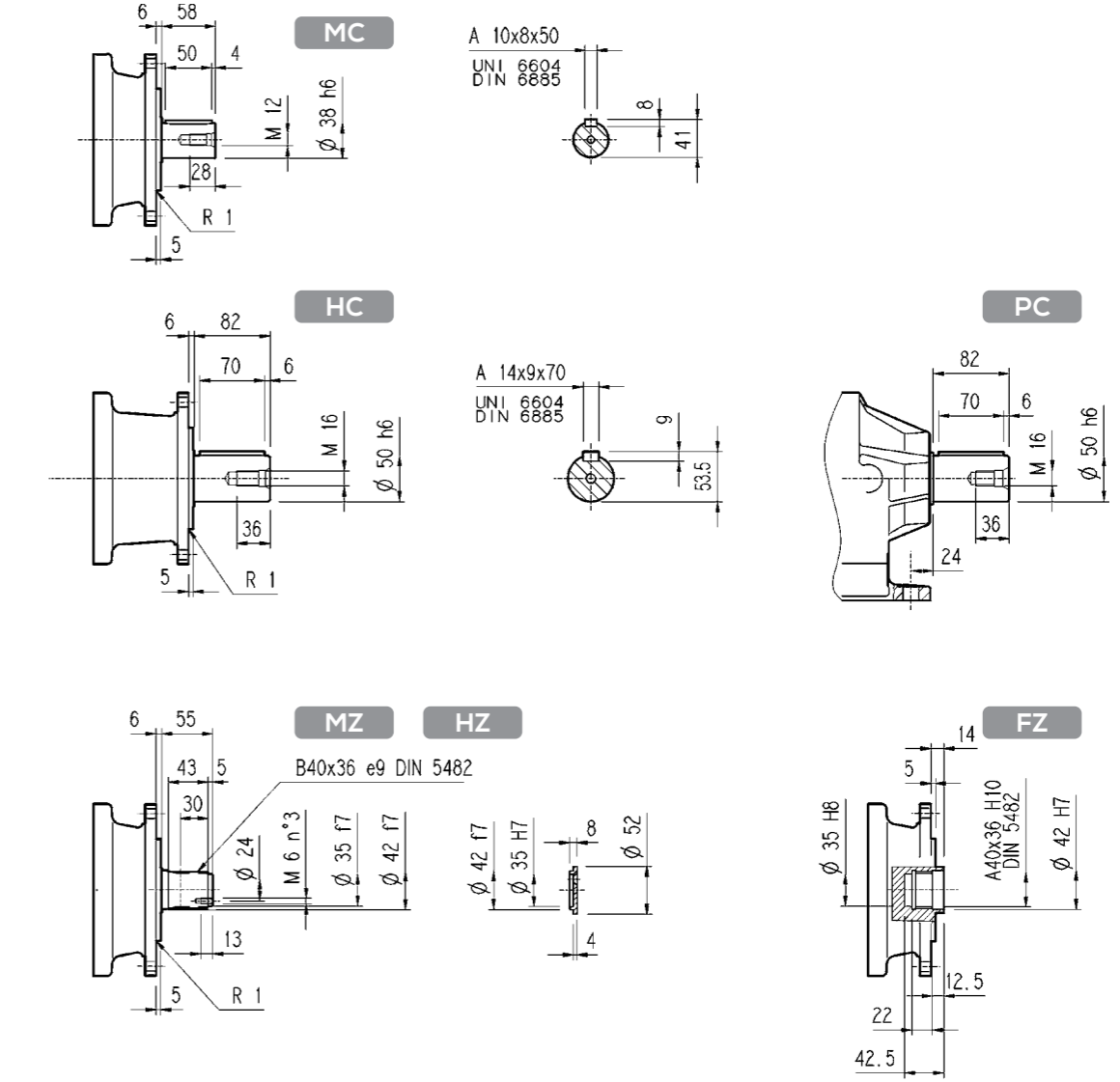

FP  $M_{2max} = 2400 \text{ Nm}$

	L				L1	$K_g$				输入轴 Input Shaft					
	MC-MZ	PC-PZ	HC-HZ	FP-FZ		MC-MZ	PC-PZ	HC-HZ	FP-FZ	V	V1	$K_g$	V	V1	$K_g$
EQ301R2	184	225	219	184	122	35	42	37	33	137.5	24	6	158	38	7
EQ301R3	237	278	272	237	122	39	46	41	37	137.5	24	6	158	38	7
EQ301R4	290	331	325	290	122	43	50	45	41	137.5	24	6	158	38	7

	P71		P80		P90		P100		P112		P132	
	E	P	E	P	E	P	E	P	E	P	E	P
EQ301R2	65	160	84	200	84	200	94	250	94	250	114	300
EQ301R3	65	160	84	200	84	200	94	250	94	250	114	300
EQ301R4	65	160	84	200	84	200	94	250	94	250	114	300

	S1+M1S			S1+M1L			S2+M2S			S3+M3S			S3+M3L			S4+M4		
	X1	X2	Y1	X1	X2	Y1	X1	X2	Y1	X1	X2	Y1	X1	X2	Y1	X1	X2	Y1
EQ301R2	229	292	138	253	314	138	328	400	156	373	469	195	405	497	195	508	619	258
EQ301R3	229	292	138	253	314	138	328	400	156	373	469	195	405	497	195	-	-	-
EQ301R4	229	292	138	253	314	138	328	400	156	373	469	195	-	-	-	-	-	-

FP  $M_{2max} = 2400 \text{ Nm}$

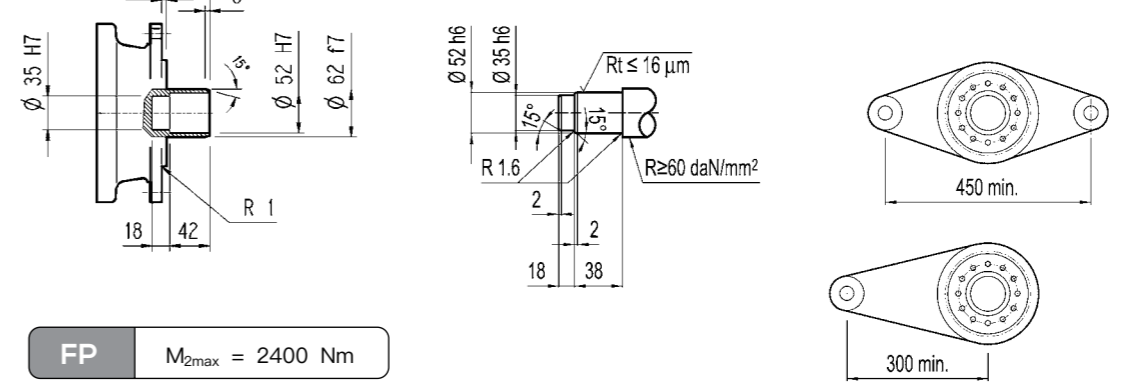



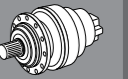
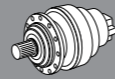

EQ303L

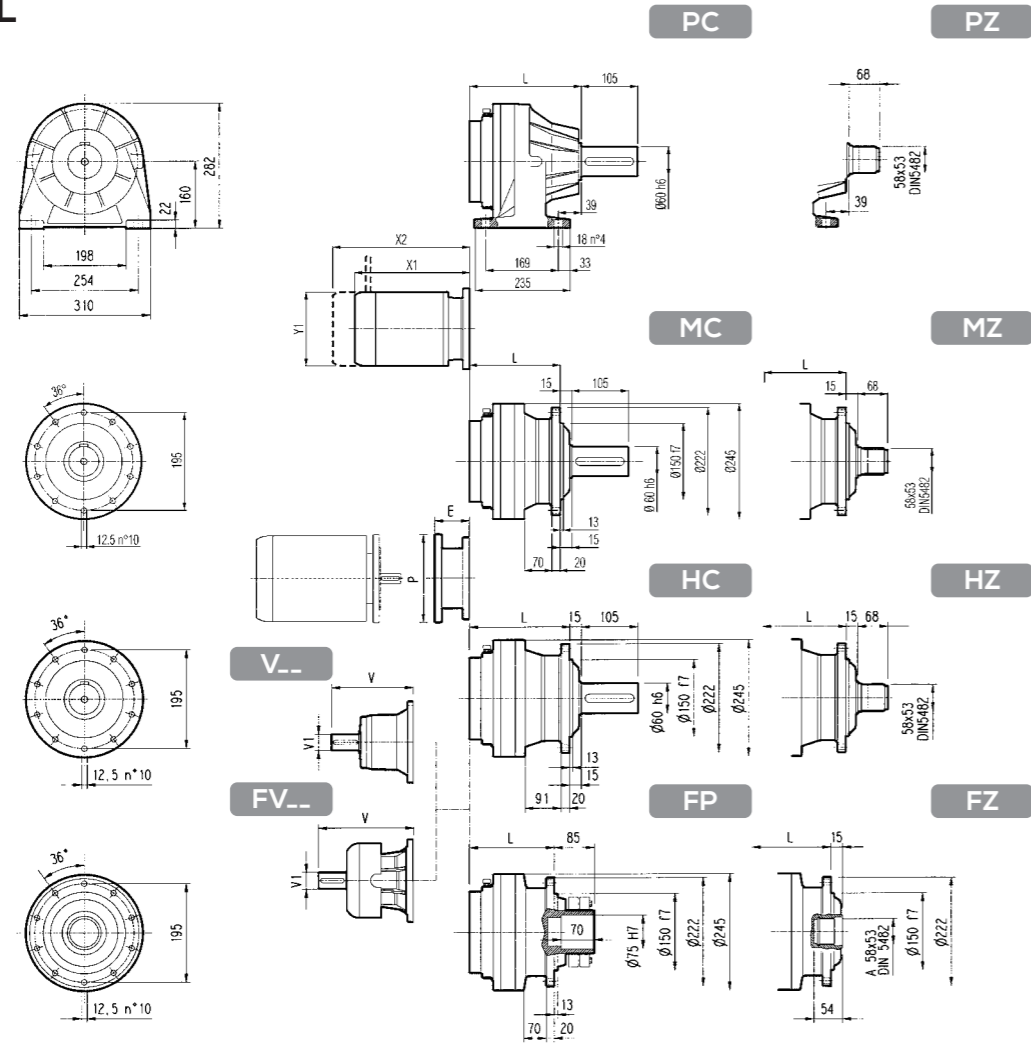

EQ303R

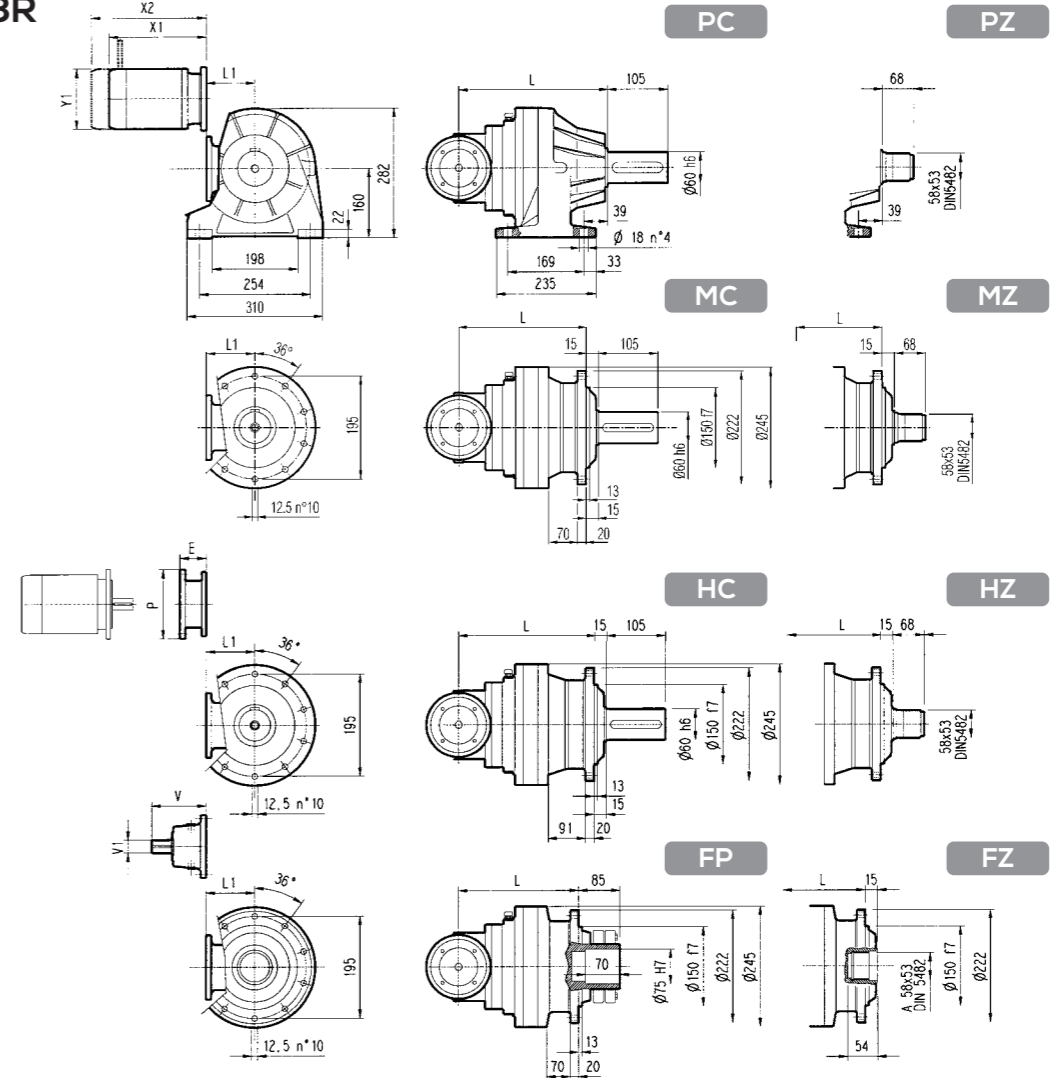

FP  $M_{2max} = 3500 \text{ Nm}$

	L				Kg				输入轴 Input Shaft				输入轴 Input Shaft				
	MC-MZ	PC-PZ	HC-HZ	FP-FZ	MC-MZ	PC-PZ	HC-HZ	FP-FZ	V	V1	Kg	V	V1	Kg	V	V1	Kg
EQ303L1	125	165	150	125	31	40	35	31	239	48	15	-	-	-	276	48	17
EQ303L2	178	218	203	178	34	44	39	35	137.5	24	6	158	38	7	-	-	-
EQ303L3	231	271	256	231	39	48	43	39	137.5	24	6	158	38	7	-	-	-
EQ303L4	284	324	309	284	43	52	47	43	137.5	24	6	158	38	7	-	-	-

	P71		P80		P90		P100		P112		P132		P160		P180		P200	
	E	P	E	P	E	P	E	P	E	P	E	P	E	P	E	P	E	P
EQ303L1	-	-	-	-	-	-	-	-	-	-	114	300	144	350	144	350	174	400
EQ303L2	65	160	84	200	84	200	94	250	94	250	114	300	144	350	-	-	-	-
EQ303L3	65	160	84	200	84	200	94	250	94	250	114	300	144	350	-	-	-	-
EQ303L4	65	160	84	200	84	200	94	250	94	250	114	300	144	350	-	-	-	-

	S1+M1S			S1+M1L			S2+M2S			S3+M3S			S3+M3L			S4+M4			S5+M5S			S5+M5L		
	X1	X2	Y1	X1	X2	Y1	X1	X2	Y1	X1	X2	Y1	X1	X2	Y1	X1	X2	Y1	X1	X2	Y1	X1	X2	Y1
EQ303L1	-	-	-	-	-	-	-	-	-	-	-	-	-	-	-	460	571	258	552	692	310	596	736	310
EQ303L2	229	292	138	253	314	138	280	352	156	325	421	195	357	449	195	460	571	258	-	-	-	-	-	-
EQ303L3	229	292	138	253	314	138	280	352	156	325	421	195	357	449	195	460	571	258	-	-	-	-	-	-
EQ303L4	229	292	138	253	314	138	280	352	156	325	421	195	357	449	195	460	571	258	-	-	-	-	-	-

FP  $M_{2max} = 3500 \text{ Nm}$

	L				L1	Kg				输入轴 Input Shaft					
	MC-MZ	PC-PZ	HC-HZ	FP-FZ		MC-MZ	PC-PZ	HC-HZ	FP-FZ	V	V1	Kg	V	V1	Kg
EQ303R2	217	257	242	217	140	51	60	55	51	137.5	24	6	158	38	7
EQ303R3	270	310	295	270	122	49	58	53	49	137.5	24	6	158	38	7
EQ303R4	323	363	348	323	122	53	62	57	53	137.5	24	6	158	38	7

	P71		P80		P90		P100		P112		P132	
	E	P	E	P	E	P	E	P	E	P	E	P
EQ303R2	65	160	84	200	84	200	94	250	94	250	114	300
EQ303R3	65	160	84	200	84	200	94	250	94	250	114	300
EQ303R4	65	160	84	200	84	200	94	250	94	250	114	300

	S1+M1S			S1+M1L			S2+M2S			S3+M3S			S3+M3L			S4+M4		
	X1	X2	Y1	X1	X2	Y1	X1	X2	Y1	X1	X2	Y1	X1	X2	Y1	X1	X2	Y1
EQ303R2	-	-	-	-	-	-	-	-	-	328	400	156	373	469	195	405	497	195
EQ303R3	229	292	138	253	314	138	280	352	156	325	421	195	357	449	195	405	497	195
EQ303R4	229	292	138	253	314	138	280	352	156	325	421	195	357	449	195	405	497	195



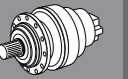
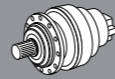

输出轴上的径向载荷位置系数  
RADIAL LOAD POSITION COEFFICIENT ON OUTPUT SHAFT

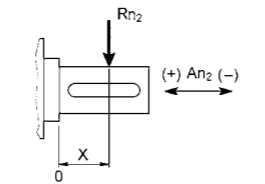
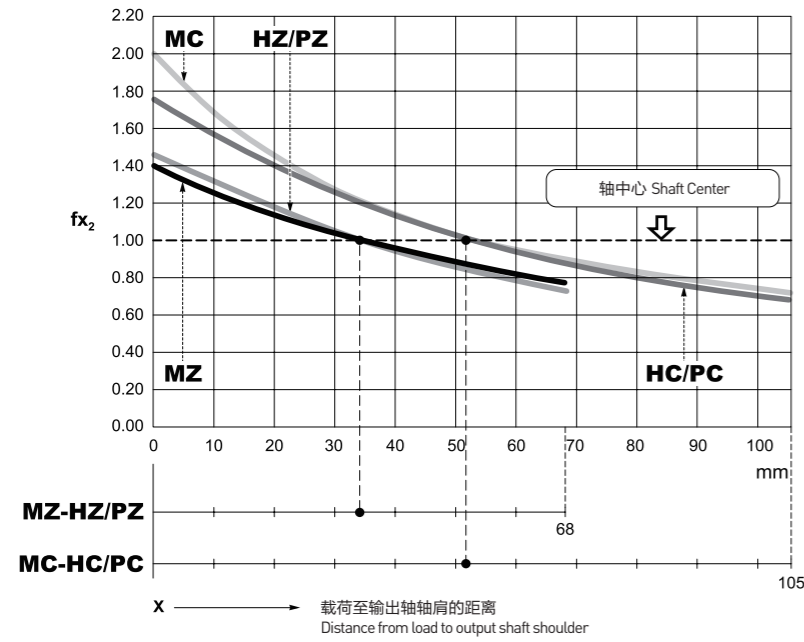

$R_{v2} = R_{n2} \cdot f_{x2}$

$An_2 (\pm) = R_{n2} \cdot fa_2 (\pm)$

	$fa_2 (+)$	$fa_2 (-)$
HZ/PZ	0.74	0.59
HC/PC	0.86	0.69
MC	2.04	2.04
MZ	1.74	1.74

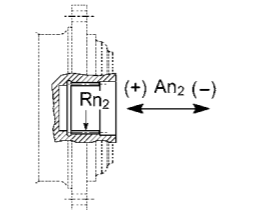

$An_2 (\pm) = R_{n2} \cdot fa_2 (\pm)$

	$fa_2 (+)$	$fa_2 (-)$
FZ	1.00	1.00

输入转速 $n_1=1000\text{min}^{-1}$ 且假设使用寿命=10000小时, 输入轴上的允许悬臂荷载。  
当输入转速和/或使用寿命不同于这里所列举的值时, 参见样本: 校核。  
Input speed  $n_1=1000\text{min}^{-1}$  and assuming a service life of 10000 hours, the allowable cantilever load on the input shaft.  
When the input speed and/or service life are different from the values listed here, refer to sample: verification.

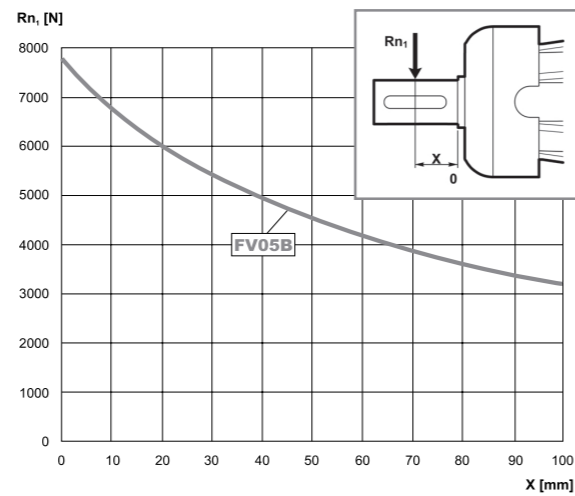
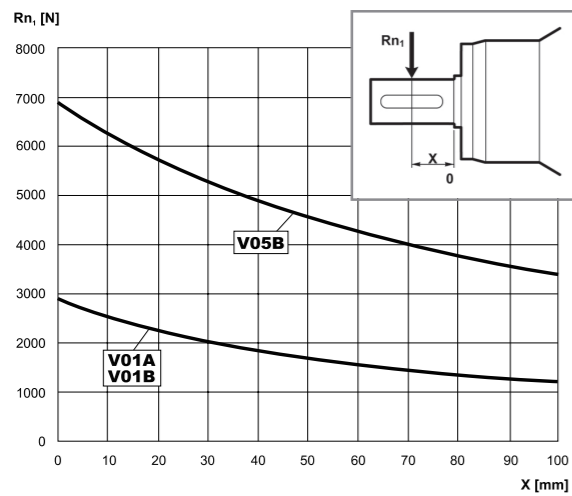

EQ304L

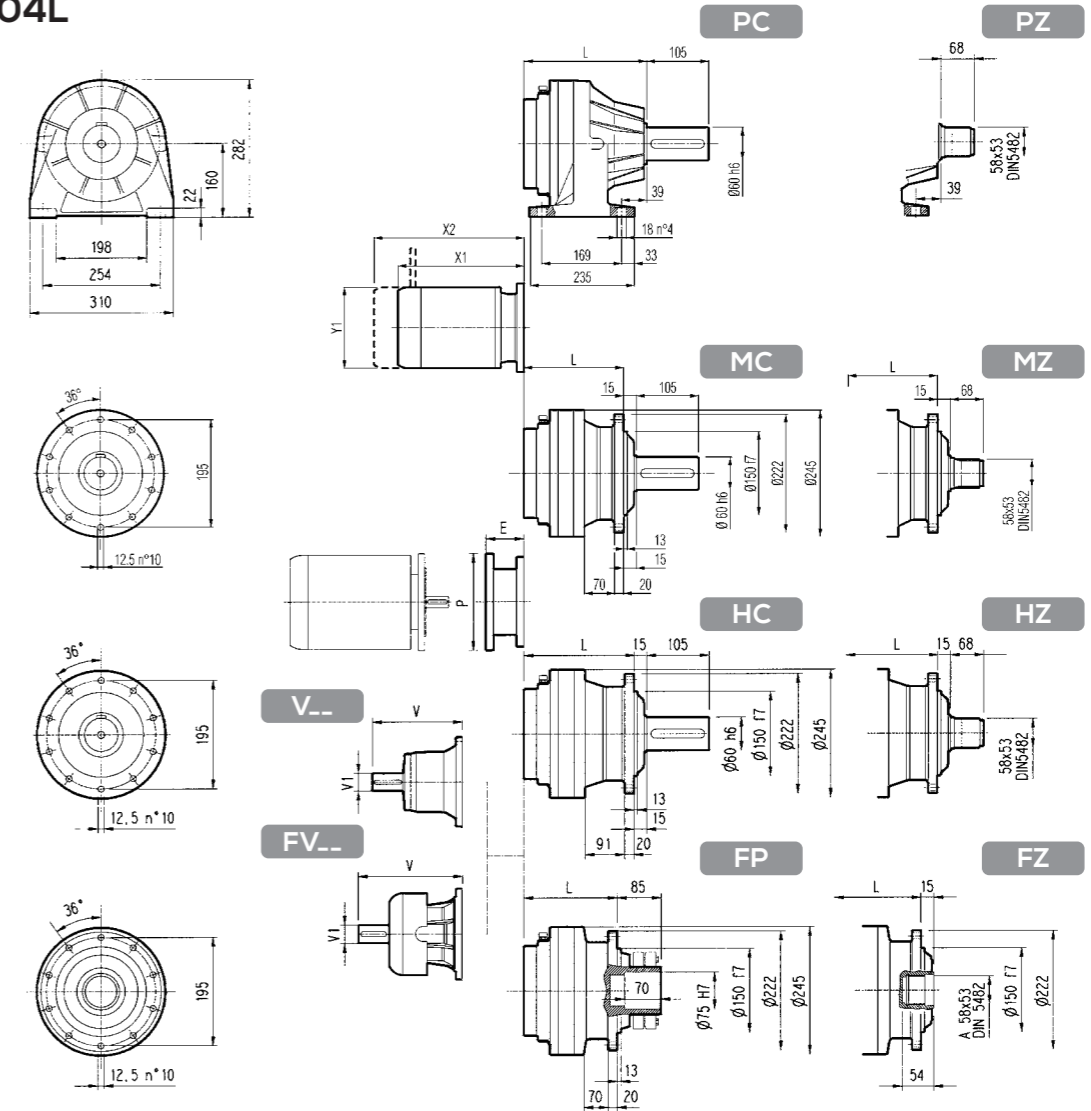

FP  $M_{2max} = 6000 \text{ Nm}$

	L				Kg				输入轴 Input Shaft					输入轴 Input Shaft						
	MC-MZ	PC-PZ	HC-HZ	FP-FZ	MC-MZ	PC-PZ	HC-HZ	FP-FZ	V	V1	Kg	V	V1	Kg	V	V1	Kg	V	V1	Kg
EQ304L1	125	165	150	125	31	40	35	31	239	48	15	-	-	-	276	48	17	-	-	-
EQ304L2	190	230	215	190	38	47	42	38	137.5	24	6	158	38	7	-	-	-	-	-	-
EQ304L3	243	283	268	243	42	51	46	42	137.5	24	6	158	38	7	-	-	-	-	-	-
EQ304L4	296	336	321	296	46	55	50	46	137.5	24	6	158	38	7	-	-	-	-	-	-

	P71		P80		P90		P100		P112		P132		P160		P180		P200	
	E	P	E	P	E	P	E	P	E	P	E	P	E	P	E	P	E	P
EQ304L1	-	-	-	-	-	-	-	-	-	-	114	300	144	350	144	350	174	400
EQ304L2	65	160	84	200	84	200	94	250	94	250	114	300	144	350	-	-	-	-
EQ304L3	65	160	84	200	84	200	94	250	94	250	114	300	144	350	-	-	-	-
EQ304L4	65	160	84	200	84	200	94	250	94	250	114	300	144	350	-	-	-	-

	S1+M1S			S1+M1L			S2+M2S			S3+M3S			S3+M3L			S4+M4			S5+M5S			S5+M5L		
	X1	X2	Y1	X1	X2	Y1	X1	X2	Y1	X1	X2	Y1	X1	X2	Y1	X1	X2	Y1	X1	X2	Y1	X1	X2	Y1
EQ304L1	-	-	-	-	-	-	-	-	-	-	-	-	-	-	-	460	571	258	552	692	310	596	736	310
EQ304L2	229	292	138	253	314	138	280	352	156	325	421	195	357	449	195	460	571	258	-	-	-	-	-	-
EQ304L3	229	292	138	253	314	138	280	352	156	325	421	195	357	449	195	460	571	258	-	-	-	-	-	-
EQ304L4	229	292	138	253	314	138	280	352	156	325	421	195	357	449	195	460	571	258	-	-	-	-	-	-

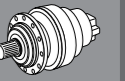
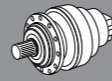

EQ304R

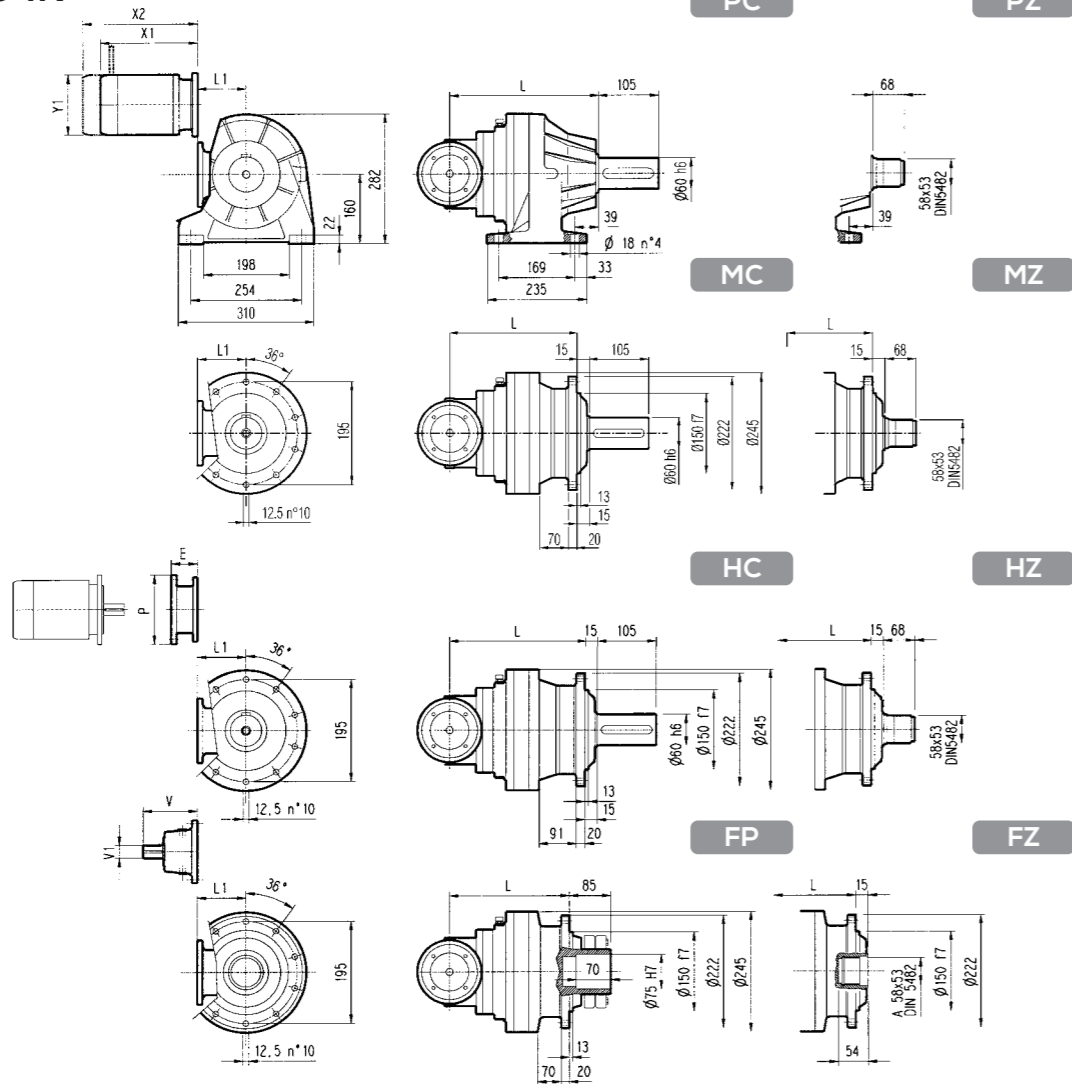

EQ304L / ER304R

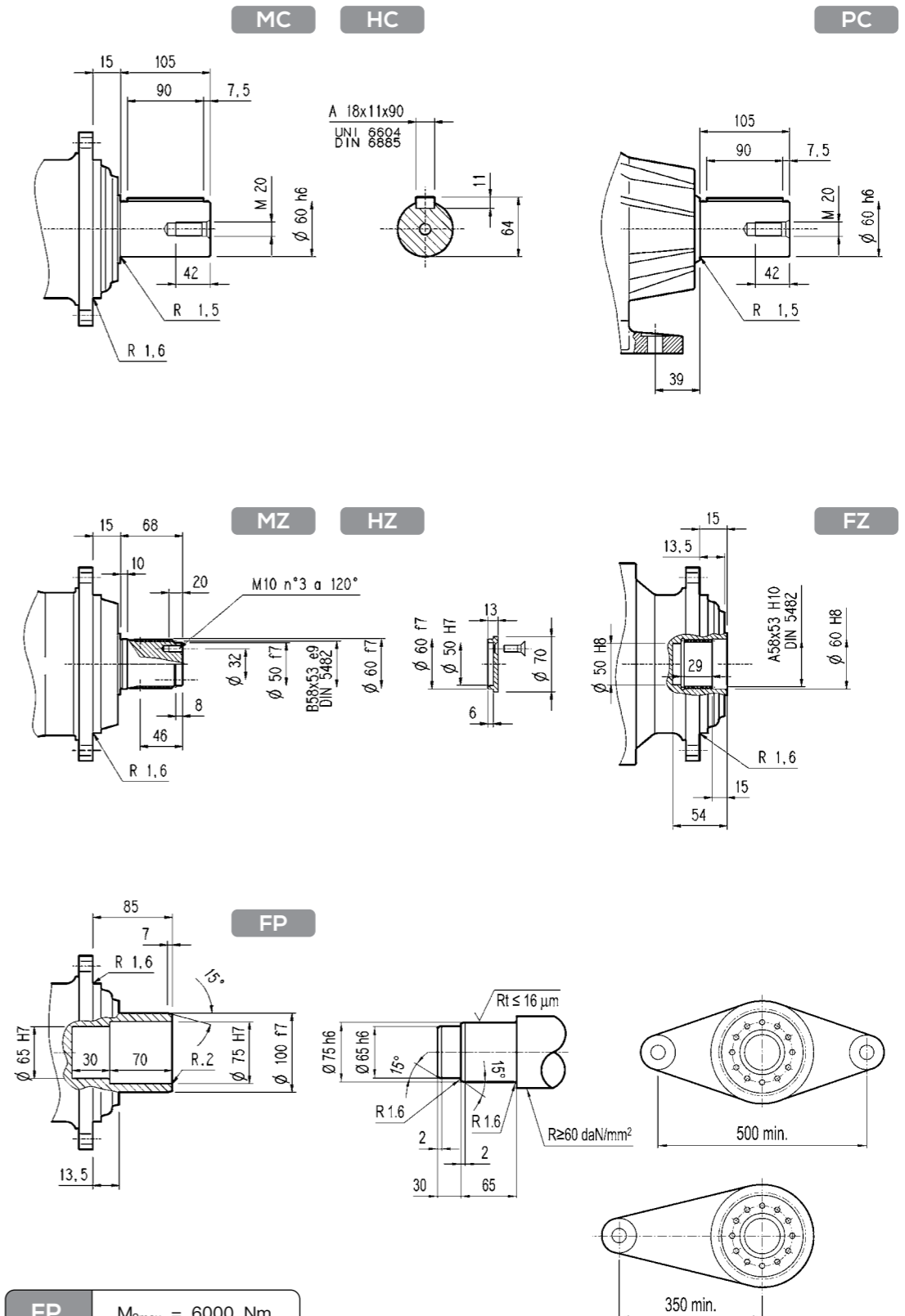

FP M<sub>2max</sub> = 6000 Nm

	L				L1	Kg				输入轴 Input Shaft					
	MC-MZ	PC-PZ	HC-HZ	FP-FZ		MC-MZ	PC-PZ	HC-HZ	FP-FZ	V	V1	Kg	V	V1	Kg
EQ304R2	217	257	242	217	140	51	60	55	51	137.5	24	6	158	38	7
EQ304R3	282	322	307	282	122	52	61	56	52	137.5	24	6	158	38	7
EQ304R4	335	375	360	335	122	56	65	60	56	137.5	24	6	158	38	7

	P71		P80		P90		P100		P112		P132	
	E	P	E	P	E	P	E	P	E	P	E	P
EQ304R2	65	160	84	200	84	200	94	250	94	250	114	300
EQ304R3	65	160	84	200	84	200	94	250	94	250	114	300
EQ304R4	65	160	84	200	84	200	94	250	94	250	114	300

	S1+M1S			S1+M1L			S2+M2S			S3+M3S			S3+M3L			S4+M4		
	X1	X2	Y1	X1	X2	Y1	X1	X2	Y1	X1	X2	Y1	X1	X2	Y1	X1	X2	Y1
EQ304R2	-	-	-	-	-	-	328	400	156	373	469	195	405	497	195	508	619	258
EQ304R3	229	292	138	253	314	138	328	400	156	373	469	195	405	497	195	-	-	-
EQ304R4	229	292	138	253	314	138	328	400	156	373	469	195	405	497	195	-	-	-

FP M<sub>2max</sub> = 6000 Nm

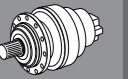
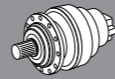

法兰 Flange

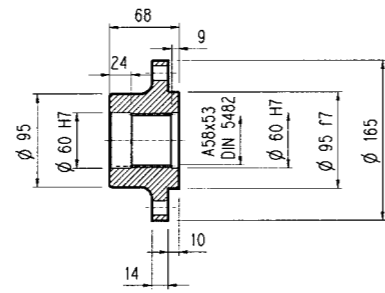
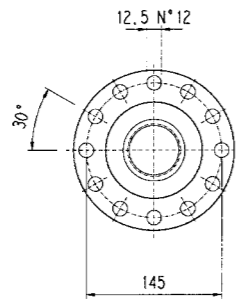
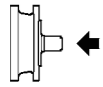

WOA

材料: 45#钢  
Material: 45 # steel

小齿轮 Pinion



	m	z	x	dp	di	de	H	A	B	C	☆
PCL1	5	19	0	95	82	104	77	12	9	72	□
PCL2	5	19	0	95	82	104	68	0	0	0	□
PCM	5	20	0	100	87.5	110	68	18	0	0	■
PCP	5	22	0	110	97.5	120	68	18	0	0	■
PDE	6	14	0.500	84	75	99.6	68	0	0	0	□
PDI	6	18	0.500	108	99	123.6	68	0	0	0	□
PDM	6	20	0.833	120	115	140	68	0	0	0	□
PFD	8	13	0.675	104	95	127.6	68	0	0	0	■
PFE1	8	14	0	112	92	126	68	0	0	0	■
PFE2	8	14	0	112	92	126	80	0	12	72	■
PFF	8	15	0	120	100	136	68	0	0	0	□
PFP	8	22	0	176	156	190	77	12	10	71	□
PHG	10	16	0.500	160	145	188	75	0	7	72	□

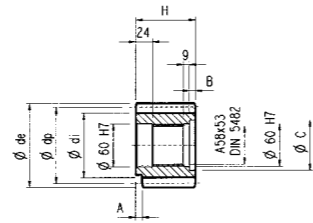

P...

☆ 材料 Material  
□ 42CrMo钢调质 42CrMo steel quenched and tempered  
■ 20CrMnTi钢表面渗碳 Surface carburizing of 20CrMnTi steel

套筒联轴节 Sleeve Coupling



材料: 42CrMo钢  
Material: 42CrMo steel

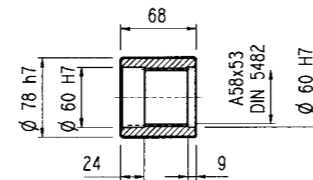

MOA

花键棒 Spline Bar

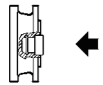

材料: 42CrMo钢表面硬度HRC45-55  
Material: 42CrMo steel surface hardness HRC45-55

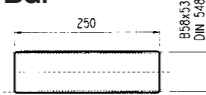

BOA

收缩盘 Shrink Disk

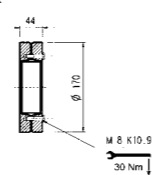
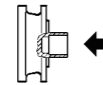

GOA

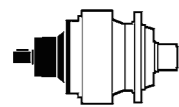

	Input	V	V1	V2	V4	V5	A	B	F	L	S	D	U
EQ304L1	VO5B	239	48	82	155	245	14	9	51.5	70	6	M16	36
	FV05B	276	48	82	219.5	244	14	9	51.5	70	6	M16	36
EQ304L2	VO1A	137.5	24	36	120	186	8	7	27	30	3	M8	19
	VO1B	158	38	58	120	186	10	8	41	50	4	M12	28
EQ304L3	VO1A	137.5	24	36	120	186	8	7	27	30	3	M8	19
	VO1B	158	38	58	120	186	10	8	41	50	4	M12	28
EQ304L4	VO1A	137.5	24	36	120	186	8	7	27	30	3	M8	19
	VO1B	158	38	58	120	186	10	8	41	50	4	M12	28
EQ304R2/3/4	VO1A	137.5	24	36	120	186	8	7	27	30	3	M8	19
	VO1B	158	38	58	120	186	10	8	41	50	4	M12	28

V...

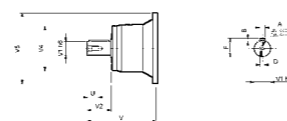

FV...

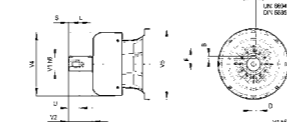

输出轴上的径向载荷位置系数

RADIAL LOAD POSITION COEFFICIENT ON OUTPUT SHAFT

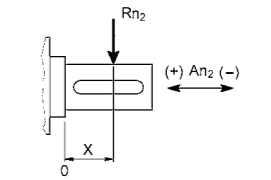
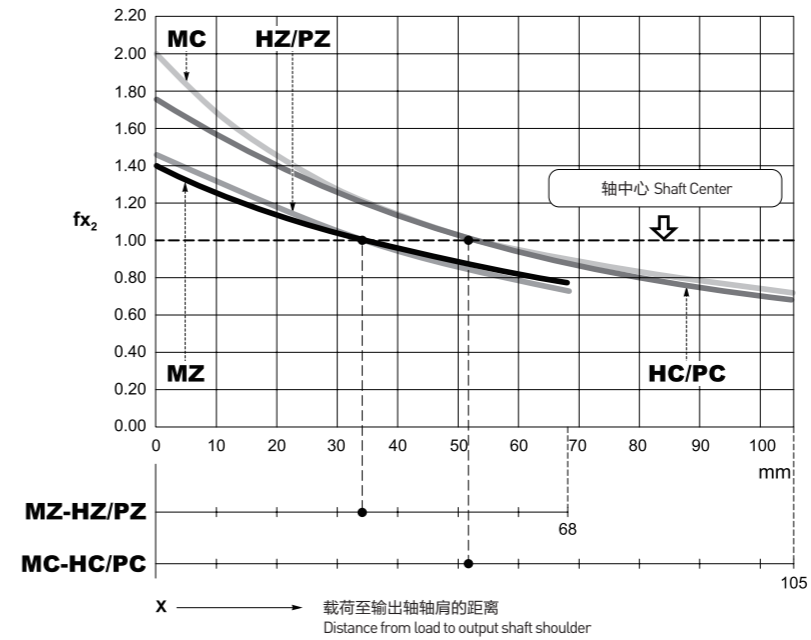

$$R_{x2} = R_{n2} \cdot f_{x2}$$

$$A_{n2}(\pm) = R_{n2} \cdot f_{a2}(\pm)$$

	$f_{a2}(+)$	$f_{a2}(-)$
HZ/PZ	0.74	0.59
HC/PC	0.86	0.69
MC	2.04	2.04
MZ	1.74	1.74

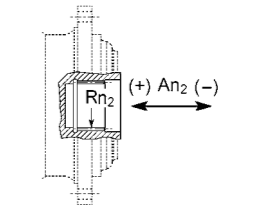

$$A_{n2}(\pm) = R_{n2} \cdot f_{a2}(\pm)$$

	$f_{a2}(+)$	$f_{a2}(-)$
FZ	1.04	1.04

输入转速 $n_1=1000\text{min}^{-1}$ 且假设使用寿命=10000小时, 输入轴上的允许悬臂荷载。

当输入转速和/或使用寿命不同于这里所列举的值时, 参见样本: 校核。

Input speed  $n_1=1000\text{min}^{-1}$  and assuming a service life of 10000 hours, the allowable cantilever load on the input shaft.

When the input speed and/or service life are different from the values listed here, refer to sample: verification.

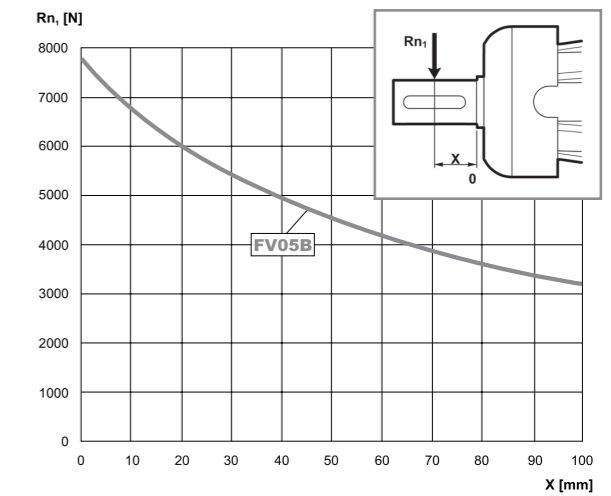
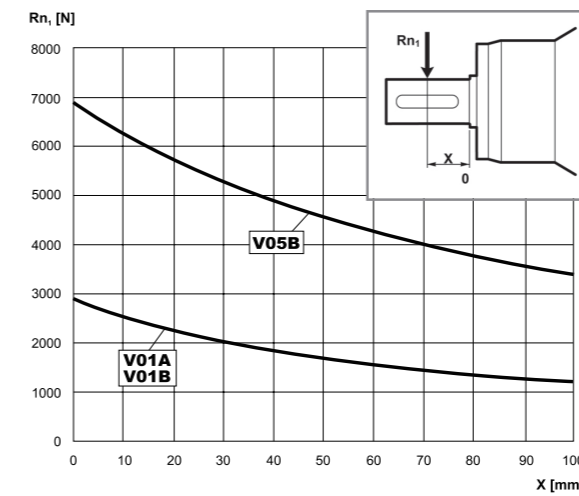

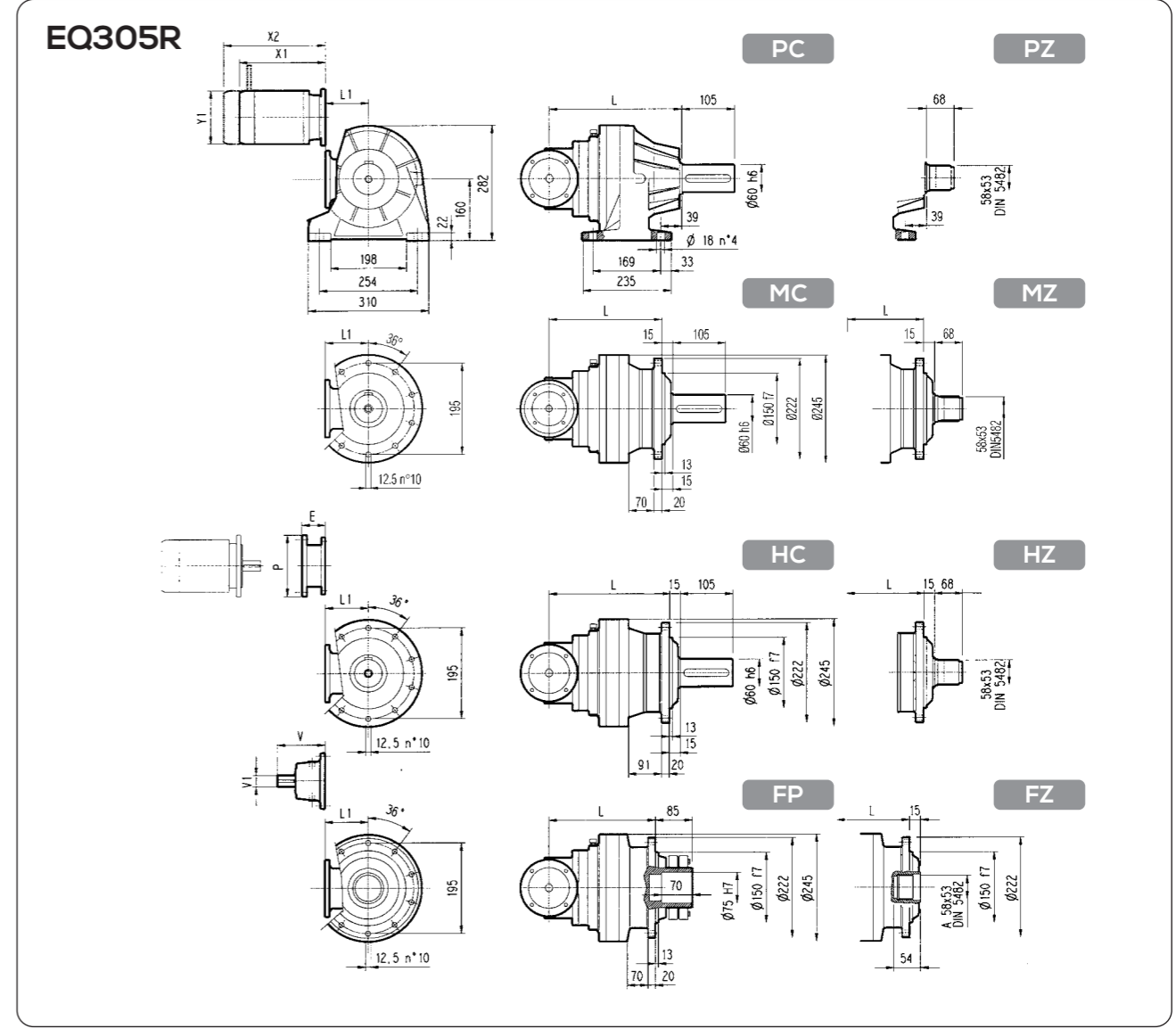
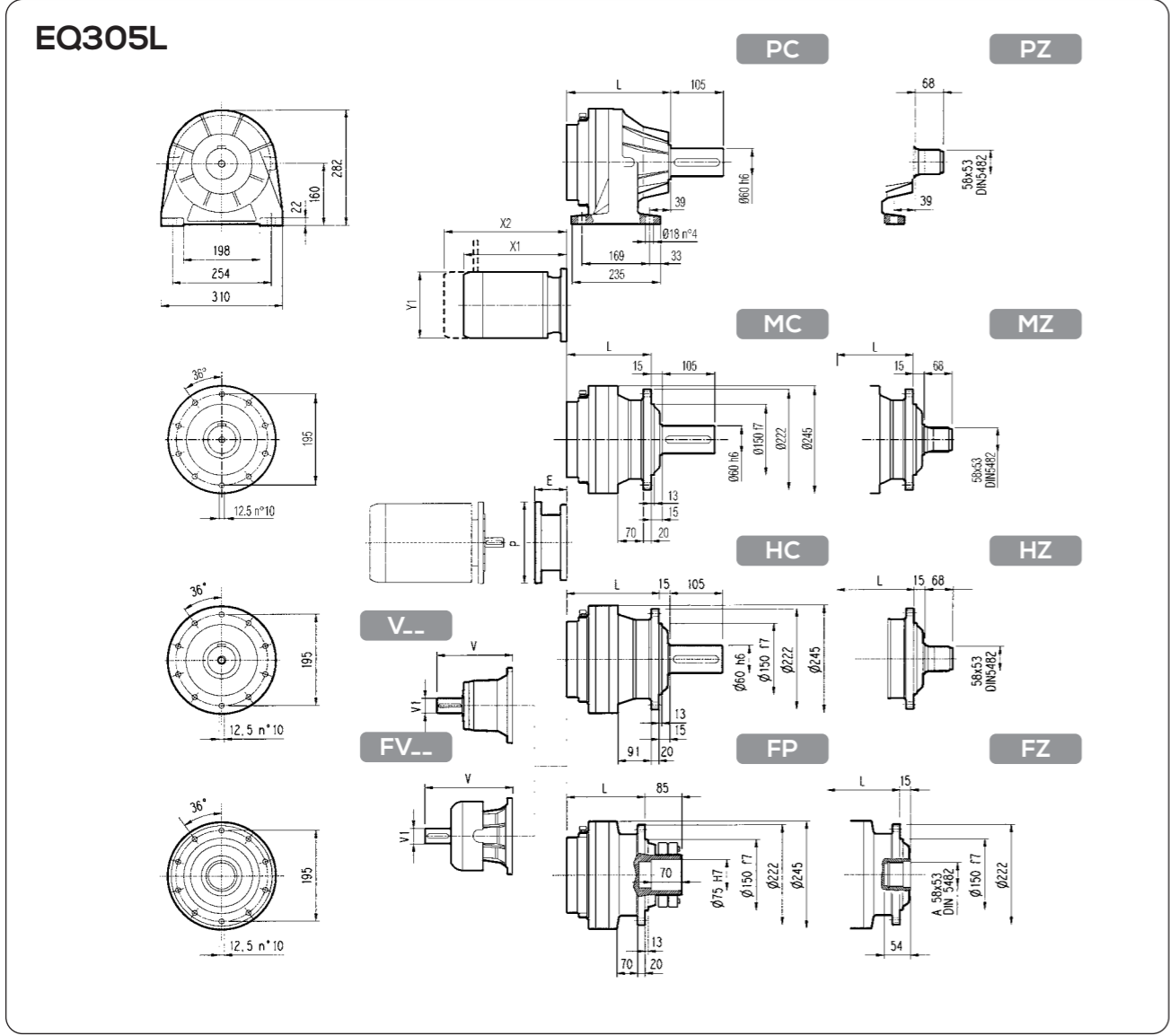
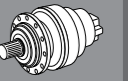
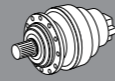

FP  $M_{2max} = 7000 \text{ Nm}$

FP  $M_{2max} = 7000 \text{ Nm}$

	L				Kg				输入轴 Input Shaft				输入轴 Input Shaft					
	MC-MZ	PC-PZ	HC-HZ	FP-FZ	MC-MZ	PC-PZ	HC-HZ	FP-FZ	V	V1	Kg	V	V1	Kg	V	V1	Kg	
EQ305L1	143	183	168	143	36	45	40	36	239	48	15	-	-	276	48	17	-	-
EQ305L2	208	248	233	208	43	52	47	43	137.5	24	6	158	38	7	-	-	-	-
EQ305L3	261	301	286	261	47	56	51	47	137.5	24	6	158	38	7	-	-	-	-
EQ305L4	314	354	339	314	51	60	55	51	137.5	24	6	158	38	7	-	-	-	-

	L				L1	Kg				输入轴 Input Shaft					
	MC-MZ	PC-PZ	HC-HZ	FP-FZ		MC-MZ	PC-PZ	HC-HZ	FP-FZ	V	V1	Kg	V	V1	Kg
EQ305R2	235	375	260	235	140	56	65	60	56	137.5	24	6	158	38	7
EQ305R3	300	340	325	300	122	57	57	61	57	137.5	24	6	158	38	7
EQ305R4	353	393	378	353	122	61	61	65	61	137.5	24	6	158	38	7

	P71		P80		P90		P100		P112		P132		P160		P180		P200	
	E	P	E	P	E	P	E	P	E	P	E	P	E	P	E	P	E	P
EQ305L1	-	-	-	-	-	-	-	-	-	-	114	300	144	350	144	350	174	400
EQ305L2	65	160	84	200	84	200	94	250	94	250	114	300	144	350	-	-	-	-
EQ305L3	65	160	84	200	84	200	94	250	94	250	114	300	144	350	-	-	-	-
EQ305L4	65	160	84	200	84	200	94	250	94	250	114	300	144	350	-	-	-	-

	P71		P80		P90		P100		P112		P132	
	E	P	E	P	E	P	E	P	E	P	E	P
EQ305R2	65	160	84	200	84	200	94	250	94	250	114	300
EQ305R3	65	160	84	200	84	200	94	250	94	250	114	300
EQ305R4	65	160	84	200	84	200	94	250	94	250	114	300

	S1+M1S			S1+M1L			S2+M2S			S3+M3S			S3+M3L			S4+M4			S5+M5S			S5+M5L		
	X1	X2	Y1	X1	X2	Y1	X1	X2	Y1	X1	X2	Y1	X1	X2	Y1	X1	X2	Y1	X1	X2	Y1	X1	X2	Y1
EQ305L1	-	-	-	-	-	-	-	-	-	-	-	-	-	-	-	460	571	258	552	692	310	596	736	310
EQ305L2	-	-	-	-	-	-	-	-	-	-	-	-	-	-	-	460	571	258	-	-	-	-	-	-
EQ305L3	229	292	138	253	314	138	280	352	156	325	421	195	357	449	195	460	571	258	-	-	-	-	-	-
EQ305L4	229	292	138	253	314	138	280	352	156	325	421	195	357	449	195	460	571	258	-	-	-	-	-	-

	S1+M1S			S1+M1L			S2+M2S			S3+M3S			S3+M3L			S4+M4					
	X1	X2	Y1	X1	X2	Y1	X1	X2	Y1	X1	X2	Y1	X1	X2	Y1	X1	X2	Y1			
EQ305R2	-	-	-	-	-	-	-	-	-	328	400	156	373	469	195	405	497	195	508	619	258
EQ305R3	229	292	138	253	314	138	280	352	156	325	421	195	357	449	195	405	497	195	508	619	258
EQ305R4	229	292	138	253	314	138	280	352	156	325	421	195	357	449	195	405	497	195	508	619	258

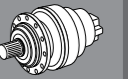
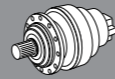

EQ305L / ER305R

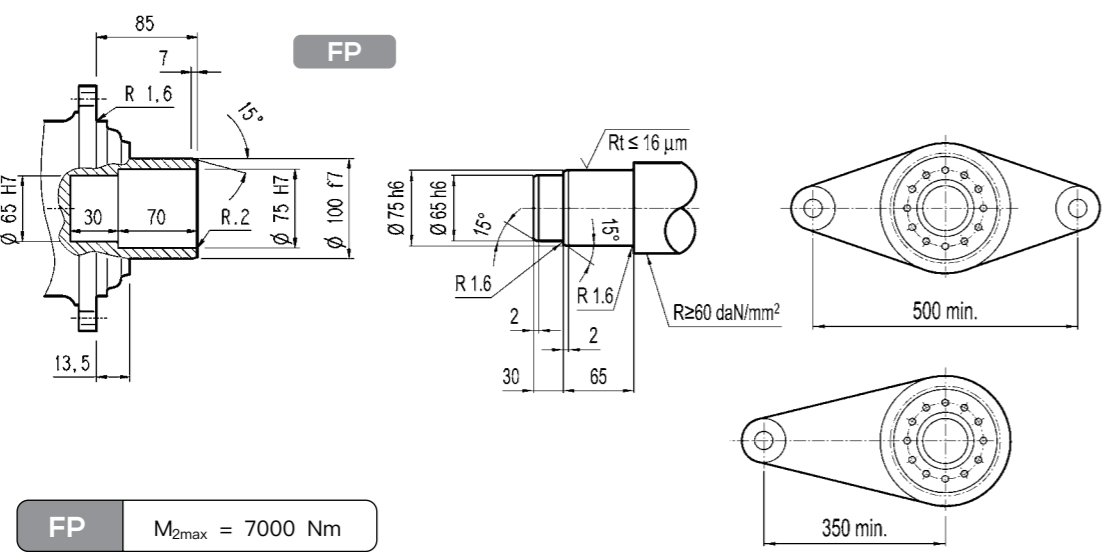
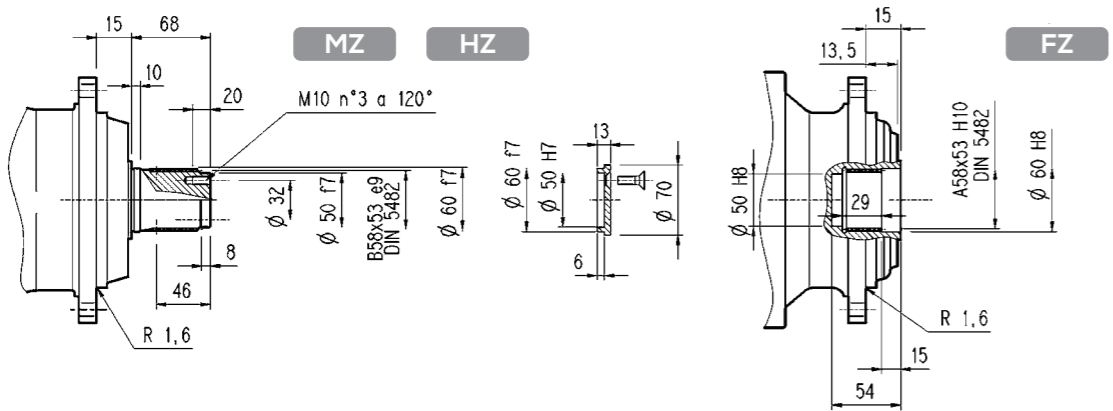
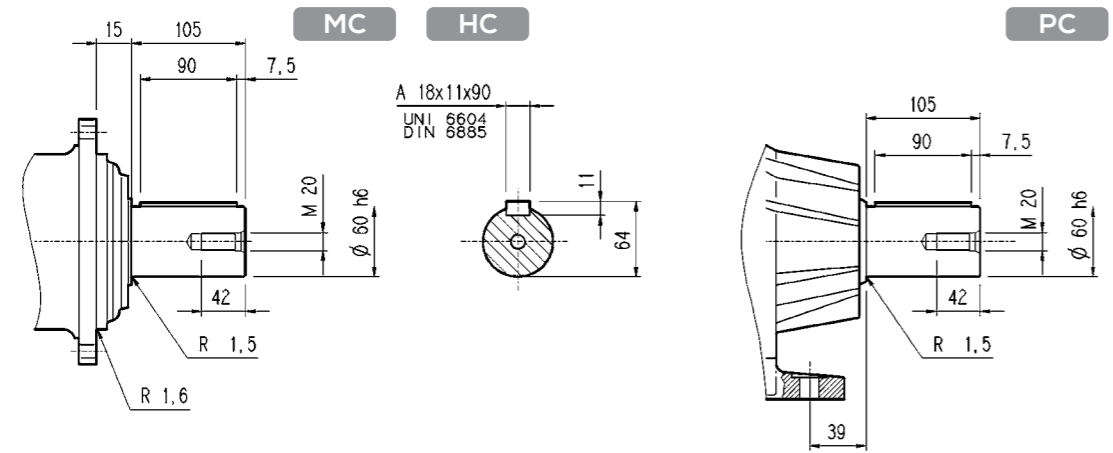

FP M<sub>2max</sub> = 7000 Nm

法兰 Flange

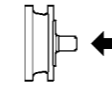

材料: 45#钢  
Material: 45 # steel

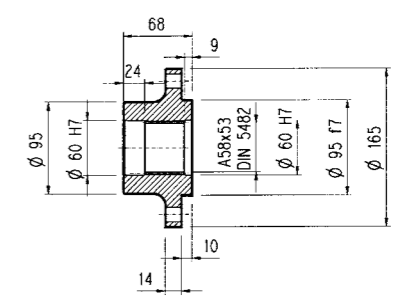
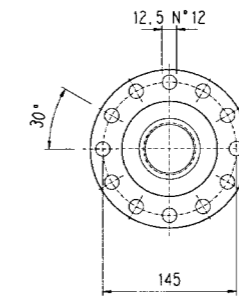

WOA

小齿轮 Pinion



	m	z	x	dp	di	de	H	A	B	C	☆
PCL1	5	19	0	95	82	104	77	12	9	72	□
PCL2	5	19	0	95	82	104	68	0	0	0	□
PCM	5	20	0	100	87.5	110	68	18	0	0	■
PCP	5	22	0	110	97.5	120	68	18	0	0	■
PDE	6	14	0.500	84	75	99.6	68	0	0	0	□
PDI	6	18	0.500	108	99	123.6	68	0	0	0	□
PDM	6	20	0.833	120	115	140	68	0	0	0	□
PFD	8	13	0.675	104	95	127.6	68	0	0	0	■
PFE1	8	14	0	112	92	126	68	0	0	0	■
PFE2	8	14	0	112	92	126	80	0	12	72	■
PFF	8	15	0	120	100	136	68	0	0	0	□
PFP	8	22	0	176	156	190	77	12	10	71	□
PHG	10	16	0.500	160	145	188	75	0	7	72	□

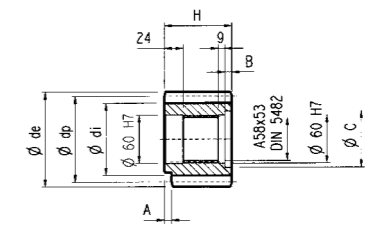

☆ 材料 Material  
□ 42CrMo钢调质 42CrMo steel quenched and tempered  
■ 20CrMnTi钢表面渗碳 Surface carburizing of 20CrMnTi steel

套筒联轴节 Sleeve Coupling



材料: 42CrMo钢  
Material: 42CrMo steel

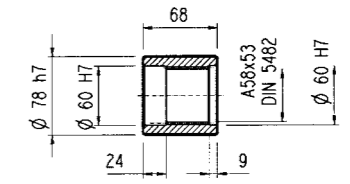

MOA

花键棒 Spline Bar

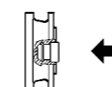

材料: 42CrMo钢表面硬度HRC45-55  
Material: 42CrMo steel surface hardness HRC45-55

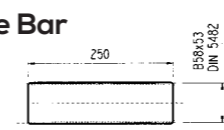

BOA

收缩盘 Shrink Disk

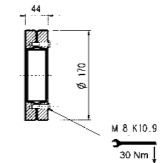
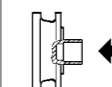

GOA

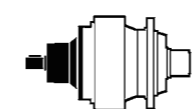

	Input	V	V1	V2	V4	V5	A	B	F	L	S	D	U
EQ305L1	VO5B	239	48	82	155	245	14	9	51.5	70	6	M16	36
	FV05B	276	48	82	219.5	244	14	9	51.5	70	6	M16	36
EQ305L2	VO1A	137.5	24	36	120	186	8	7	27	30	3	M8	19
	VO1B	158	38	58	120	186	10	8	41	50	4	M12	28
EQ305L3	VO1A	137.5	24	36	120	186	8	7	27	30	3	M8	19
	VO1B	158	38	58	120	186	10	8	41	50	4	M12	28
EQ305L4	VO1A	137.5	24	36	120	186	8	7	27	30	3	M8	19
	VO1B	158	38	58	120	186	10	8	41	50	4	M12	28
EQ305R2/3/4	VO1A	137.5	24	36	120	186	8	7	27	30	3	M8	19
	VO1B	158	38	58	120	186	10	8	41	50	4	M12	28

V..

FV..

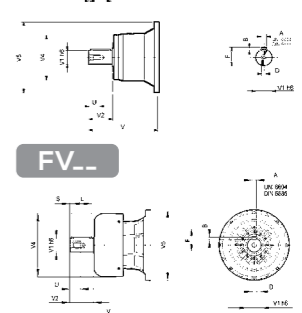

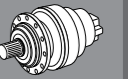
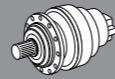

输出轴上的径向载荷位置系数  
RADIAL LOAD POSITION COEFFICIENT ON OUTPUT SHAFT

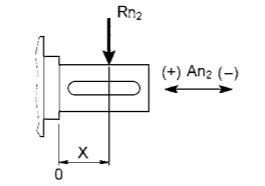
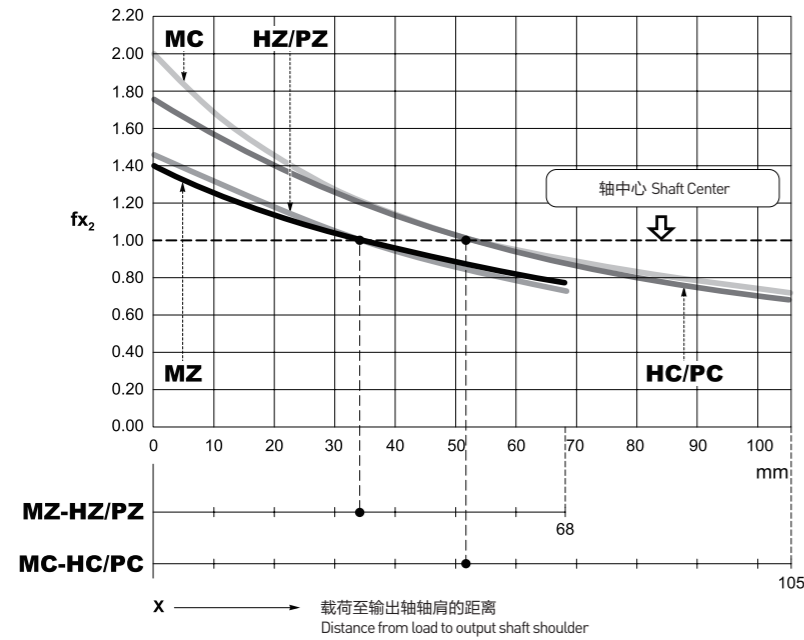

$R_{v2} = R_{n2} \cdot f_{x2}$

$An_2 (\pm) = R_{n2} \cdot fa_2 (\pm)$

	$fa_2 (+)$	$fa_2 (-)$
HZ/PZ	0.74	0.59
HC/PC	0.86	0.69
MC	2.04	2.04
MZ	1.74	1.74

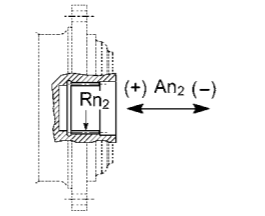

$An_2 (\pm) = R_{n2} \cdot fa_2 (\pm)$

	$fa_2 (+)$	$fa_2 (-)$
FZ	1.04	1.04

输入转速 $n_1=1000\text{min}^{-1}$ 且假设使用寿命=10000小时, 输入轴上的允许悬臂荷载。  
当输入转速和/或使用寿命不同于这里所列举的值时, 参见样本: 校核。  
Input speed  $n_1=1000\text{min}^{-1}$  and assuming a service life of 10000 hours, the allowable cantilever load on the input shaft.  
When the input speed and/or service life are different from the values listed here, refer to sample: verification.

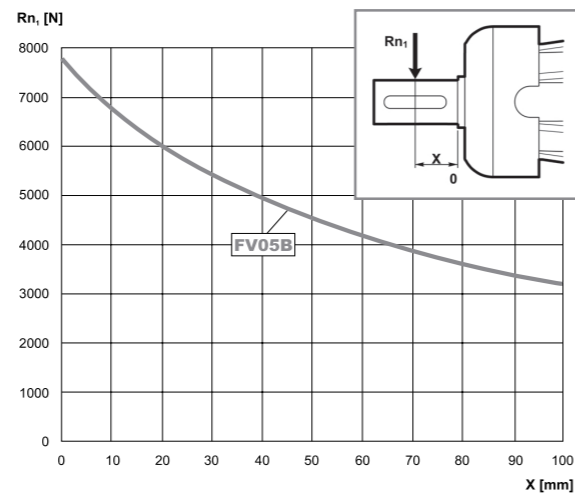
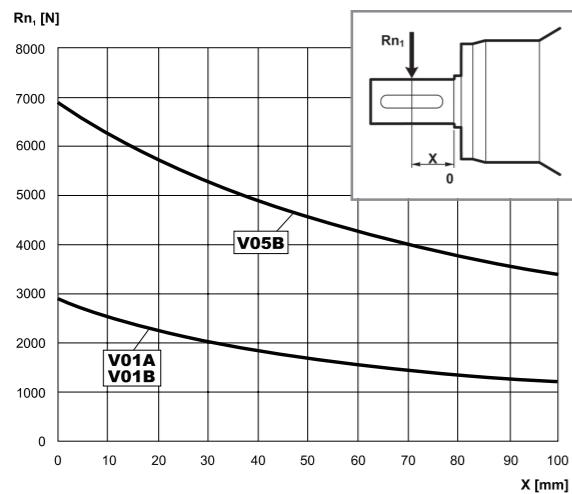

EQ306L

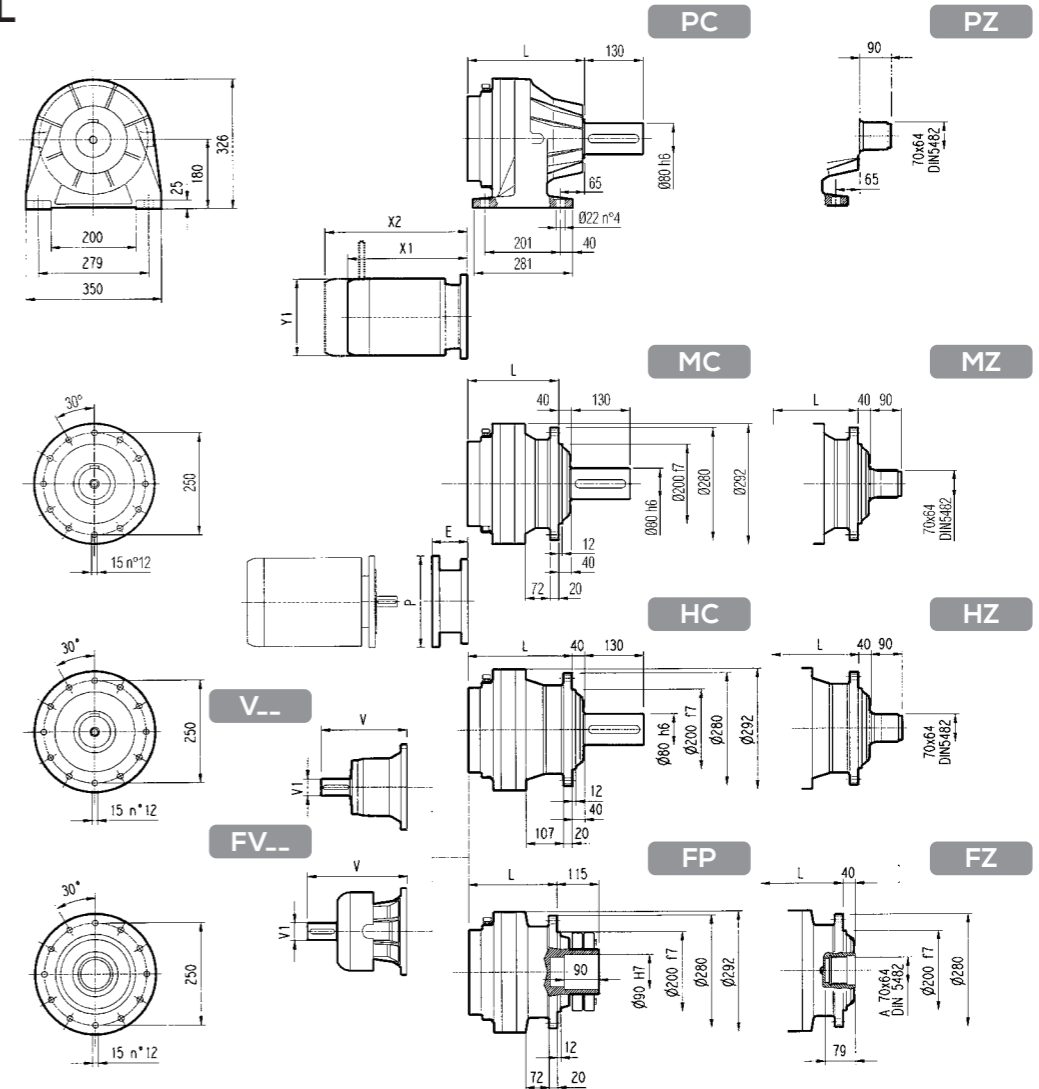

FP  $M_{2max} = 12000 \text{ Nm}$

	L				Kg				输入轴 Input Shaft				输入轴 Input Shaft					
	MC-MZ	PC-PZ	HC-HZ	FP-FZ	MC-MZ	PC-PZ	HC-HZ	FP-FZ	V	V1	Kg	V	V1	Kg	V	V1	Kg	
EQ306L1	160	235	195	160	65	85	70	65	307	60	23	-	-	357	60	28	-	-
EQ306L2	225	300	260	225	74	95	79	74	239	48	15	-	-	276	48	17	-	-
EQ306L3	278	353	313	278	78	98	83	83	137.5	24	6	158	38	7	-	-	-	-
EQ306L4	331	406	366	331	82	103	87	87	137.5	24	6	158	38	7	-	-	-	-

	P71		P80		P90		P100		P112		P132		P160		P180		P200		P225		P250	
	E	P	E	P	E	P	E	P	E	P	E	P	E	P	E	P	E	P	E	P	E	P
EQ306L1	-	-	-	-	-	-	-	-	-	-	-	-	144	350	153	350	183	400	212	450	193	550
EQ306L2	-	-	-	-	-	-	-	-	-	-	114	300	144	350	144	350	174	400	-	-	-	-
EQ306L3	65	160	84	200	84	200	94	250	94	250	114	300	144	350	-	-	-	-	-	-	-	-
EQ306L4	65	160	84	200	84	200	94	250	94	250	114	300	144	350	-	-	-	-	-	-	-	-

	S1+M1S			S1+M1L			S2+M2S			S3+M3S			S3+M3L			S4+M4			S5+M5S			S5+M5L		
	X1	X2	Y1	X1	X2	Y1	X1	X2	Y1	X1	X2	Y1	X1	X2	Y1	X1	X2	Y1	X1	X2	Y1	X1	X2	Y1
EQ306L1	-	-	-	-	-	-	-	-	-	-	-	-	-	-	-	-	-	-	-	-	-	-	-	-
EQ306L2	-	-	-	-	-	-	-	-	-	-	-	-	-	-	-	460	571	258	552	692	310	596	736	310
EQ306L3	229	292	138	253	314	138	280	352	156	325	421	195	357	449	195	460	571	258	-	-	-	-	-	-
EQ306L4	229	292	138	253	314	138	280	352	156	325	421	195	357	449	195	460	571	258	-	-	-	-	-	-

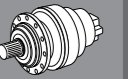
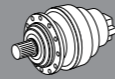

EQ306R

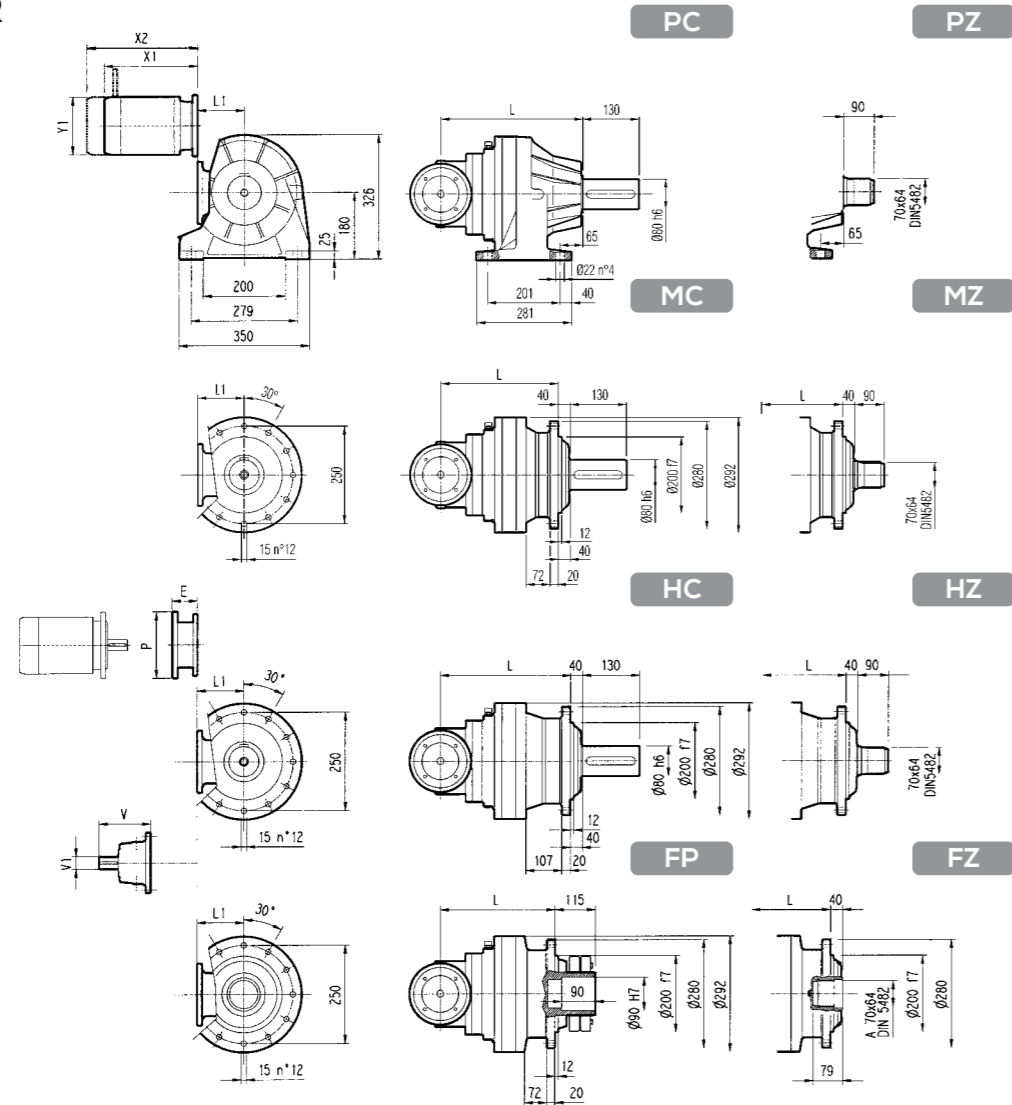

EQ306L / ER306R

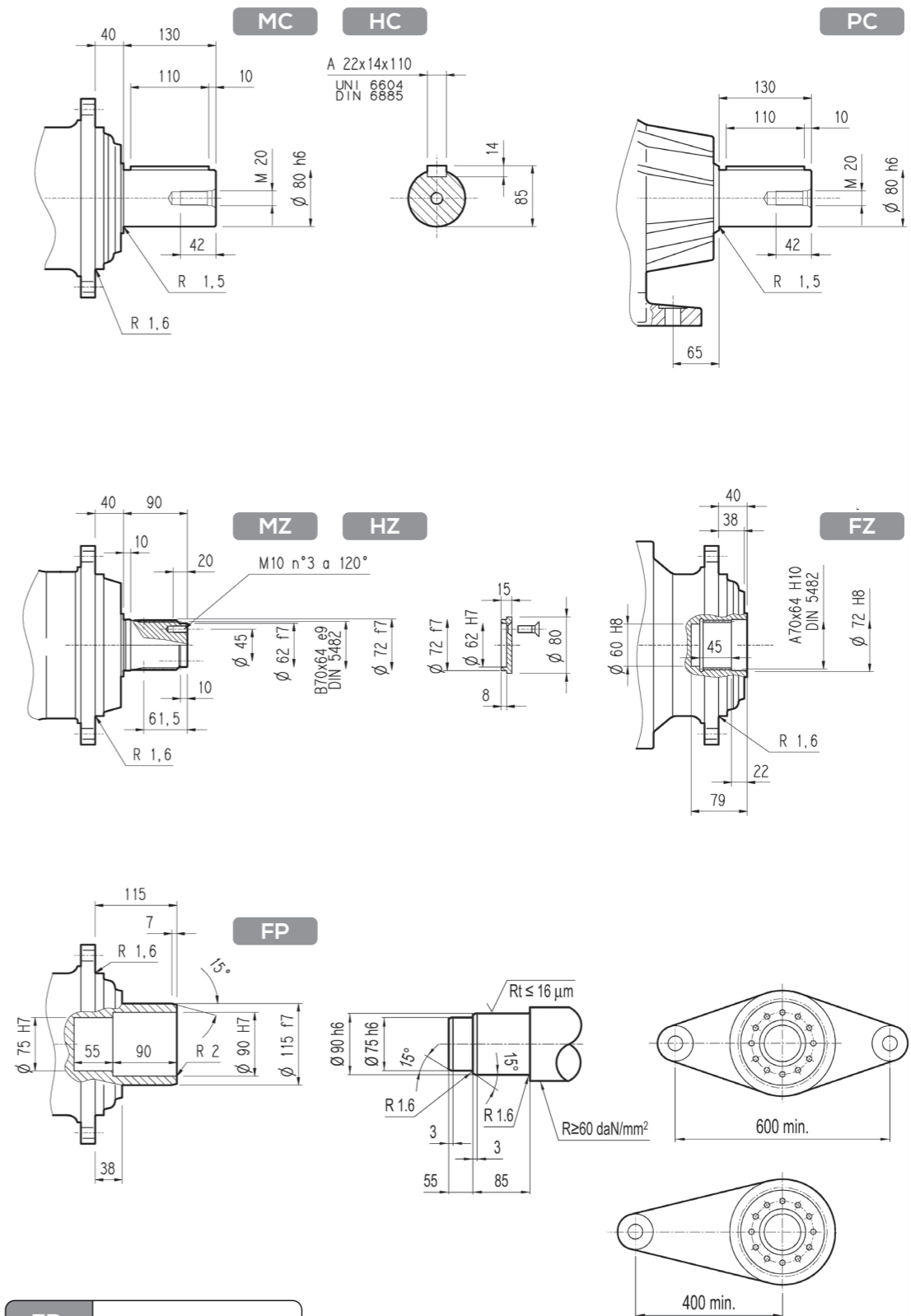

FP  $M_{2max} = 12000 \text{ Nm}$

	L				L1	$K_g$				输入轴 Input Shaft					
	MC-MZ	PC-PZ	HC-HZ	FP-FZ		MC-MZ	PC-PZ	HC-HZ	FP-FZ	V	V1	$K_g$	V	V1	$K_g$
EQ306R2	297	372	332	297	140	89	105	94	89	137.5	24	6	158	38	7
EQ306R3	317	392	352	317	140	85	100	90	85	137.5	24	6	158	38	7
EQ306R4	370	445	405	370	122	79	95	84	79	137.5	24	6	158	38	7

	P71		P80		P90		P100		P112		P132		P160	
	E	P	E	P	E	P	E	P	E	P	E	P	E	P
EQ306R2	65	160	84	200	84	200	94	250	94	250	114	300	144	350
EQ306R3	65	160	84	200	84	200	94	250	94	250	114	300	144	350
EQ306R4	65	160	84	200	84	200	94	250	94	250	114	300	144	350

	S1+M1S			S1+M1L			S2+M2S			S3+M3S			S3+M3L			S4+M4		
	X1	X2	Y1	X1	X2	Y1	X1	X2	Y1	X1	X2	Y1	X1	X2	Y1	X1	X2	Y1
EQ306R2	-	-	-	-	-	-	328	400	156	373	469	195	405	497	195	508	619	258
EQ306R3	229	292	138	253	314	138	328	400	156	373	469	195	405	497	195	508	619	258
EQ306R4	229	292	138	253	314	138	328	400	156	373	469	195	405	497	195	508	619	258

FP  $M_{2max} = 12000 \text{ Nm}$

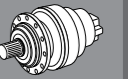
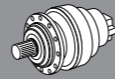

法兰 Flange

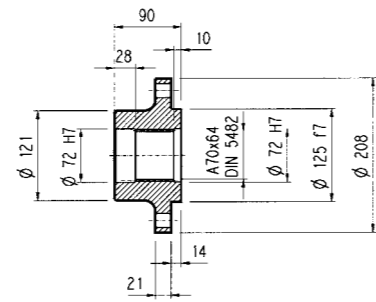
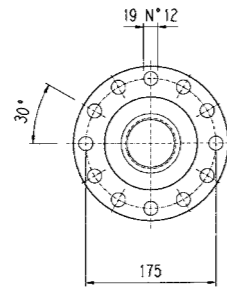
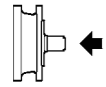

WOA

材料: 45#钢  
Material: 45 # steel

小齿轮 Pinion



	m	z	x	dp	di	de	H	A	B	C	☆
PCL1	8	15	0	120	100	134	90	0	0	0	□
PCL2	8	15	0.500	120	108	141	90	0	0	0	□
PCM	10	11	0.500	110	95	136	90	10	0	0	□
PCP	10	12	0.450	120	104	145	90	0	0	0	□
PDE	10	12	0.320	120	100	144.2	90	0	0	0	□
PDI	10	12	0.350	120	101	144	90	0	0	0	□
PDM	10	13	0.950	130	124	165	90	0	0	0	□
PFD	10	13	0.500	130	115	159	90	0	0	0	□
PFE1	10	14	0	140	115	160	90	0	0	0	□
PFE2	10	14	0.500	140	125	166	90	0	0	0	■
PFF	10	15	0	150	127	167	90	24	0	0	□
PFP	10	17	0.480	170	154	197.5	90	10	0	0	□
PHG	10	20	0	200	175	220	90	10	0	0	■

☆ 材料 Material  
□ 42CrMo钢调质 42CrMo steel quenched and tempered  
■ 20CrMnTi钢表面渗碳 Surface carburizing of 20CrMnTi steel

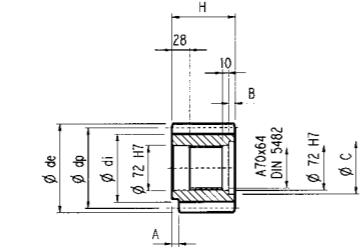

P...

套筒联轴节 Sleeve Coupling



材料: 42CrMo钢  
Material: 42CrMo steel

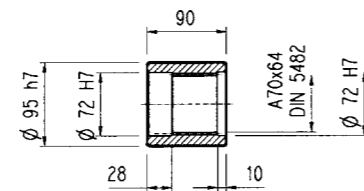

MOA

花键棒 Spline Bar

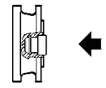

材料: 42CrMo钢表面硬度HRC45-55  
Material: 42CrMo steel surface hardness HRC45-55

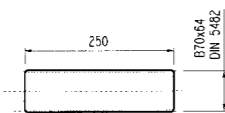

BOA

收缩盘 Shrink Disk

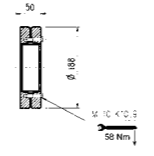
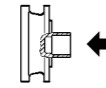

GOA

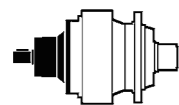

	Input	V	V1	V2	V4	V5	A	B	F	L	S	D	U
EQ306L1	VO6B	307	60	105	155	292	18	11	64	90	7.5	M16	36
	FV06B	357	60	105	309	292	18	11	64	90	7.5	M16	36
EQ306L2	VO5B	239	48	82	155	245	14	9	51.5	70	6	M16	36
	VO5B	276	48	82	219.5	244	14	9	51.5	70	6	M16	36
EQ306L3	VO1A	137.5	24	36	120	186	8	7	27	30	3	M8	19
	VO1B	158	38	58	120	186	10	8	41	50	4	M12	28
EQ306L4	VO1A	137.5	24	36	120	186	8	7	27	30	3	M8	19
	VO1B	158	38	58	120	186	10	8	41	50	4	M12	28
EQ306R2/3/4	VO1A	137.5	24	36	120	186	8	7	27	30	3	M8	19
	VO1B	158	38	58	120	186	10	8	41	50	4	M12	28

V...

FV...

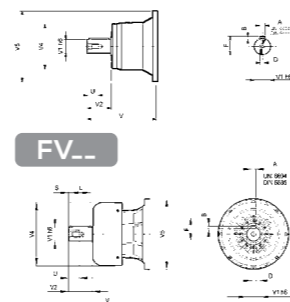

输出轴上的径向载荷位置系数

RADIAL LOAD POSITION COEFFICIENT ON OUTPUT SHAFT

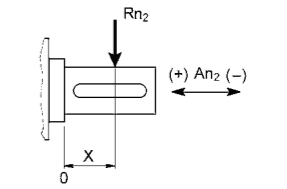
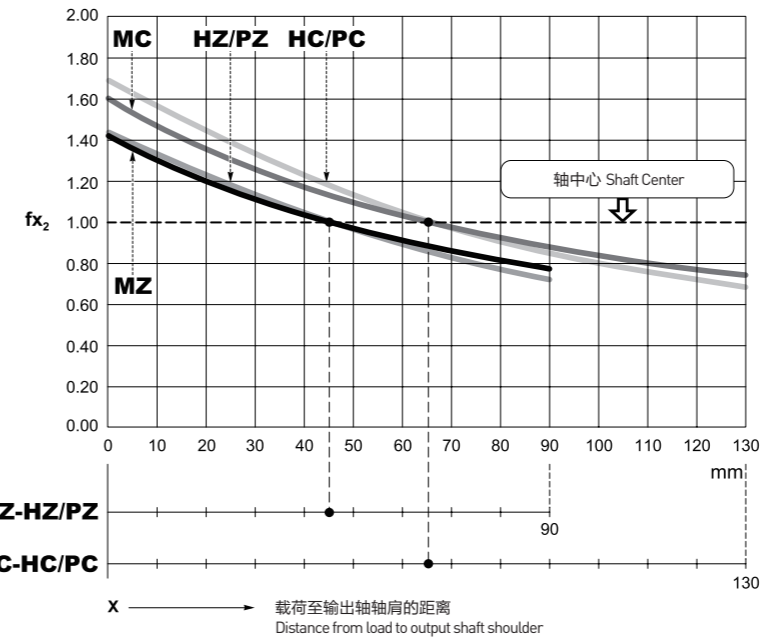

$$R_{x2} = R_{n2} \cdot f_{x2}$$

$$A_{n2} (\pm) = R_{n2} \cdot f_{a2} (\pm)$$

	$f_{a2} (+)$	$f_{a2} (-)$
HZ/PZ	1.01	0.50
HC/PC	1.19	0.59
MC	2.14	2.14
MZ	1.89	1.89

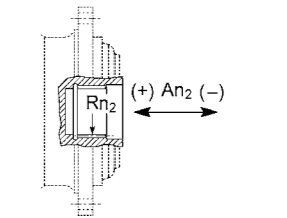

$$A_{n2} (\pm) = R_{n2} \cdot f_{a2} (\pm)$$

	$f_{a2} (+)$	$f_{a2} (-)$
FZ	1.00	1.00

输入转速 $n_1=1000\text{min}^{-1}$ 且假设使用寿命=10000小时, 输入轴上的允许悬臂荷载。

当输入转速和/或使用寿命不同于这里所列举的值时, 参见样本: 校核。

Input speed  $n_1=1000\text{min}^{-1}$  and assuming a service life of 10000 hours, the allowable cantilever load on the input shaft.

When the input speed and/or service life are different from the values listed here, refer to sample: verification.

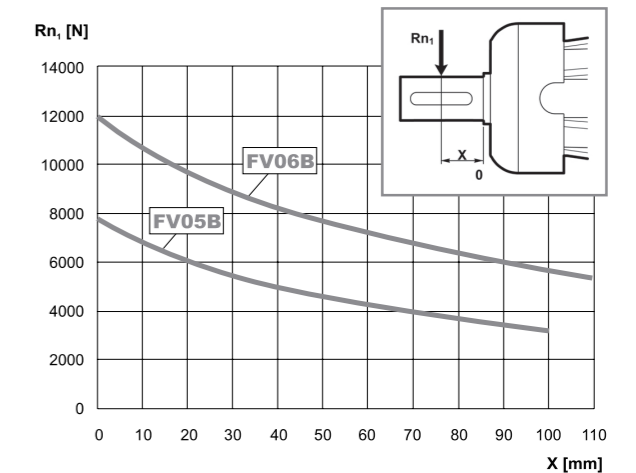
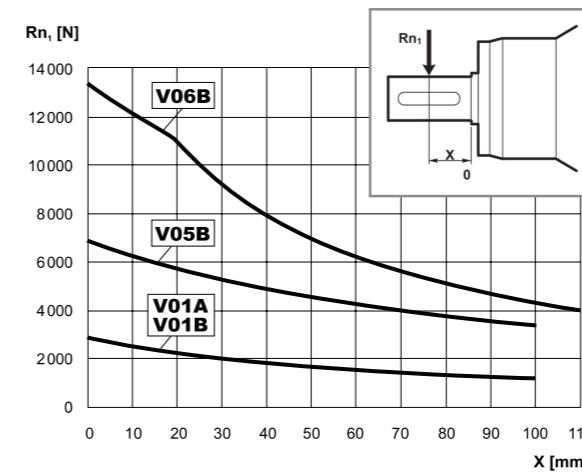

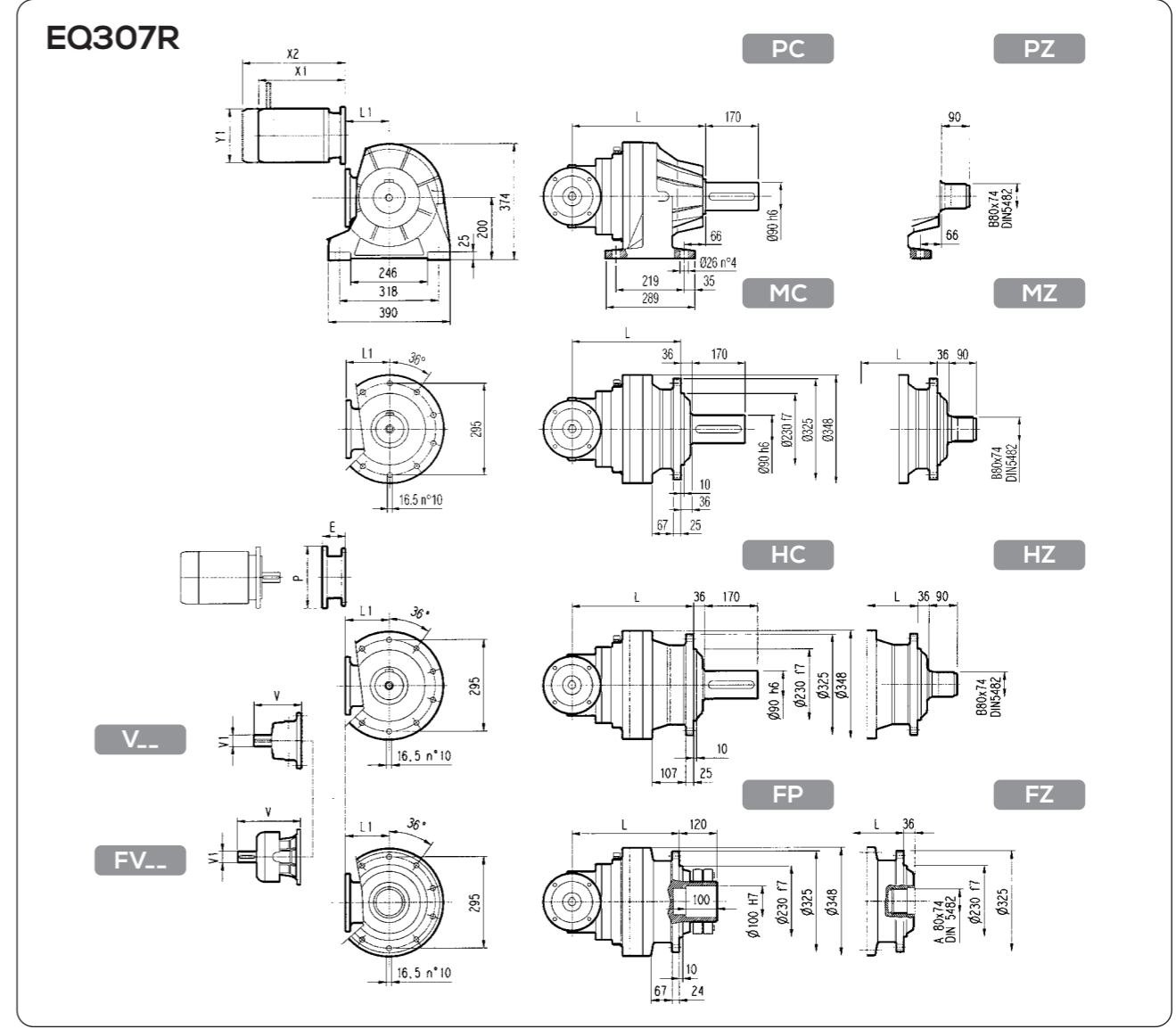
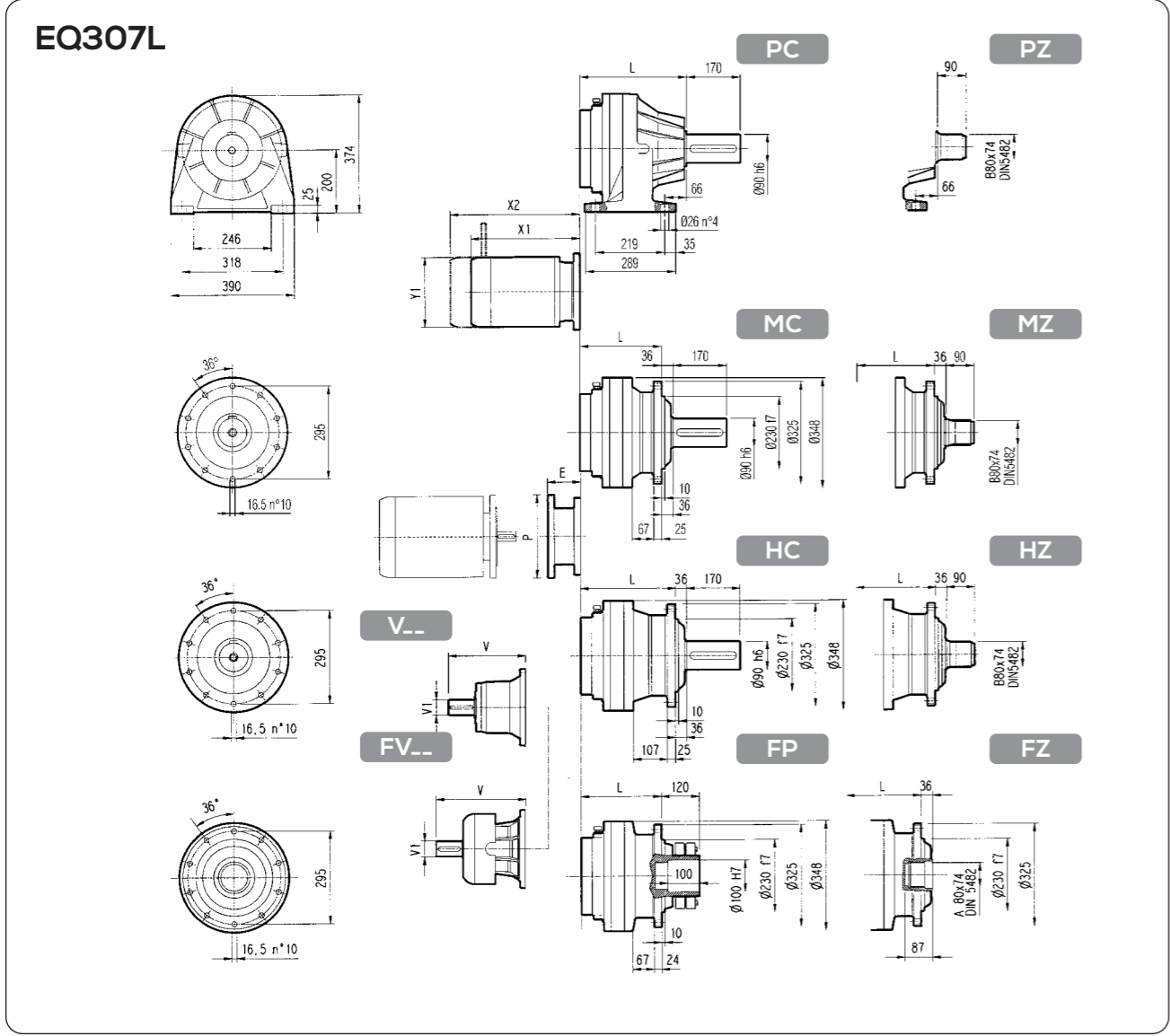
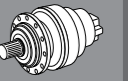
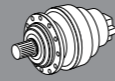

FP  $M_{2max} = 18000 \text{ Nm}$

FP  $M_{2max} = 18000 \text{ Nm}$

	L				Kg				输入轴 Input Shaft				输入轴 Input Shaft							
	MC-MZ	PC-PZ	HC-HZ	FP-FZ	MC-MZ	PC-PZ	HC-HZ	FP-FZ	V	V1	Kg	V	V1	Kg	V	V1	Kg			
EQ307L1	165	246	210	165	85	120	105	85	315	80	35	313	60	28	357	80	48	363	60	34
EQ307L2	254	335	299	254	97	132	117	97	239	48	15	-	-	-	276	48	17	-	-	-
EQ307L3	319	400	364	319	104	139	124	104	137.5	24	6	158	38	7	-	-	-	-	-	-
EQ307L4	372	453	417	372	108	143	128	108	137.5	24	6	158	38	7	-	-	-	-	-	-

	L				L1	Kg				输入轴 Input Shaft				输入轴 Input Shaft						
	MC-MZ	PC-PZ	HC-HZ	FP-FZ		MC-MZ	PC-PZ	HC-HZ	FP-FZ	V	V1	Kg	V	V1	Kg	V	V1	Kg		
EQ307R2	284	365	329	284	225	135	170	155	135	239	48	15	-	38	7	276	48	17	-	-
EQ307R3	346	427	391	346	140	117	152	137	117	137.5	24	6	158	38	7	-	-	-	-	-
EQ307R4	411	492	456	411	122	118	153	138	118	137.5	24	6	158	38	7	-	-	-	-	-

	P71		P80		P90		P100		P112		P132		P160		P180		P200		P225		P250	
	E	P	E	P	E	P	E	P	E	P	E	P	E	P	E	P	E	P	E	P	E	P
EQ307L1	-	-	-	-	-	-	-	-	-	-	-	-	144	350	195	350	186	400	216	450	215	550
EQ307L2	-	-	-	-	-	-	-	-	-	-	114	300	144	350	144	350	174	400	-	-	-	-
EQ307L3	65	160	84	200	84	200	94	250	94	250	114	300	144	350	-	-	-	-	-	-	-	
EQ307L4	65	160	84	200	84	200	94	250	94	250	114	300	144	350	-	-	-	-	-	-	-	

	P71		P80		P90		P100		P112		P132		P160		P180		P200	
	E	P	E	P	E	P	E	P	E	P	E	P	E	P	E	P	E	P
EQ307R2	-	-	-	-	-	-	-	-	-	-	114	300	144	350	144	350	174	400
EQ307R3	65	160	84	200	84	200	94	250	94	250	114	300	144	350	-	-	-	-
EQ307R4	65	160	84	200	84	200	94	250	94	250	114	300	144	350	-	-	-	-

	S1+M1S			S1+M1L			S2+M2S			S3+M3S			S3+M3L			S4+M4			S5+M5S			S5+M5L		
	X1	X2	Y1	X1	X2	Y1	X1	X2	Y1	X1	X2	Y1	X1	X2	Y1	X1	X2	Y1	X1	X2	Y1	X1	X2	Y1
EQ307L1	-	-	-	-	-	-	-	-	-	-	-	-	-	-	-	-	-	-	-	-	-	-	-	-
EQ307L2	-	-	-	-	-	-	-	-	-	-	-	-	-	-	-	460	571	258	552	692	310	596	736	310
EQ307L3	-	-	-	-	-	-	280	352	156	325	421	195	357	449	195	460	571	258	-	-	-	-	-	-
EQ307L4	229	292	138	253	314	138	280	352	156	325	421	195	357	449	195	460	571	258	-	-	-	-	-	-

	S1+M1S			S1+M1L			S2+M2S			S3+M3S			S3+M3L			S4+M4			S5+M5S			S5+M5L		
	X1	X2	Y1	X1	X2	Y1	X1	X2	Y1	X1	X2	Y1	X1	X2	Y1	X1	X2	Y1	X1	X2	Y1	X1	X2	Y1
EQ307R2	-	-	-	-	-	-	-	-	-	-	-	-	-	-	-	508	619	258	552	692	310	596	736	310
EQ307R3	229	292	138	253	314	138	229	292	138	253	314	138	229	292	138	229	292	138	229	292	138	229	292	138
EQ307R4	229	292	138	253	314	138	229	292	138	253	314	138	229	292	138	229	292	138	229	292	138	229	292	138

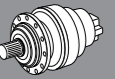
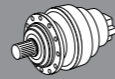

EQ307L / ER307R

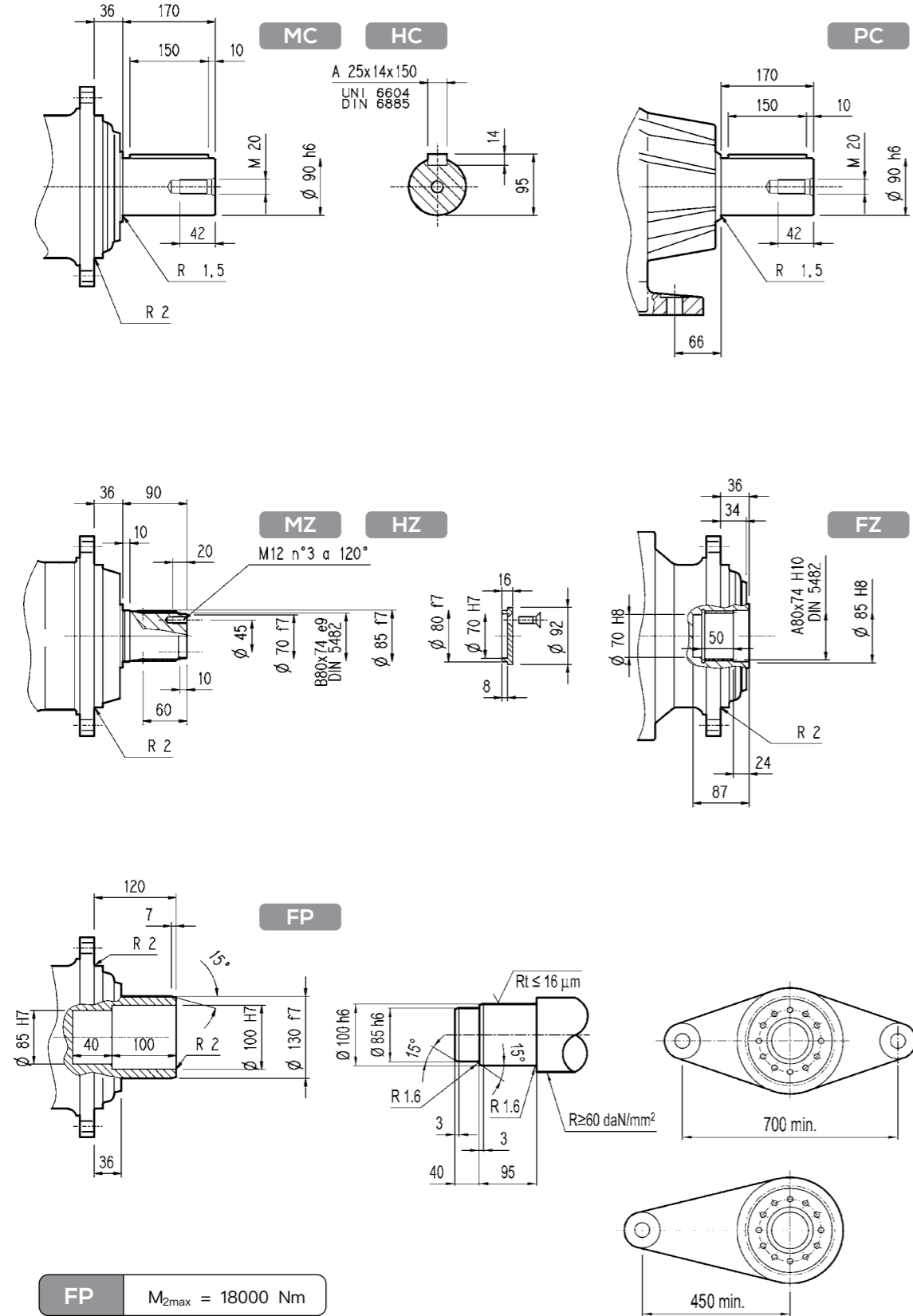

法兰 Flange

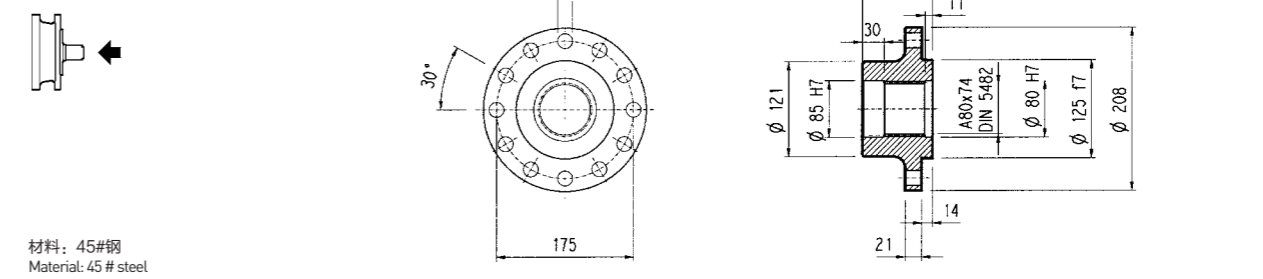

小齿轮 Pinion

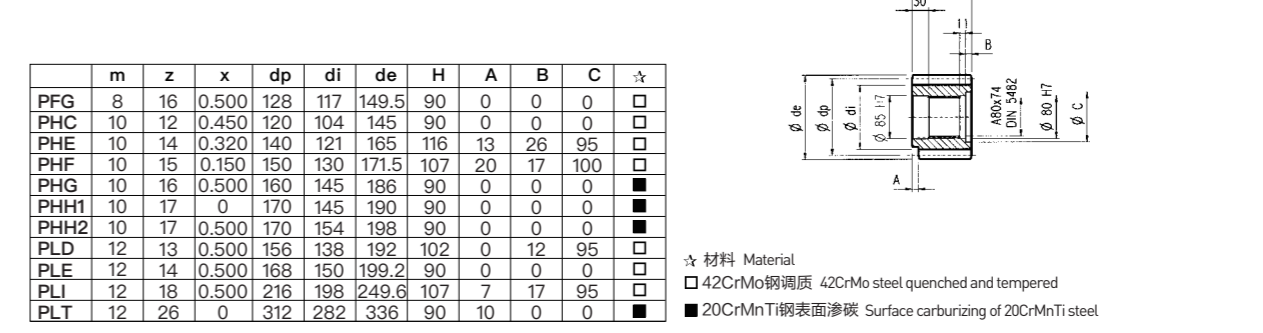

套筒联轴节 Sleeve Coupling



花键棒 Spline Bar

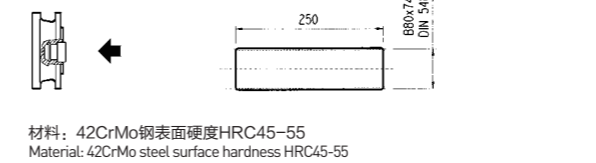

收缩盘 Shrink Disk

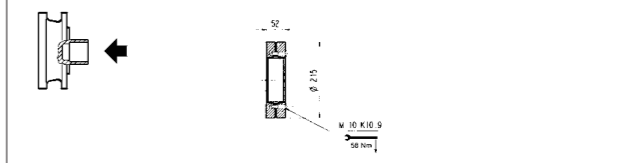

	Input	V	V1	V2	V4	V5	A	B	F	L	S	D	U
EQ307L1	VO7B	315	80	130	200	345	22	14	85	110	10	M16	36
	FV07B	375	80	130	347.5	348	22	14	85	110	10	M16	36
	VO7A	313	60	105	155	345	18	11	64	90	7.5	M16	36
EQ307L2	FV07A	363	60	105	309	348	18	11	64	90	7.5	M16	36
	V05B	239	48	82	155	245	14	9	51.5	70	6	M16	36
	FV05B	276	48	82	219.5	244	14	9	51.5	70	6	M16	36
EQ307L3	VO1A	137.5	24	36	120	186	8	7	27	30	3	M8	19
	VO1B	158	38	58	120	186	10	8	41	50	4	M12	28
	VO1A	137.5	24	36	120	186	8	7	27	30	3	M8	19
EQ307L4	VO1B	158	38	58	120	186	10	8	41	50	4	M12	28
	V05B	239	48	82	155	245	14	9	51.5	70	6	M16	36
	FV05B	276	48	82	219.5	244	14	9	51.5	70	6	M16	36
EQ307R2	VO1A	137.5	24	36	120	186	8	7	27	30	3	M8	19
	VO1B	158	38	58	120	186	10	8	41	50	4	M12	28

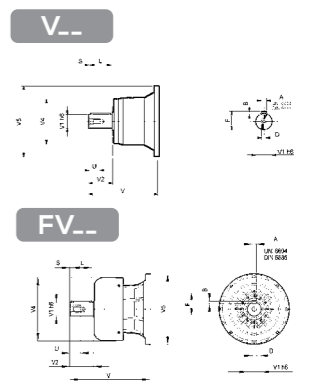

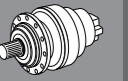
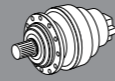

输出轴上的径向载荷位置系数  
RADIAL LOAD POSITION COEFFICIENT ON OUTPUT SHAFT

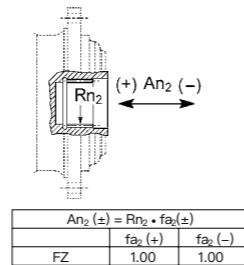
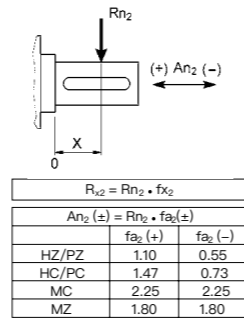
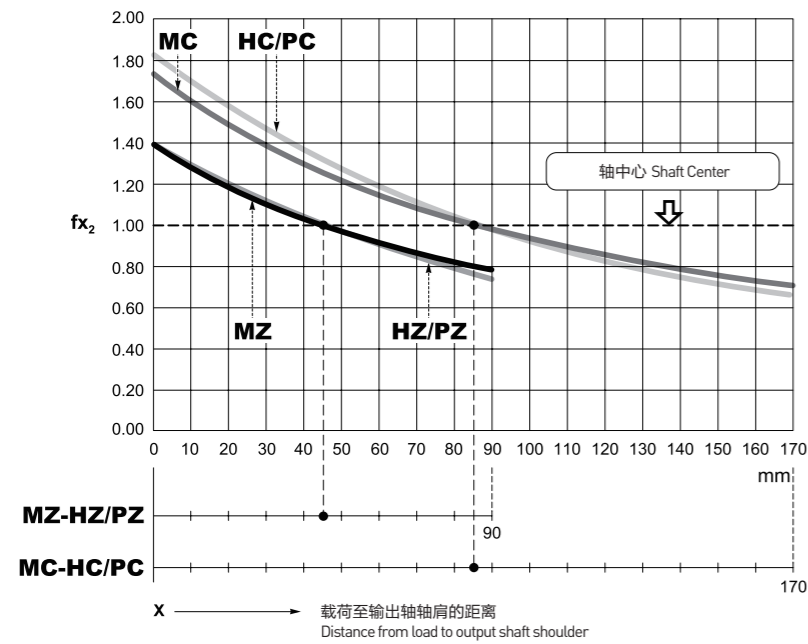

输入转速 $n_1=1000\text{min}^{-1}$ 且假设使用寿命=10000小时, 输入轴上的允许悬臂荷载。  
当输入转速和/或使用寿命不同于这里所列举的值时, 参见样本: 校核。  
Input speed  $n_1=1000\text{min}^{-1}$  and assuming a service life of 10000 hours, the allowable cantilever load on the input shaft.  
When the input speed and/or service life are different from the values listed here, refer to sample: verification.

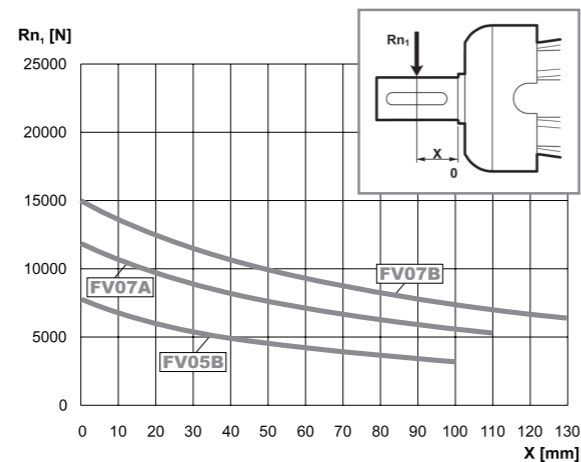
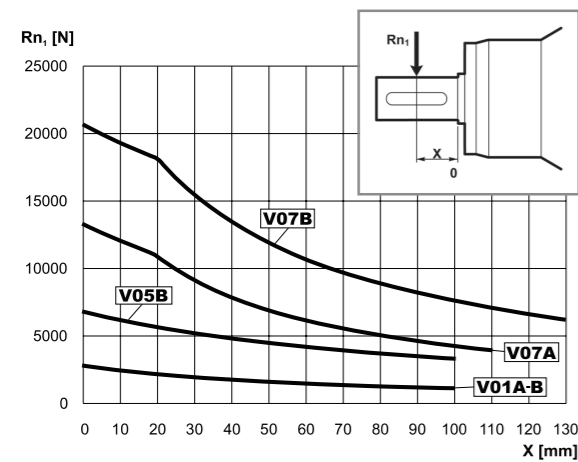

EQ309L

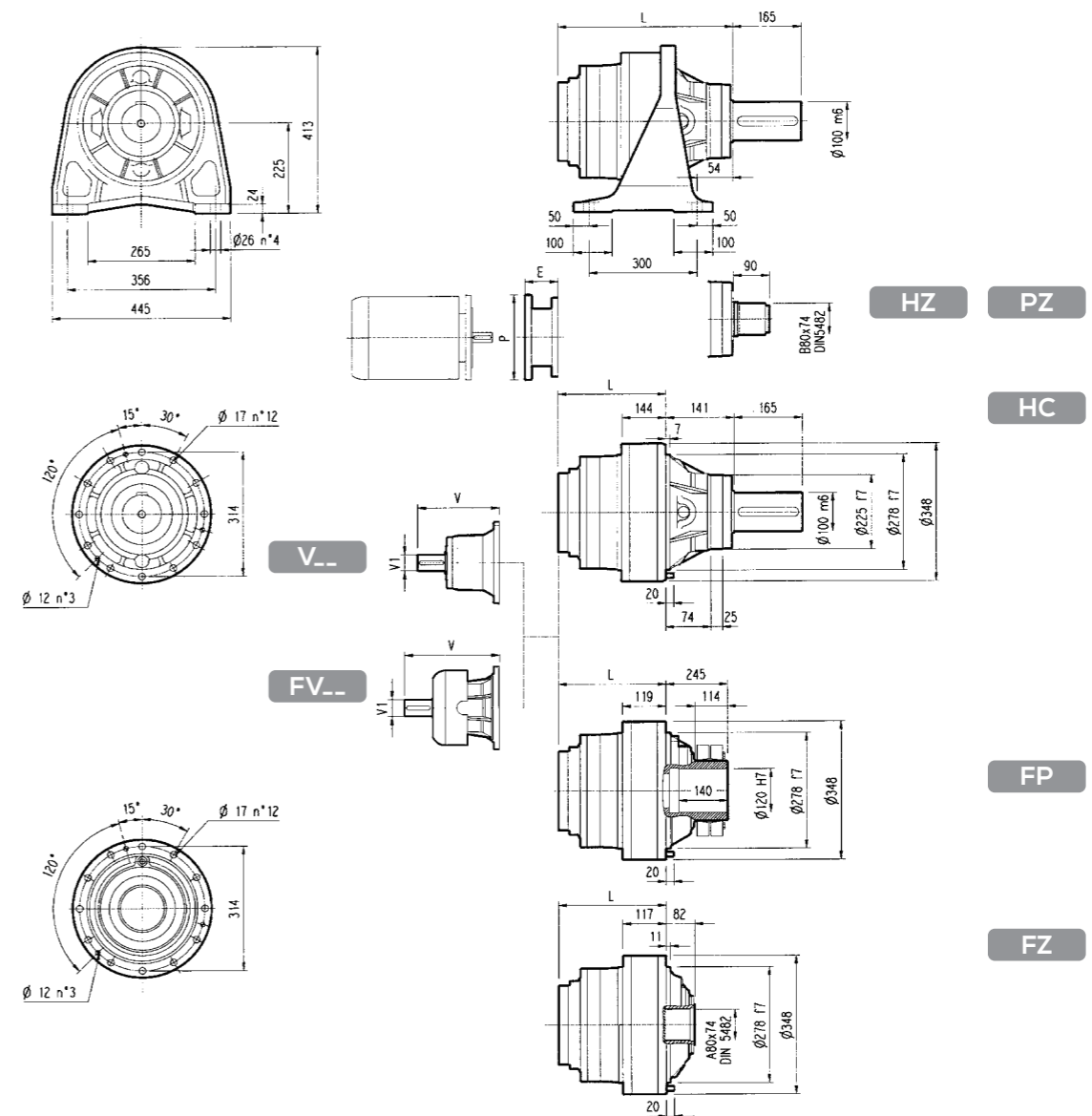

FP  $M_{2max} = 25000 \text{ Nm}$

	L				Kg				输入轴 Input Shaft				输入轴 Input Shaft							
	PC-PZ	HC-HZ	FZ	FP	PC-PZ	HC-HZ	FZ	FP	V	V1	Kg	V	V1	Kg	V	V1	Kg	V	V1	Kg
EQ309L1	267	126	99	101	130	115	95	100	315	80	35	313	60	28	357	80	48	363	60	34
EQ309L2	356	215	188	190	142	127	107	112	239	48	15	-	-	-	276	48	17	-	-	-
EQ309L3	421	280	253	255	149	134	114	119	137.5	24	6	158	38	7	-	-	-	-	-	-
EQ309L4	474	333	306	308	153	138	118	123	137.5	24	6	158	38	7	-	-	-	-	-	-

	P71		P80		P90		P100		P112		P132		P160		P180		P200		P225		P250	
	E	P	E	P	E	P	E	P	E	P	E	P	E	P	E	P	E	P	E	P	E	P
EQ309L1	-	-	-	-	-	-	-	-	-	-	-	-	144	350	195	350	186	400	216	450	216	550
EQ309L2	-	-	-	-	-	-	-	-	-	-	114	300	144	350	144	350	174	400	-	-	-	-
EQ309L3	65	160	84	200	84	200	94	250	94	250	114	300	144	350	-	-	-	-	-	-	-	-
EQ309L4	65	160	84	200	84	200	94	250	94	250	114	300	144	350	-	-	-	-	-	-	-	-

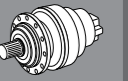
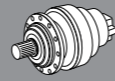

EQ309R

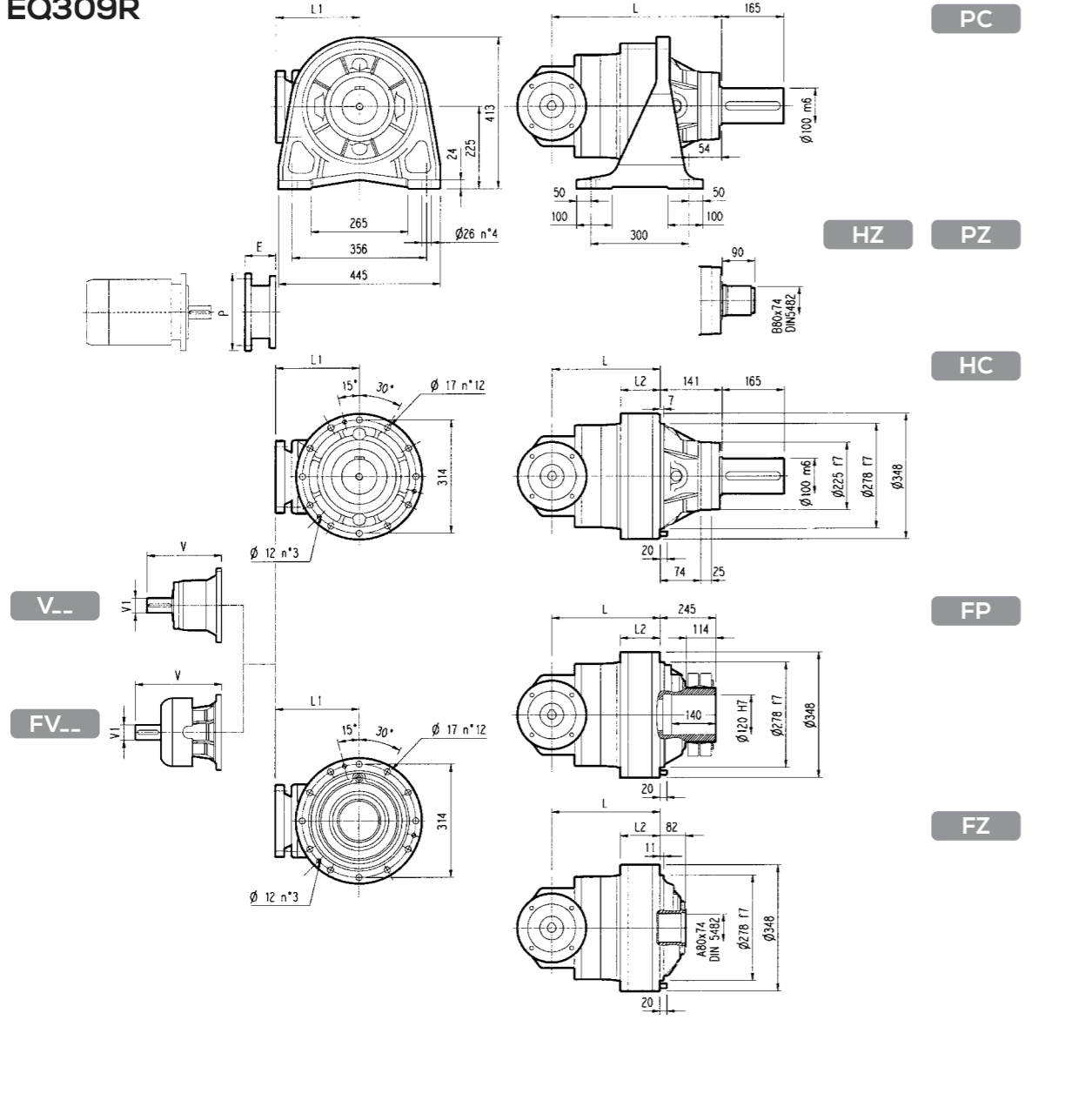

FP  $M_{2max} = 25000 \text{ Nm}$

	L				L1	L2				Kg				输入轴 Input Shaft				输入轴 Input Shaft				
	PC-PZ	HC-HZ	FZ	FP		HC-HZ	FZ	FP	PC-PZ	HC-HZ	FZ	FP	V	V1	Kg	V	V1	Kg	V	V1	Kg	
EQ309R2	386	245	218	220	225	168	141	143	180	165	145	150	239	48	15	-	-	276	48	17	-	-
EQ309R3	448	307	280	282	140	144	117	119	162	147	127	132	137.5	24	6	158	38	7	-	-	-	-
EQ307R4	513	372	345	347	122	144	117	119	163	148	128	133	137.5	24	6	158	38	7	-	-	-	-

	P71		P80		P90		P100		P112		P132		P160		P180		P200	
	E	P	E	P	E	P	E	P	E	P	E	P	E	P	E	P	E	P
EQ309R2	-	-	-	-	-	-	-	-	-	-	114	300	144	350	144	350	174	400
EQ309R3	65	160	84	200	84	200	94	250	94	250	114	300	144	350	-	-	-	-
EQ309R4	65	160	84	200	84	200	94	250	94	250	114	300	144	350	-	-	-	-

EQ309L / ER309R

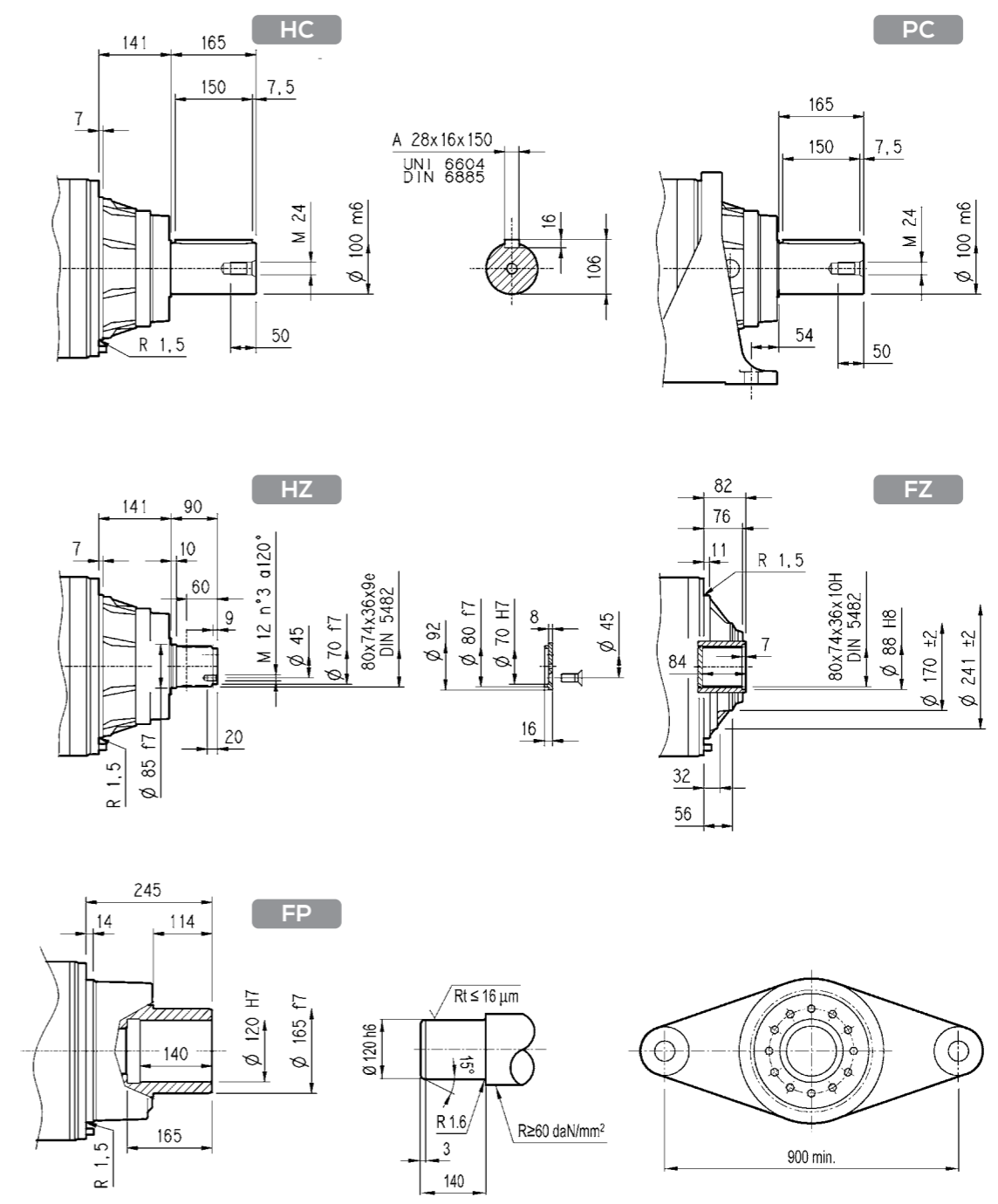

FP  $M_{2max} = 25000 \text{ Nm}$

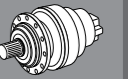
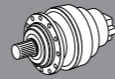

法兰 Flange

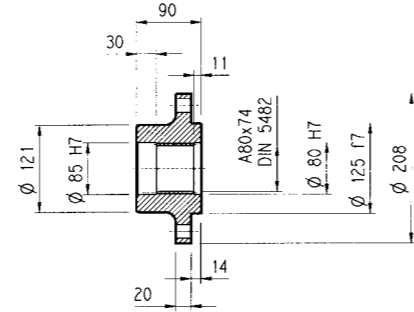
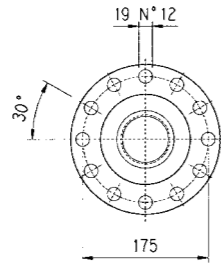
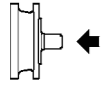

WOA

材料: 45#钢  
Material: 45 # steel

小齿轮 Pinion

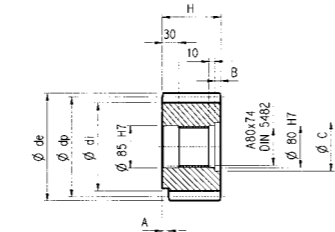

P...

	m	z	x	dp	di	de	H	A	B	C	☆
PFG	8	16	0.500	128	117	149.5	90	0	0	0	□
PHC	10	12	0.450	120	104	145	90	0	0	0	□
PHE	10	14	0.320	140	121	165	116	13	26	95	□
PHF	10	15	0.150	150	130	171.5	107	20	17	100	□
PHG	10	16	0.500	160	145	186	90	0	0	0	■
PHH1	10	17	0	170	145	190	90	0	0	0	■
PHH2	10	17	0.500	170	154	198	90	0	0	0	■
PLD	12	13	0.500	156	138	192	102	0	12	95	□
PLE	12	14	0.500	168	150	199.2	90	0	0	0	□
PLI	12	18	0.500	216	198	249.6	107	7	17	95	□
PLT	12	26	0	312	282	336	90	10	0	0	■

☆ 材料 Material  
□ 42CrMo钢调质 42CrMo steel quenched and tempered  
■ 20CrMnTi钢表面渗碳 Surface carburizing of 20CrMnTi steel

套筒联轴节 Sleeve Coupling

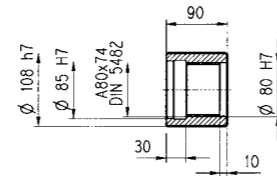

MOA

材料: 42CrMo钢  
Material: 42CrMo steel

花键棒 Spline Bar

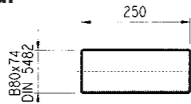
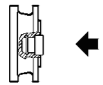

BOA

材料: 42CrMo钢表面硬度HRC45-55  
Material: 42CrMo steel surface hardness HRC45-55

收缩盘 Shrink Disk

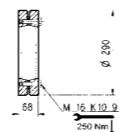
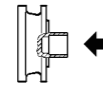

GOA

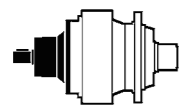

	Input	V	V1	V2	V4	V5	A	B	F	L	S	D	U
EQ309L1	VO7B	315	80	130	200	345	22	14	85	110	10	M16	36
	FV07B	375	80	130	347.5	348	22	14	85	110	10	M16	36
	VO7A	313	60	105	155	345	18	11	64	90	7.5	M16	36
	FV07A	363	60	105	309	348	18	11	64	90	7.5	M16	36
EQ309L2	VO5B	239	48	82	155	245	14	9	51.5	70	6	M16	36
	FV05B	276	48	82	219.5	244	14	9	51.5	70	6	M16	36
EQ309L3	VO1A	137.5	24	36	120	186	8	7	27	30	3	M8	19
	VO1B	158	38	58	120	186	10	8	41	50	4	M12	28
EQ309L4	VO1A	137.5	24	36	120	186	8	7	27	30	3	M8	19
	VO1B	158	38	58	120	186	10	8	41	50	4	M12	28
EQ309R2	VO5B	239	48	82	155	245	14	9	51.5	70	6	M16	36
	FV05B	276	48	82	219.5	244	14	9	51.5	70	6	M16	36
EQ309R3/4	VO1A	137.5	24	36	120	186	8	7	27	30	3	M8	19
	VO1B	158	38	58	120	186	10	8	41	50	4	M12	28

V...

FV...

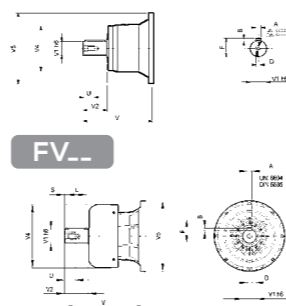

输出轴上的径向载荷位置系数

RADIAL LOAD POSITION COEFFICIENT ON OUTPUT SHAFT

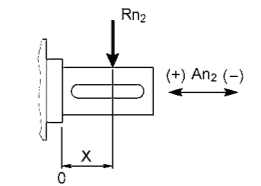
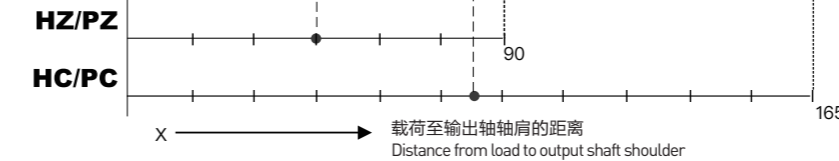
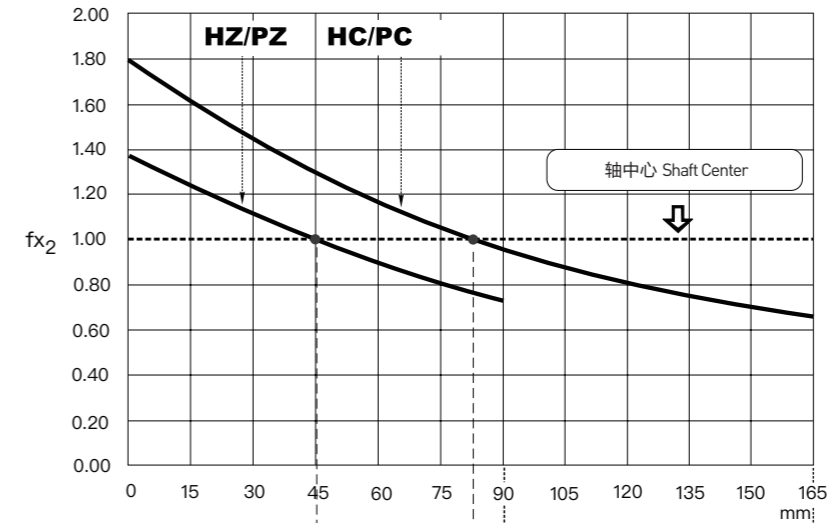

$$R_{x2} = R_{n2} \cdot f_{x2}$$

$$A_{n2}(\pm) = R_{n2} \cdot f_{a2}(\pm)$$

	$f_{a2}(+)$	$f_{a2}(-)$
HZ/PZ	1.10	0.55
HC/PC	1.45	0.73

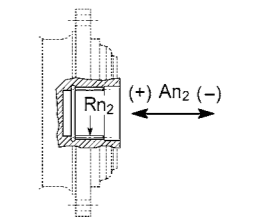

$$A_{n2}(\pm) = R_{n2} \cdot f_{a2}(\pm)$$

	$f_{a2}(+)$	$f_{a2}(-)$
FZ	1.03	1.03

输入转速 $n_1=1000\text{min}^{-1}$ 且假设使用寿命=10000小时, 输入轴上的允许悬臂荷载。

当输入转速和/或使用寿命不同于这里所列举的值时, 参见样本: 校核。

Input speed  $n_1=1000\text{min}^{-1}$  and assuming a service life of 10000 hours, the allowable cantilever load on the input shaft.

When the input speed and/or service life are different from the values listed here, refer to sample: verification.

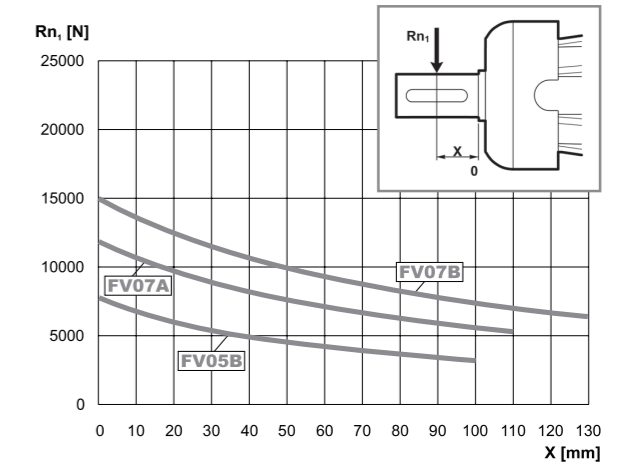
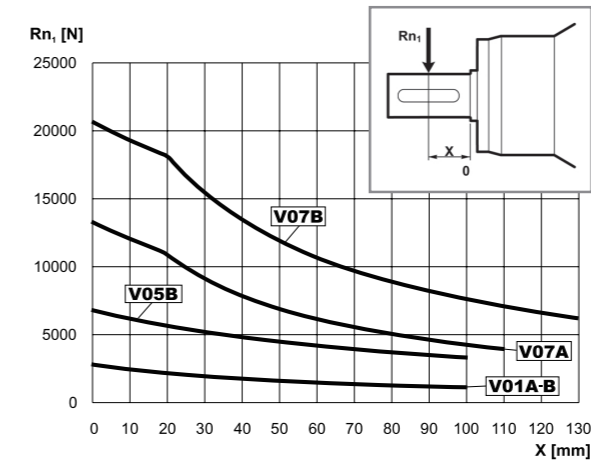

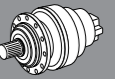
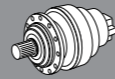

EQ310L

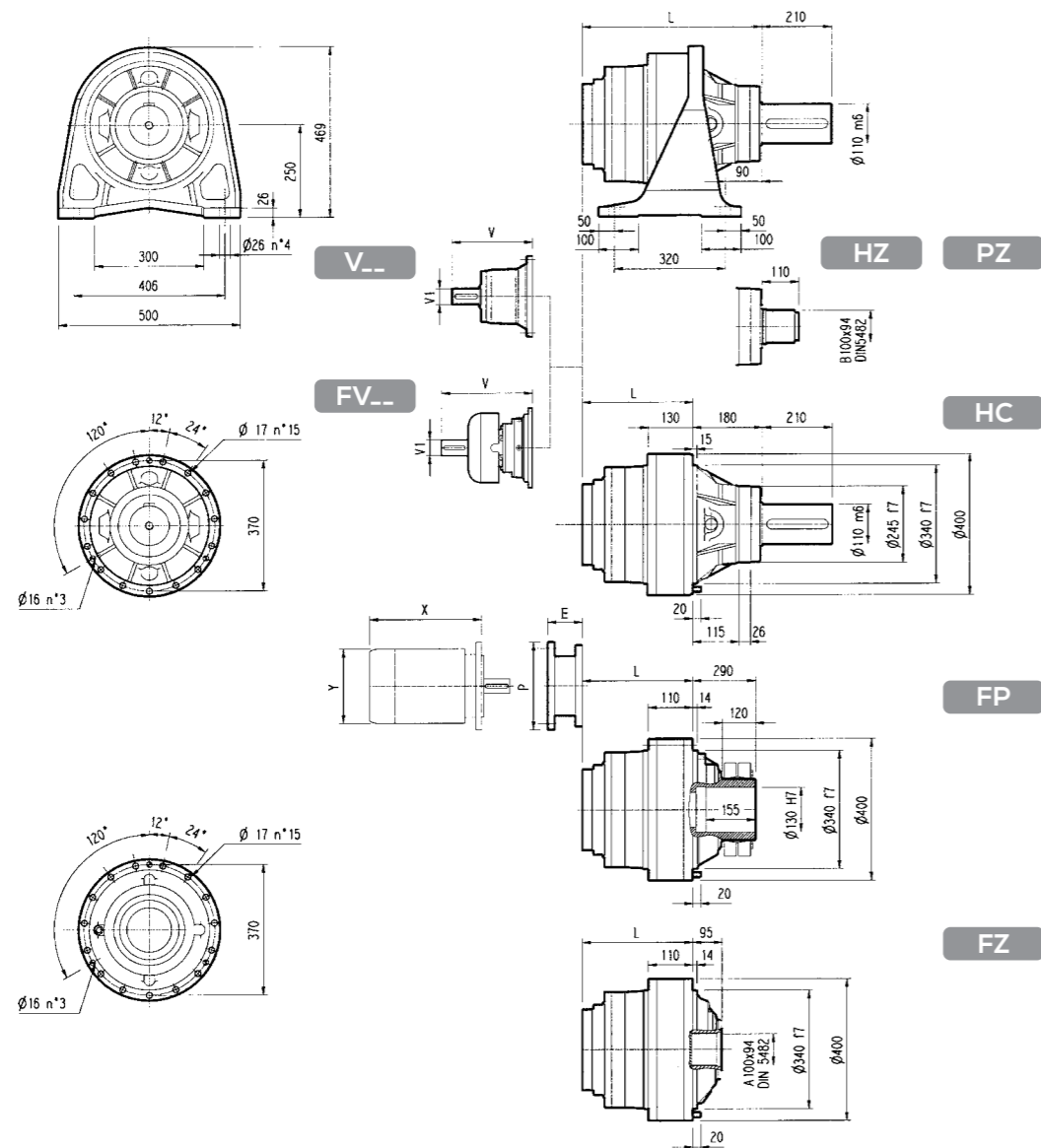

FP  $M_{2max} = 36000 \text{ Nm}$

	L				Kg				输入轴 Input Shaft				输入轴 Input Shaft							
	PC-PZ	HC-HZ	FZ	FP	PC-PZ	HC-HZ	FZ	FP	V	V1	Kg	V	V1	Kg	V	V1	Kg	V	V1	Kg
EQ310L1	288	108	88	88	155	135	110	115	377	80	50	-	-	-	457	80	63	-	-	-
EQ310L2	424	244	224	224	185	165	140	145	307	60	23	-	-	-	357	60	28	-	-	-
EQ310L3	489	309	289	289	194	174	149	154	239	48	15	-	-	-	276	48	17	-	-	-
EQ310L4	542	362	342	342	198	178	153	158	137.5	24	6	158	38	7	-	-	-	-	-	-

	P71		P80		P90		P100		P112		P132		P160		P180		P200		P225		P250	
	E	P	E	P	E	P	E	P	E	P	E	P	E	P	E	P	E	P	E	P	E	P
EQ310L1	-	-	-	-	-	-	-	-	-	-	-	-	-	-	-	-	271	400	301	450	281	550
EQ310L2	-	-	-	-	-	-	-	-	-	-	-	-	152	350	153	350	183	400	212	450	193	550
EQ310L3	-	-	-	-	-	-	-	-	-	-	114	300	144	350	144	350	174	400	-	-	-	-
EQ310L4	65	160	84	200	84	200	94	250	94	250	114	300	144	350	-	-	-	-	-	-	-	-

EQ310R

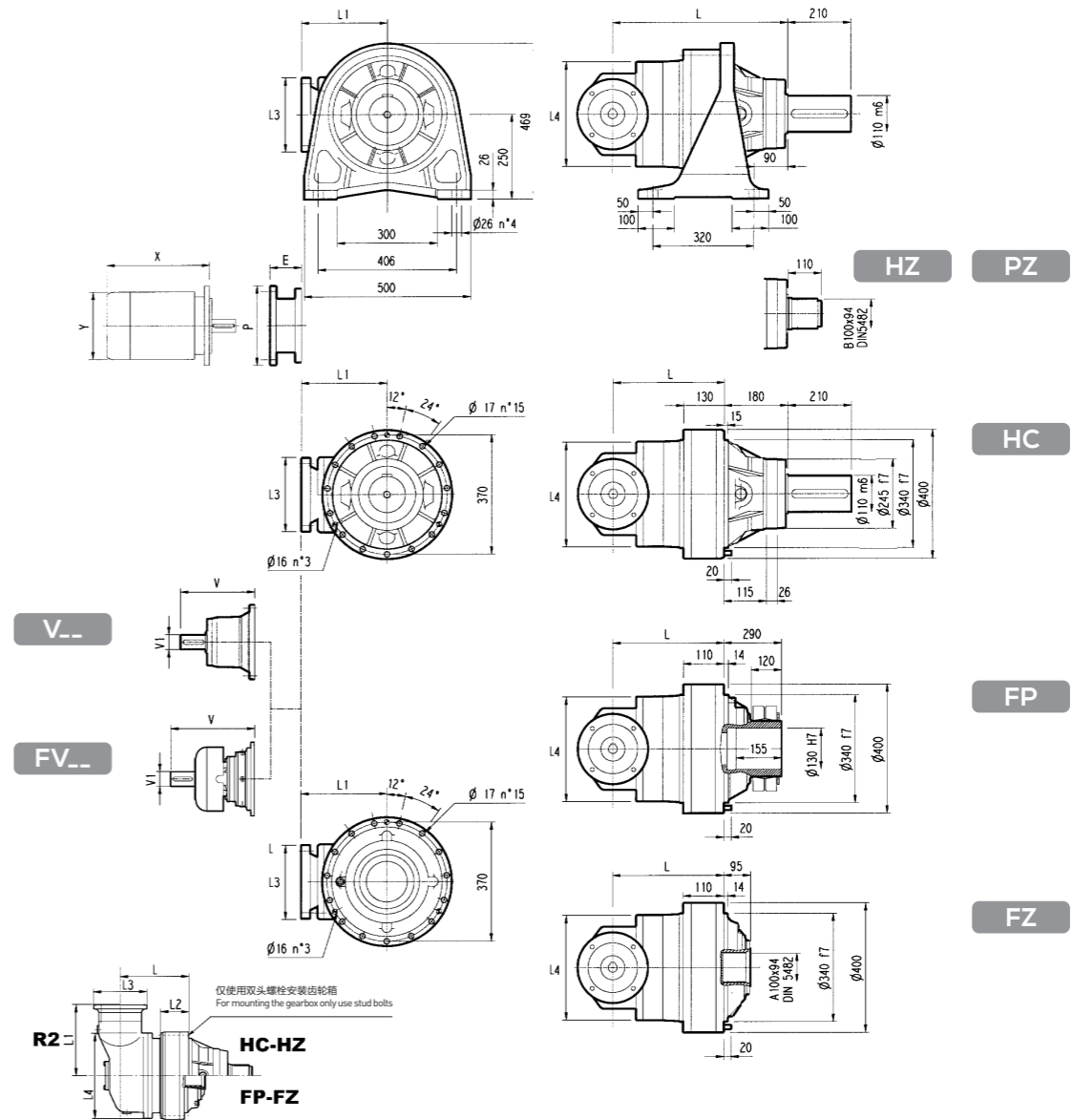

FP  $M_{2max} = 36000 \text{ Nm}$

	L				L1	L3	L4	Kg				输入轴 Input Shaft				输入轴 Input Shaft						
	PC-PZ	HC-HZ	FZ	FP				PC-PZ	HC-HZ	FZ	FP	V	V1	Kg	V	V1	Kg	V	V1	Kg	V	V1
EQ310R2(B)	485	305	285	285	345	292	400	280	260	240	250	307	60	23	-	-	-	357	60	28	-	-
EQ310R2(C)	513	333	313	313	390	292	480	300	280	260	270	307	60	23	-	-	-	357	60	28	-	-
EQ310R3	561	381	361	361	140	186	244	209	189	164	169	137.5	24	6	158	38	7	-	-	-	-	-
EQ310R4	581	401	381	381	140	186	244	214	194	169	174	137.5	24	6	158	38	7	-	-	-	-	-

	P71		P80		P90		P100		P112		P132		P160		P180		P200		P225			
	E	P	E	P	E	P	E	P	E	P	E	P	E	P	E	P	E	P	E	P		
EQ310R2(B)	-	-	-	-	-	-	-	-	-	-	-	-	-	-	152	350	182	400	212	450		
EQ310R2(C)	-	-	-	-	-	-	-	-	-	-	-	-	114	300	152	350	152	350	182	400	212	450
EQ310R3	65	160	84	200	84	200	94	250	94	250	114	300	144	350	-	-	-	-	-	-	-	
EQ310R4	65	160	84	200	84	200	94	250	94	250	114	300	144	350	-	-	-	-	-	-	-	

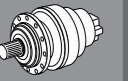
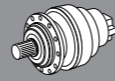

EQ310L / ER310R

HC

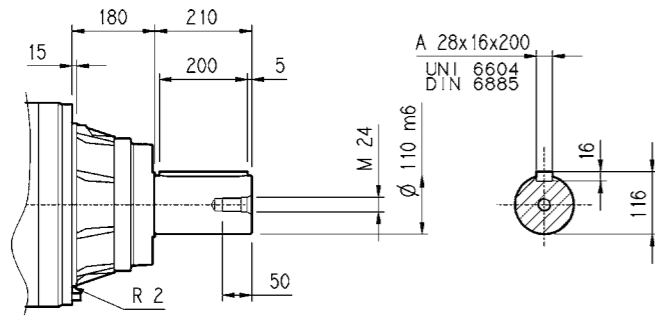

PC

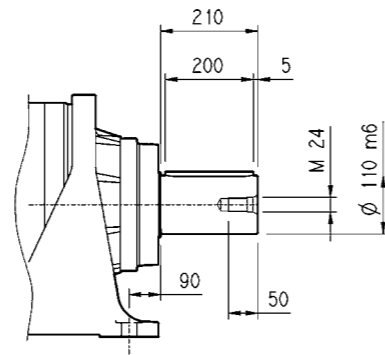

HZ

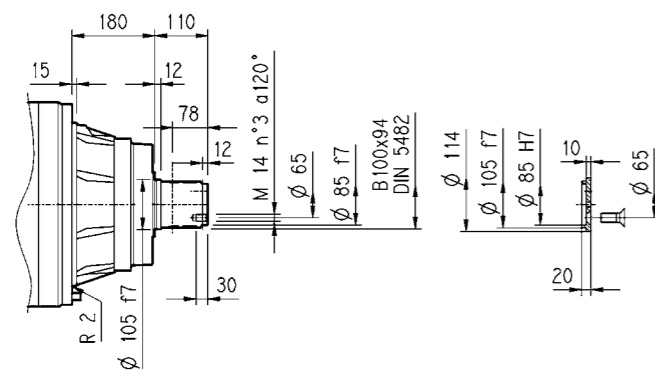

FZ

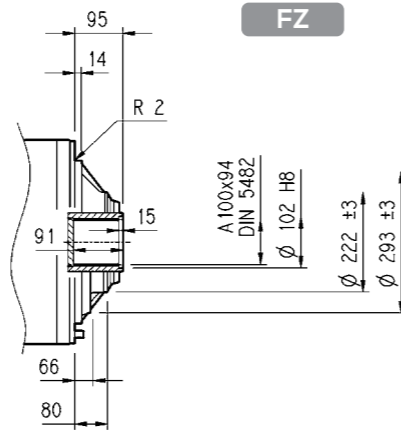

FP

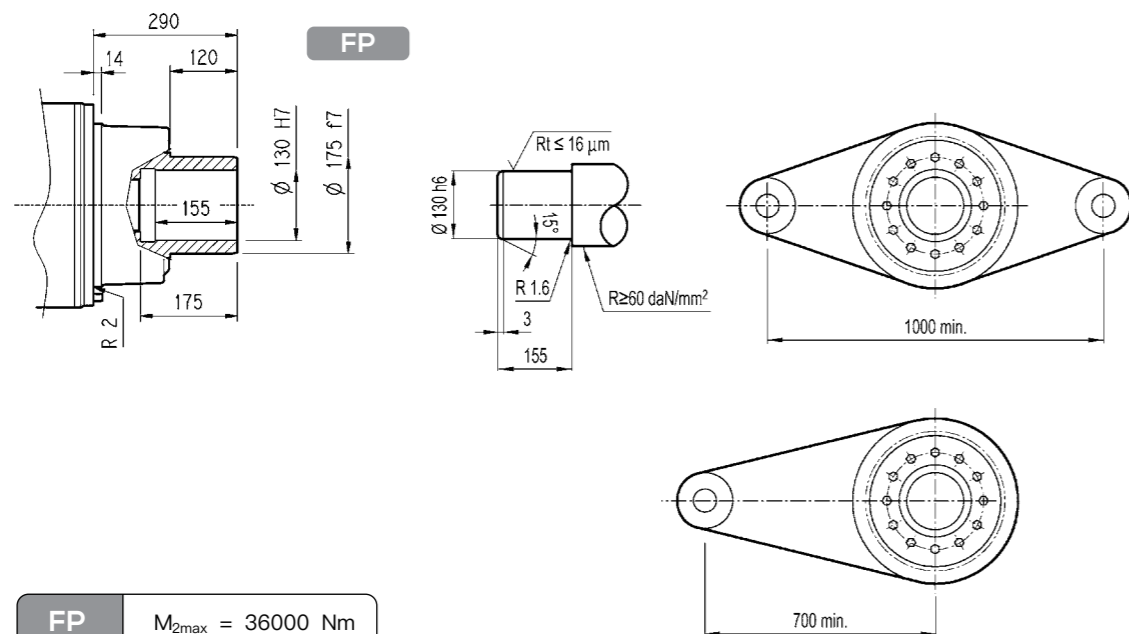

FP  $M_{2max} = 36000\text{ Nm}$

法兰 Flange

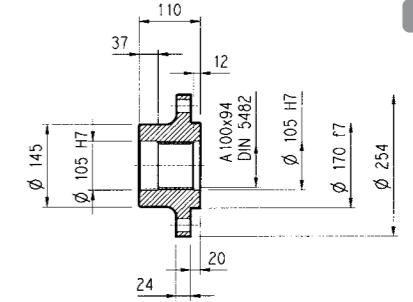
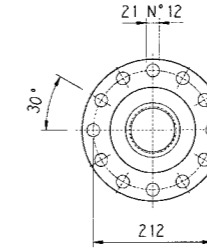
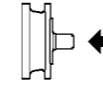

WOA

材料: 45#钢  
Material: 45 # steel

小齿轮 Pinion

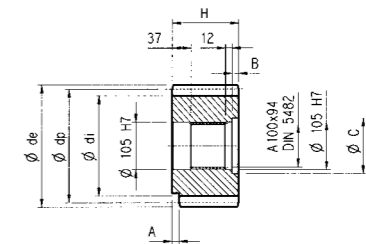

P...

	m	z	x	dp	di	de	H	A	B	C	☆
PLQ	12	23	0	276	246	300	110	0	0	0	■
PLD	16	13	0.500	208	184	252.5	145	0	35	116	□
PPF	16	15	0.450	240	215	280	125	0	15	120	□

☆ 材料 Material  
 □ 42CrMo钢调质 42CrMo steel quenched and tempered  
 ■ 20CrMnTi钢表面渗碳 Surface carburizing of 20CrMnTi steel

套筒联轴节 Sleeve Coupling



材料: 42CrMo钢  
Material: 42CrMo steel

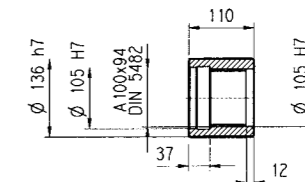

MOA

花键棒 Spline Bar

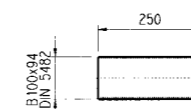
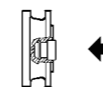

BOA

材料: 42CrMo钢表面硬度HRC45-55  
Material: 42CrMo steel surface hardness HRC45-55

收缩盘 Shrink Disk

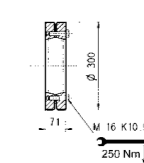
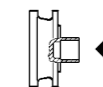

GOA

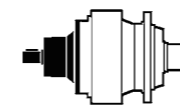

	Input	V	V1	V2	V4	V5	A	B	F	L	S	D	U
EQ310L1	V10B	377	80	130	200	400	22	14	85	110	10	M16	36
	FV10B	457	80	130	347.5	400	22	14	85	110	10	M16	36
EQ310L2	VO6B	307	60	105	155	292	18	11	64	90	7.5	M16	36
	FV06B	357	60	105	309	292	18	11	64	90	7.5	M16	36
EQ310L3	VO5B	239	48	82	155	245	14	9	51.5	70	6	M16	36
	FV05B	276	48	82	219.5	244	14	9	51.5	70	6	M16	36
EQ310L4	VO1A	137.5	24	36	120	186	8	7	27	30	3	M8	19
	VO1B	158	38	58	120	186	10	8	41	50	4	M12	28
EQ310R2(B)(B)	VO6B	307	60	105	155	292	18	11	64	90	7.5	M16	36
	FV06B	357	60	105	309	292	18	11	64	90	7.5	M16	36
EQ310R3/4	VO1A	137.5	24	36	120	186	8	7	27	30	3	M8	19
	VO1B	158	38	58	120	186	10	8	41	50	4	M12	28

V..

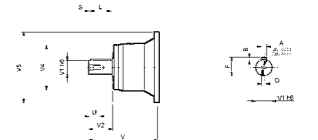

FV..

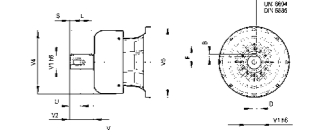

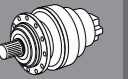
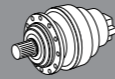

输出轴上的径向载荷位置系数  
RADIAL LOAD POSITION COEFFICIENT ON OUTPUT SHAFT

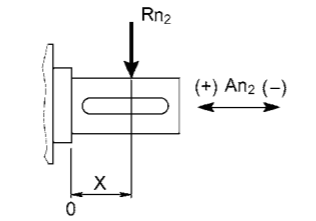
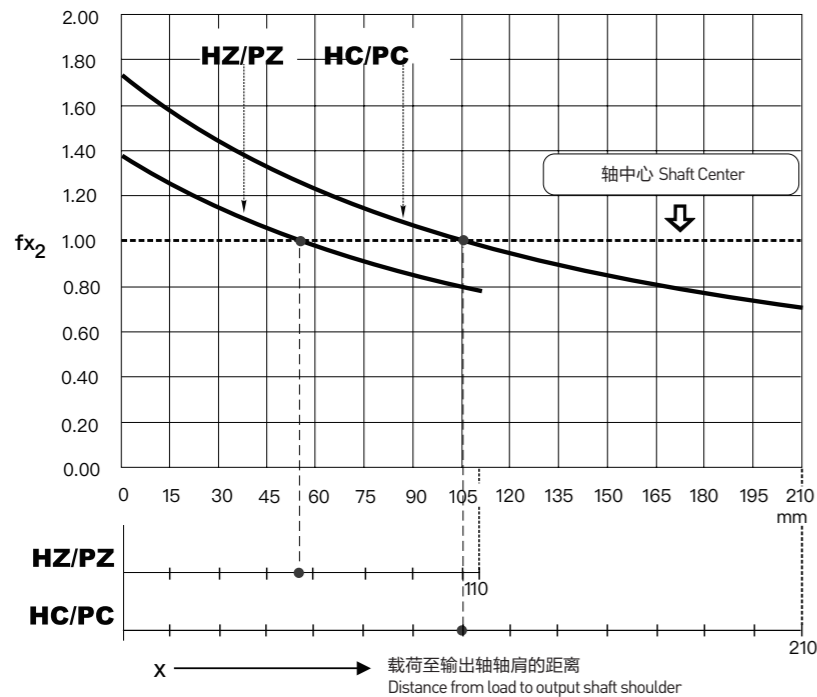

$$R_{x2} = Rn_2 \cdot fx_2$$

$$An_2 (\pm) = Rn_2 \cdot fa_2 (\pm)$$

	$fa_2 (+)$	$fa_2 (-)$
HZ/PZ	1.02	0.60
HC/PC	1.28	0.75

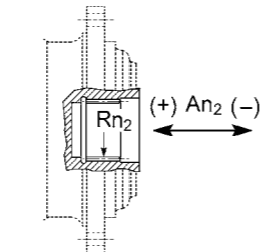

$$An_2 (\pm) = Rn_2 \cdot fa_2 (\pm)$$

	$fa_2 (+)$	$fa_2 (-)$
FZ	0.80	0.80

输入转速 $n_1=1000\text{min}^{-1}$ 且假设使用寿命=10000小时, 输入轴上的允许悬臂荷载。  
当输入转速和/或使用寿命不同于这里所列举的值时, 参见样本: 校核。

Input speed  $n_1=1000\text{min}^{-1}$  and assuming a service life of 10000 hours, the allowable cantilever load on the input shaft.  
When the input speed and/or service life are different from the values listed here, refer to sample: verification.

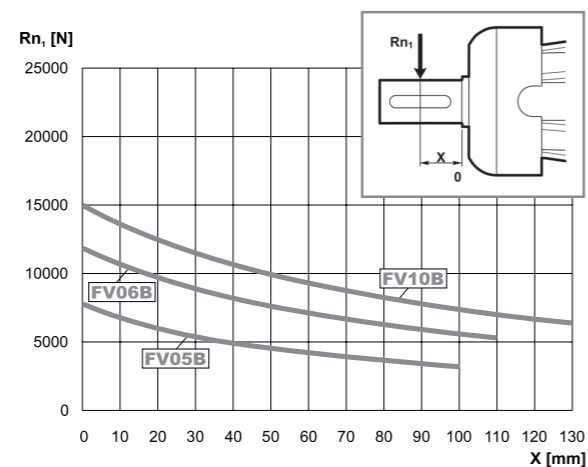
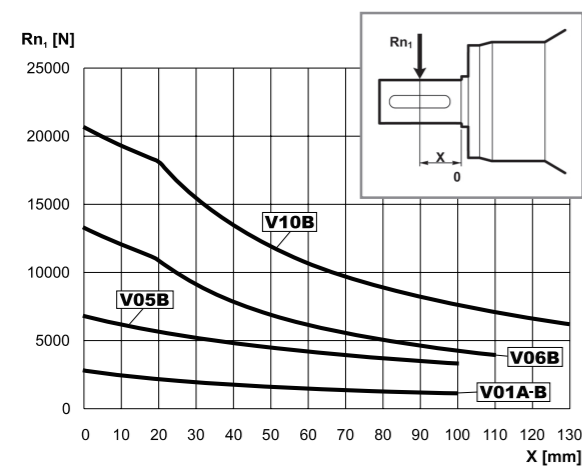

EQ311L

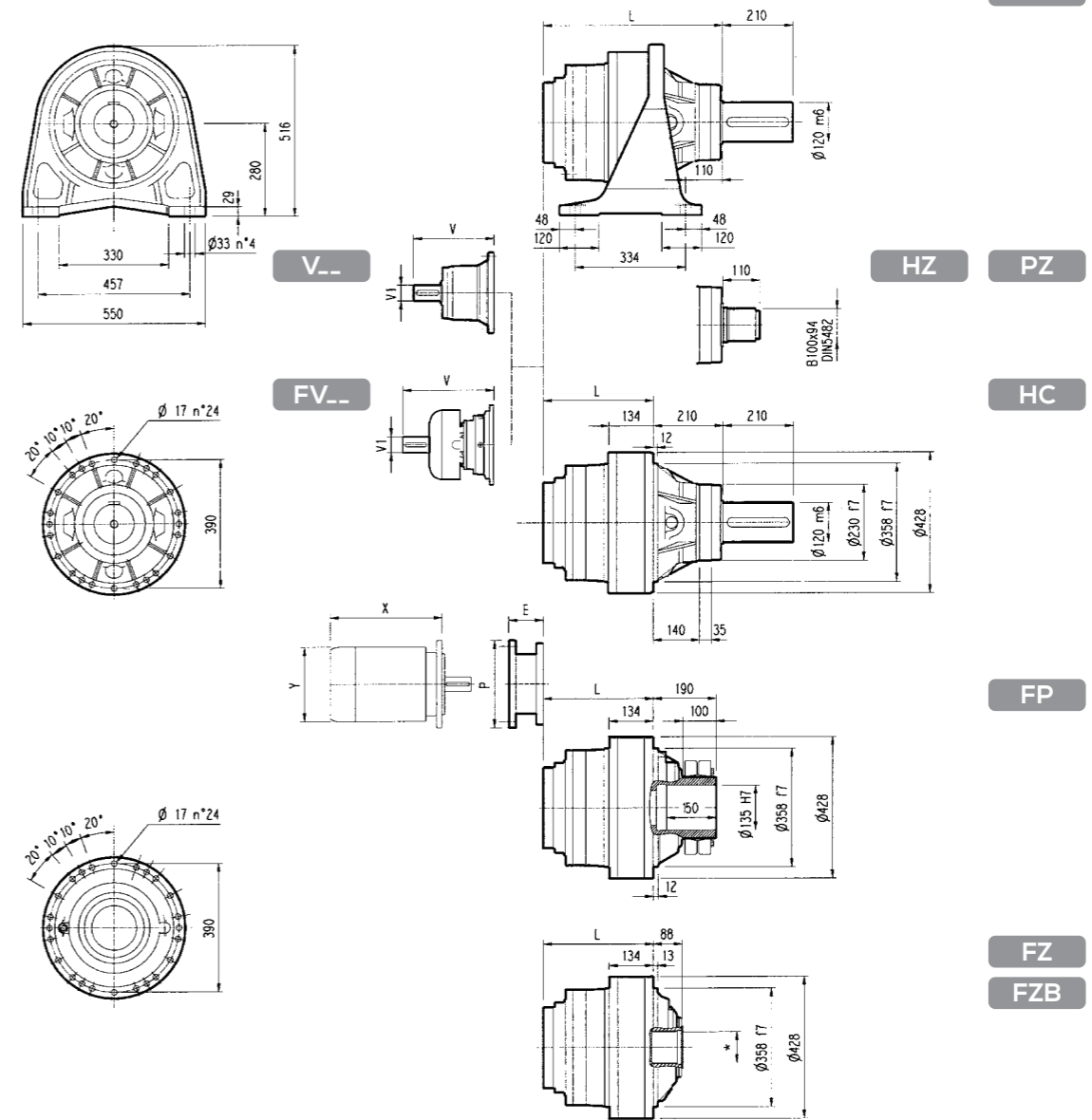

FP  $M_{2max} = 54000 \text{ Nm}$

	L				Kg				输入轴 Input Shaft				输入轴 Input Shaft							
	PC-PZ	HC-HZ	FZ	FP	PC-PZ	HC-HZ	FZ	FP	V	V1	Kg	V	V1	Kg	V	V1	Kg			
EQ311L1	325	115	115	115	250	180	160	170	348	80	55	-	-	-	456	80	85	-	-	
EQ311L2	458	248	248	248	295	225	205	215	315	80	35	313	60	28	357	80	48	363	60	34
EQ311L3	547	337	337	337	307	237	217	227	239	48	15	-	-	-	276	48	17	-	-	-
EQ311L4	612	402	402	402	314	244	224	234	137.5	24	6	158	38	7	-	-	-	-	-	-

	P71		P80		P90		P100		P112		P132		P160		P180		P200		P225		P250	
	E	P	E	P	E	P	E	P	E	P	E	P	E	P	E	P	E	P	E	P	E	P
EQ311L2	-	-	-	-	-	-	-	-	-	-	-	-	144	350	195	350	186	400	216	450	216	550
EQ311L3	-	-	-	-	-	-	-	-	-	-	114	300	144	350	144	350	174	400	-	-	-	-
EQ311L4	65	160	84	200	84	200	94	250	94	250	114	300	144	350	-	-	-	-	-	-	-	-

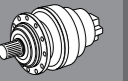
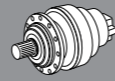

EQ311R

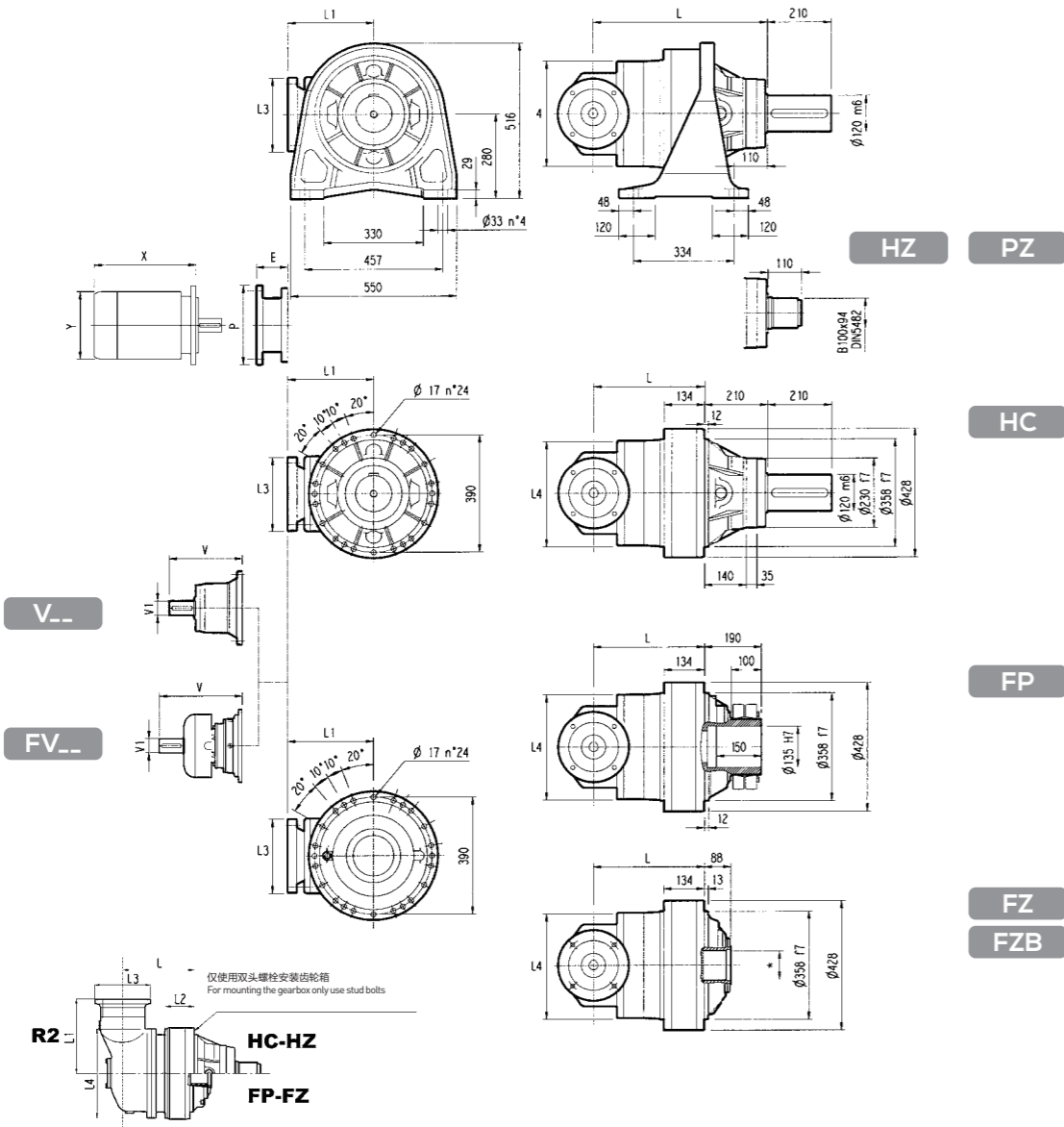

FP  $M_{2max} = 54000 \text{ Nm}$

	L				L1	L3	L4	输入轴 Input Shaft				输入轴 Input Shaft									
	PC-PZ		HC-HZ					FZ		FP		V	V1	Kg	V	V1	Kg				
	E	P	E	P				E	P	E	P										
EQ311R2(B)	550	340	340	340	345	292	400	380	310	290	300	307	60	23	-	-	357	60	28	-	-
EQ311R2(C)	550	340	340	340	390	292	480	390	320	300	310	307	60	23	-	-	357	60	28	-	-
EQ311R3	577	367	367	367	225	245	375	345	275	255	265	239	48	15	-	-	276	48	17	-	-
EQ311R4	639	429	429	429	140	186	244	327	257	237	247	137.5	24	6	158	38	7	-	-	-	-

	P71		P80		P90		P100		P112		P132		P160		P180		P200		P225		P250	
	E	P	E	P	E	P	E	P	E	P	E	P	E	P	E	P	E	P	E	P	E	P
EQ311R2(B)	-	-	-	-	-	-	-	-	-	-	-	-	-	-	152	350	182	400	212	450	193	550
EQ311R2(C)	-	-	-	-	-	-	-	-	-	-	-	-	-	-	152	350	182	400	212	450	193	550
EQ311R3	-	-	-	-	-	-	-	-	-	-	114	300	144	350	144	350	174	400	-	-	-	-
EQ311R4	65	160	84	200	84	200	94	250	94	250	114	300	144	350	-	-	-	-	-	-	-	

EQ311L / ER311R

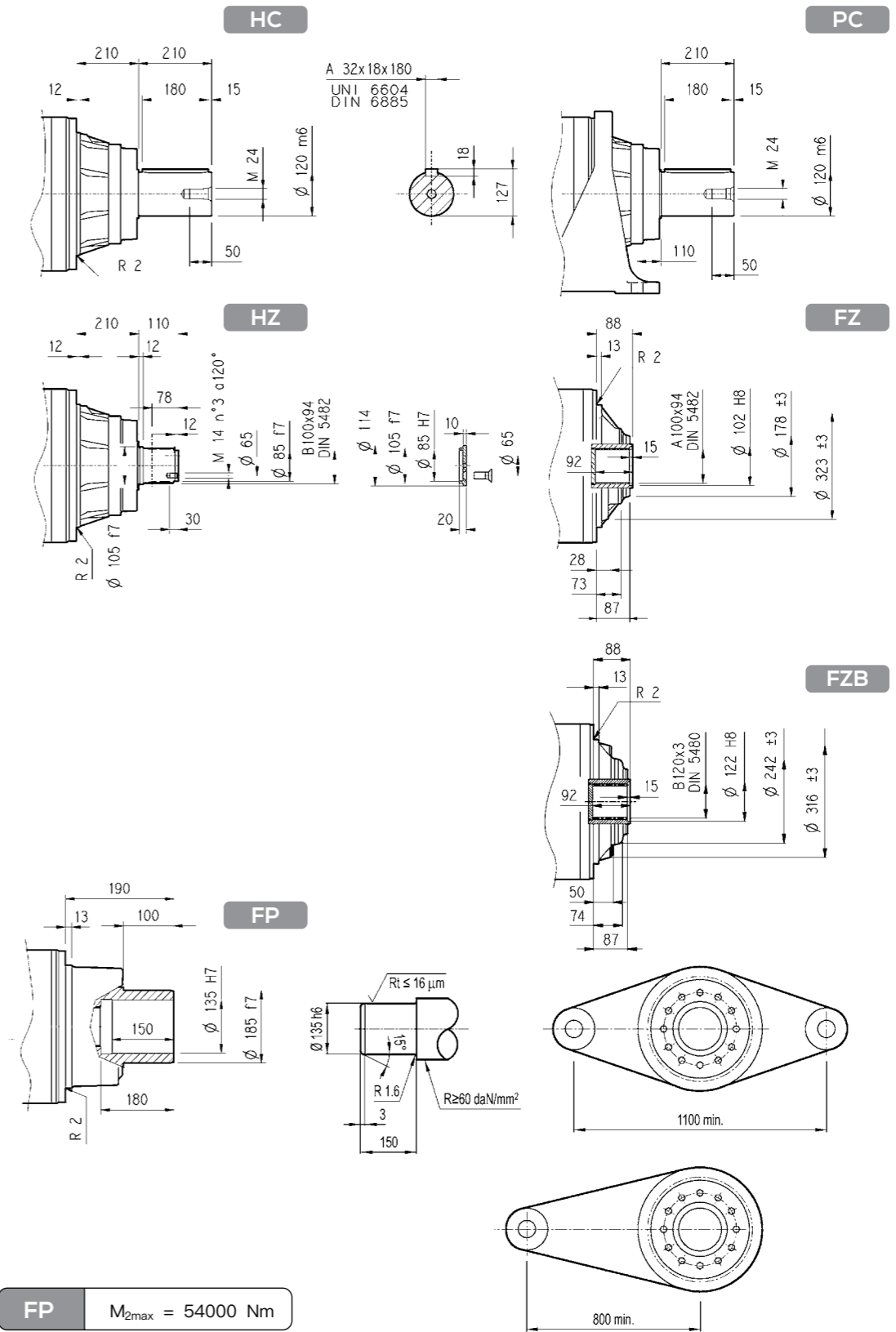

FP  $M_{2max} = 54000 \text{ Nm}$

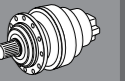
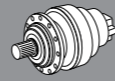

EQ313L

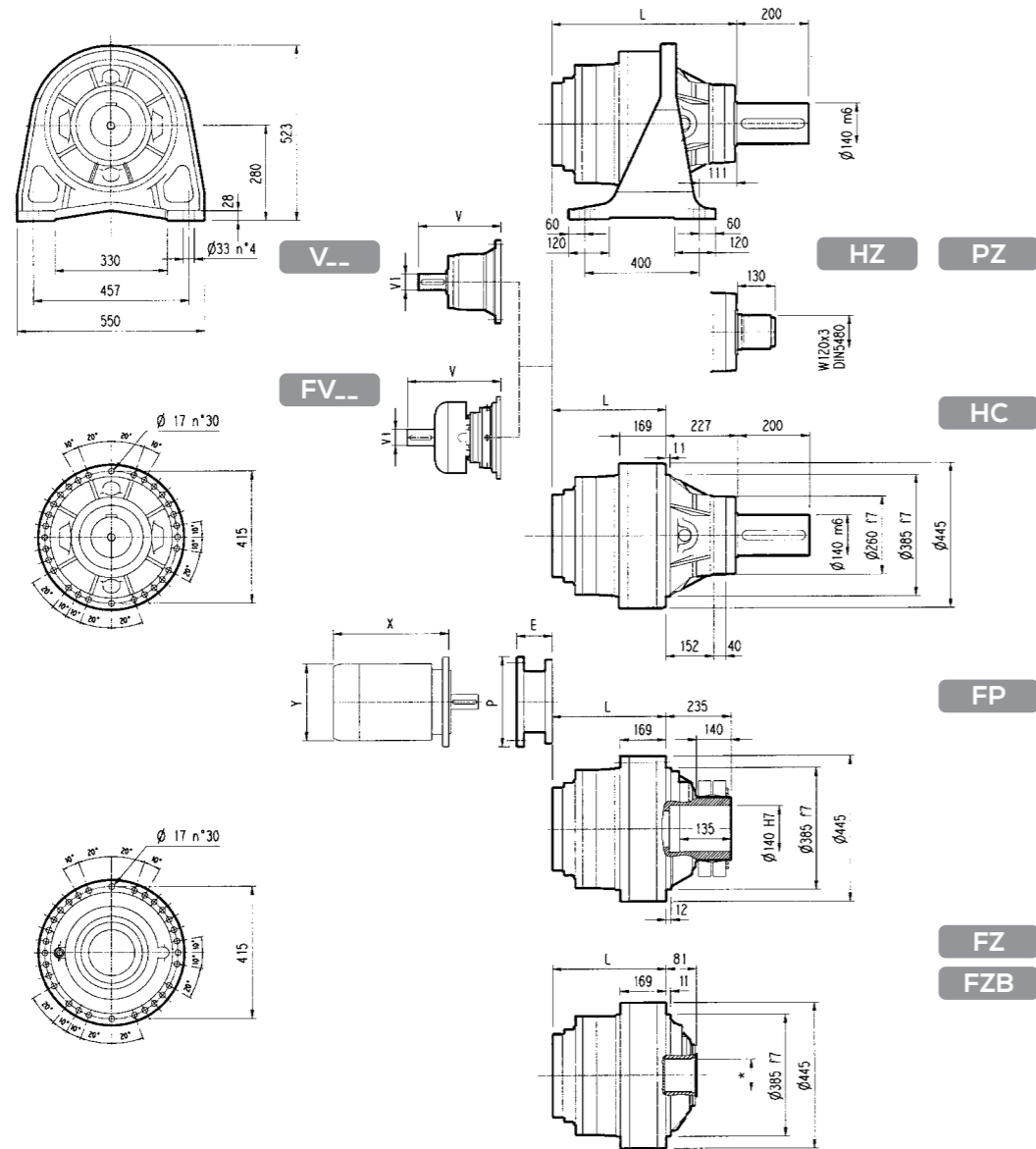

FP  $M_{2max} = 66000 \text{ Nm}$

	L				Kg				输入轴 Input Shaft				输入轴 Input Shaft							
	PC-PZ	HC-HZ	FZ	FP	PC-PZ	HC-HZ	FZ	FP	V	V1	Kg	V	V1	Kg	V	V1	Kg	V	V1	Kg
EQ313L1	381	154	154	154	320	230	200	200	343	80	55	-	-	-	451	80	71	-	-	-
EQ313L2	531	304	304	304	380	290	260	280	315	80	35	313	60	28	375	80	48	363	60	34
EQ313L3	620	393	393	393	392	302	272	292	239	48	15	-	-	-	276	48	17	-	-	-
EQ313L4	685	458	458	458	399	309	279	299	137.5	24	6	158	38	7	-	-	-	-	-	-

	P71		P80		P90		P100		P112		P132		P160		P180		P200		P225		P250	
	E	P	E	P	E	P	E	P	E	P	E	P	E	P	E	P	E	P	E	P	E	P
EQ313L2	-	-	-	-	-	-	-	-	-	-	-	-	-	-	195	350	186	400	216	450	216	550
EQ313L3	-	-	-	-	-	-	-	-	-	-	114	300	144	350	144	350	174	400	-	-	-	-
EQ313L4	65	160	84	200	84	200	94	250	94	250	114	300	144	350	-	-	-	-	-	-	-	-

EQ313R

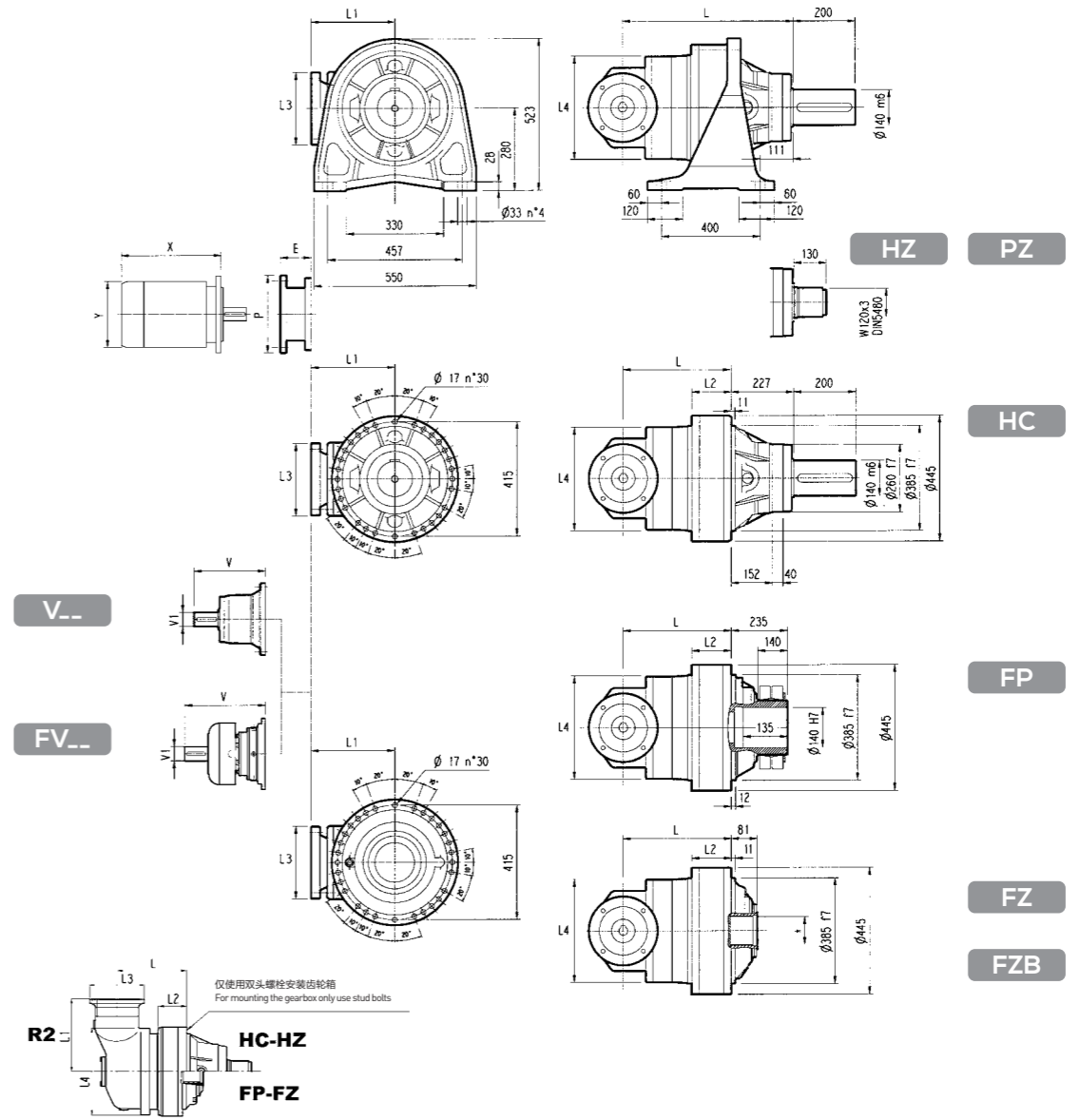

FP  $M_{2max} = 66000 \text{ Nm}$

	L				L1	L2			L3	L4	Kg				输入轴 Input Shaft				输入轴 Input Shaft						
	PC-PZ	HC-HZ	FZ	FP		HC-HZ	FZ	FP			PC-PZ	HC-HZ	FZ	FP	V	V1	Kg	V	V1	Kg	V	V1	Kg	V	V1
EQ313R2(B)	611	384	384	384	345	199	199	199	292	400	450	360	330	350	307	60	23	-	-	-	357	60	28	-	-
EQ313R2(C)	611	384	384	384	390	168	168	168	292	480	460	370	340	360	307	60	23	-	-	-	357	60	28	-	-
EQ313R3	650	423	423	423	225	169	169	169	245	345	430	340	310	330	239	48	15	-	-	-	-	-	-	-	-
EQ313R4	712	485	485	485	140	169	169	169	186	244	412	322	292	312	137.5	24	6	158	38	7	-	-	-	-	-

	P71		P80		P90		P100		P112		P132		P160		P180		P200		P225		P250		
	E	P	E	P	E	P	E	P	E	P	E	P	E	P	E	P	E	P	E	P	E	P	
EQ313R2(B)	-	-	-	-	-	-	-	-	-	-	-	-	-	-	152	350	182	400	212	450	193	550	
EQ313R2(C)	-	-	-	-	-	-	-	-	-	-	-	-	-	-	152	350	182	400	212	450	193	550	
EQ313R3	-	-	-	-	-	-	-	-	-	-	-	-	-	114	300	144	350	144	350	174	400	-	-
EQ313R4	65	160	84	200	84	200	94	250	94	250	114	300	144	350	-	-	-	-	-	-	-	-	

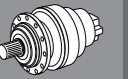
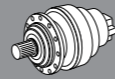

EQ313L / ER313R

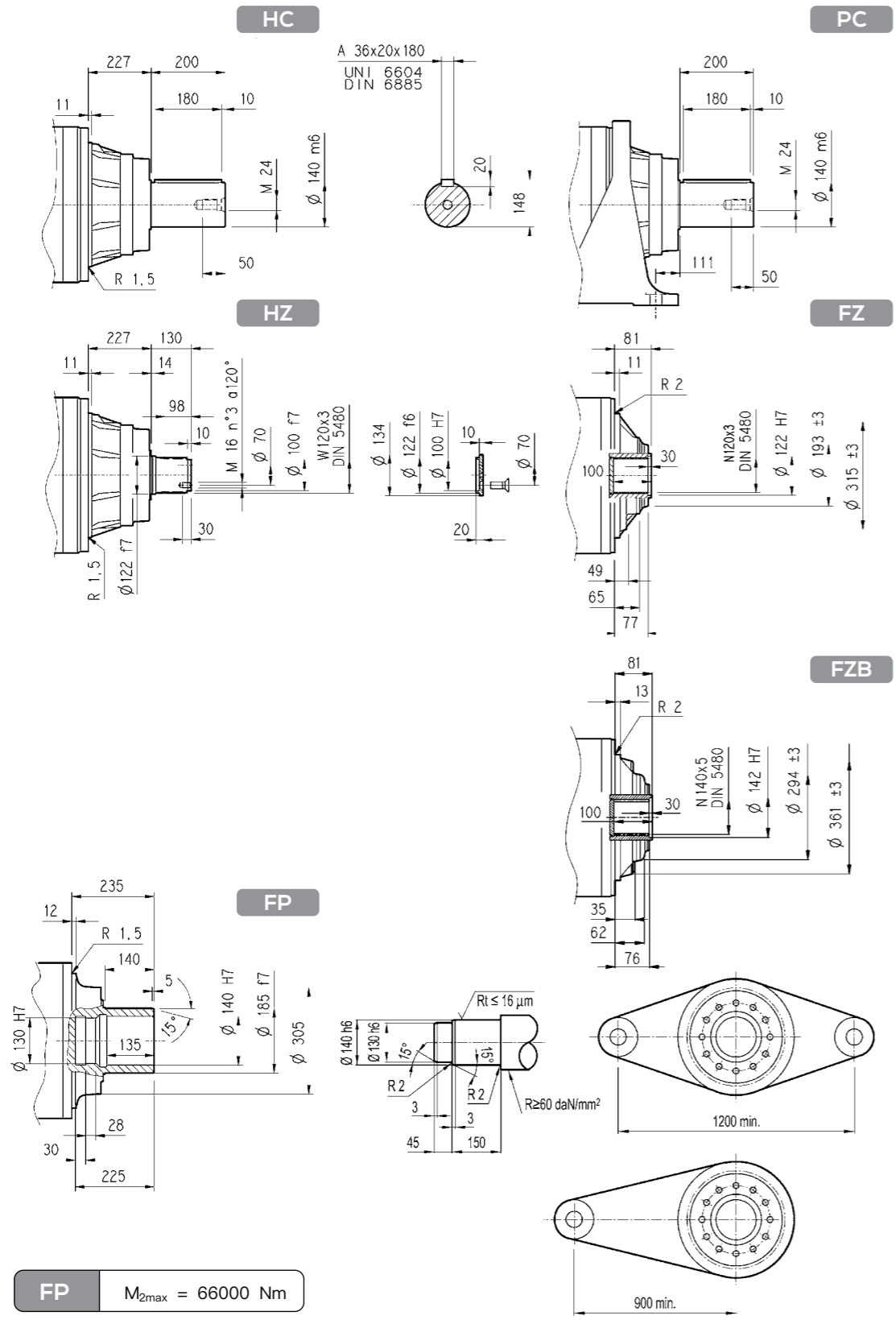

FP M<sub>2max</sub> = 66000 Nm

法兰 Flange

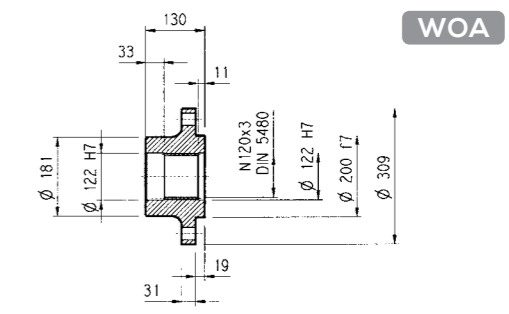
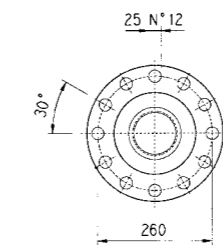
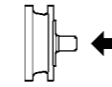

材料: 45#钢  
Material: 45 # steel

小齿轮 Pinion

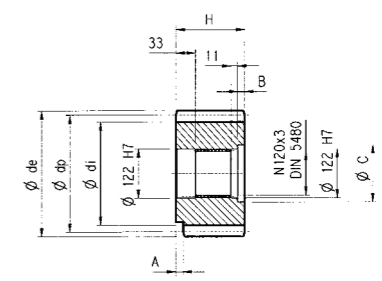

	m	z	x	dp	di	de	H	A	B	C	☆
PPH	16	17	0.500	272	247	315	135	0	5	136	□
PRI	18	18	0.333	324	294	365	140	0	10	140	□

☆ 材料 Material  
□ 42CrMo钢调质 42CrMo steel quenched and tempered  
■ 20CrMnTi钢表面渗碳 Surface carburizing of 20CrMnTi steel

套筒联轴节 Sleeve Coupling

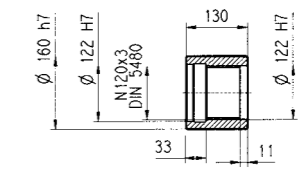
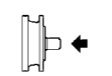

材料: 42CrMo钢  
Material: 42CrMo steel

花键棒 Spline Bar

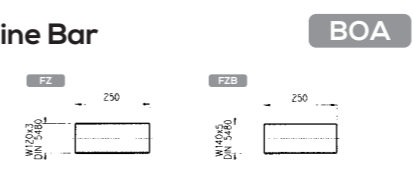
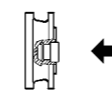

材料: 42CrMo钢表面硬度HRC45-55  
Material: 42CrMo steel surface hardness HRC45-55

收缩盘 Shrink Disk

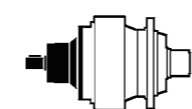
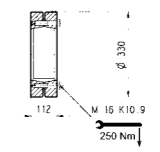
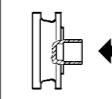

	Input	V	V1	V2	V4	V5	A	B	F	L	S	D	U
EQ313L1	V11B	343	80	130	200	445	22	14	85	110	10	M16	36
	FV11B	451	80	130	347.5	445	22	14	85	110	10	M16	36
	V07B	315	80	130	200	345	22	14	85	110	10	M16	36
EQ313L2	FV07B	375	80	130	347.5	348	22	14	85	110	10	M16	36
	V07A	313	60	105	155	345	18	11	12	90	7.5	M16	36
	FV07A	363	60	105	309	348	18	11	64	90	7.5	M16	36
EQ313L3	V05B	239	48	82	155	245	14	9	51.5	70	6	M16	36
	FV05B	276	48	82	219.5	244	14	9	51.5	70	6	M16	36
EQ313L4	V01A	137.5	24	36	120	186	8	7	27	30	3	M8	19
	V01B	158	38	58	120	186	10	8	41	50	4	M12	28
EQ313R2(B)(C)	V06B	307	60	105	155	292	18	11	64	90	7.5	M16	36
	FV06B	357	60	105	309	292	18	11	64	90	7.5	M16	36
EQ313R3	V05B	239	48	82	155	245	14	9	51.5	70	6	M16	36
	V01A	137.5	24	36	120	186	8	7	27	30	3	M8	19
EQ313R4	V01B	158	38	58	120	186	10	8	41	50	4	M12	28

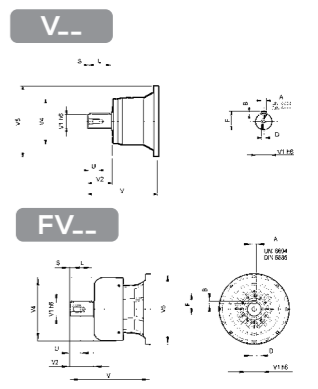

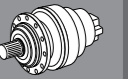
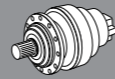

输出轴上的径向载荷位置系数  
RADIAL LOAD POSITION COEFFICIENT ON OUTPUT SHAFT

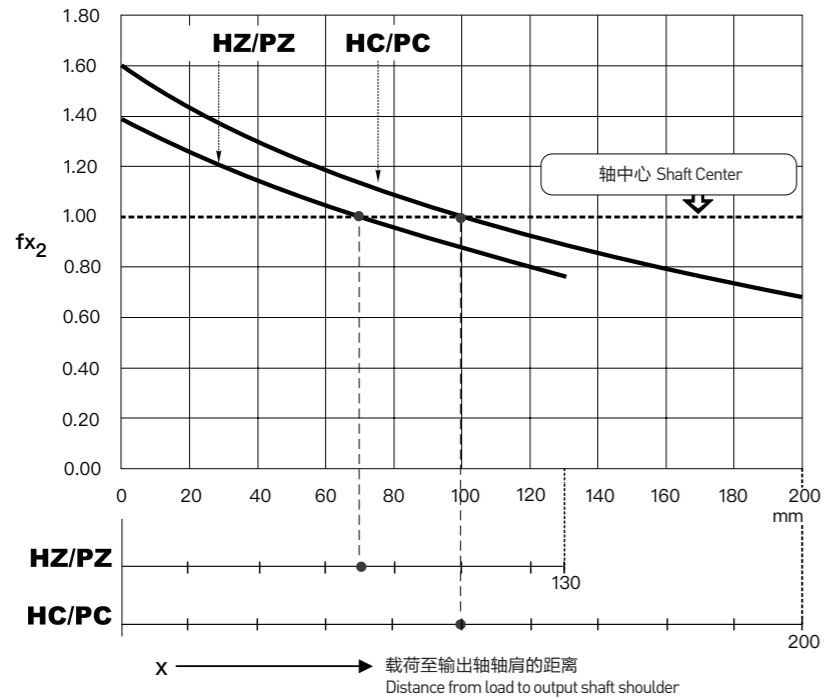

输入转速 $n_1=1000\text{min}^{-1}$ 且假设使用寿命=10000小时, 输入轴上的允许悬臂荷载。  
当输入转速和/或使用寿命不同于这里所列举的值时, 参见样本: 校核。  
Input speed  $n_1=1000\text{min}^{-1}$  and assuming a service life of 10000 hours, the allowable cantilever load on the input shaft.  
When the input speed and/or service life are different from the values listed here, refer to sample: verification.

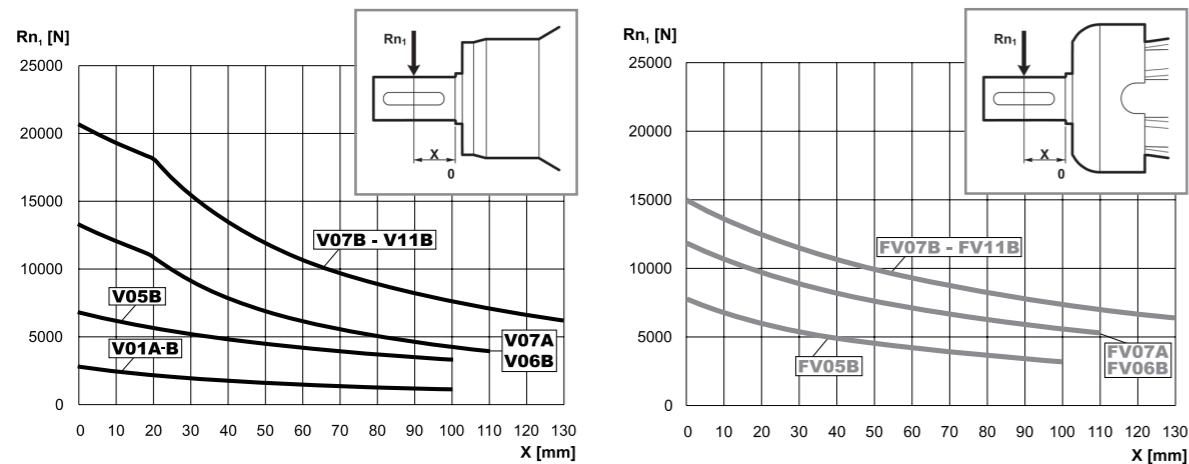

EQ314L

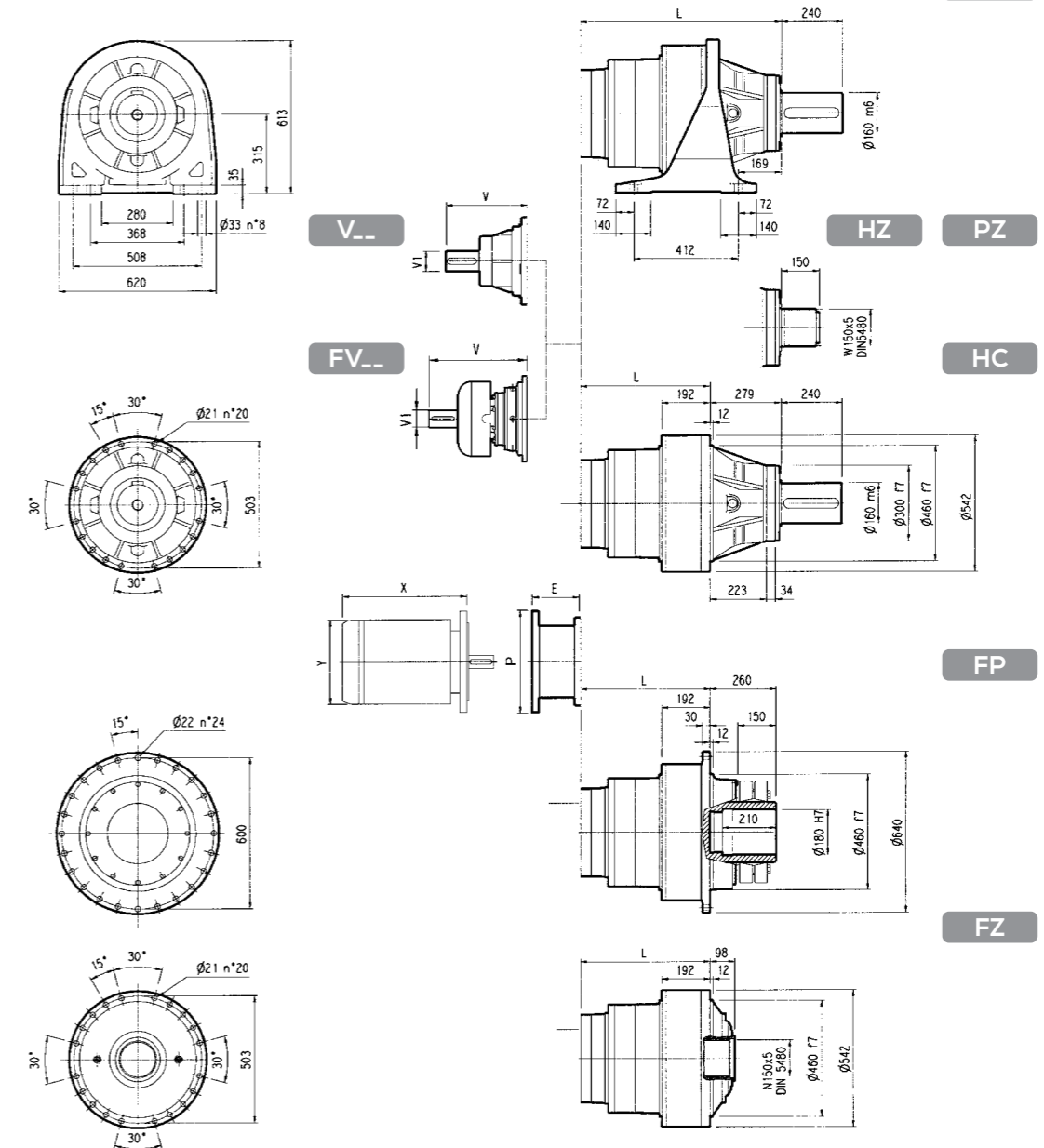

FP  $M_{2max} = 126000 \text{ Nm}$

	L				Kg				输入轴 Input Shaft				输入轴 Input Shaft			
	PC-PZ	HC-HZ	FZ	FP	PC-PZ	HC-HZ	FZ	FP	V	V1	V	V1	V	V1	V	V1
EQ314L2	641	362	362	362	545	325	325	375	377	80	50	-	-	457	80	63
EQ314L3	777	498	498	498	590	370	370	420	307	60	23	-	-	357	60	28
EQ314L4	842	563	563	563	600	380	380	430	239	48	15	-	-	276	48	17

	P132		P160		P180		P200		P225		P250	
	E	P	E	P	E	P	E	P	E	P	E	P
EQ314L2	-	-	-	-	-	-	271	400	301	450	281	550
EQ314L3	-	-	153	350	153	350	183	400	213	450	193	550
EQ314L4	114	300	144	350	144	350	174	400	-	-	-	-

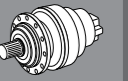
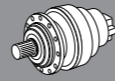

EQ314R

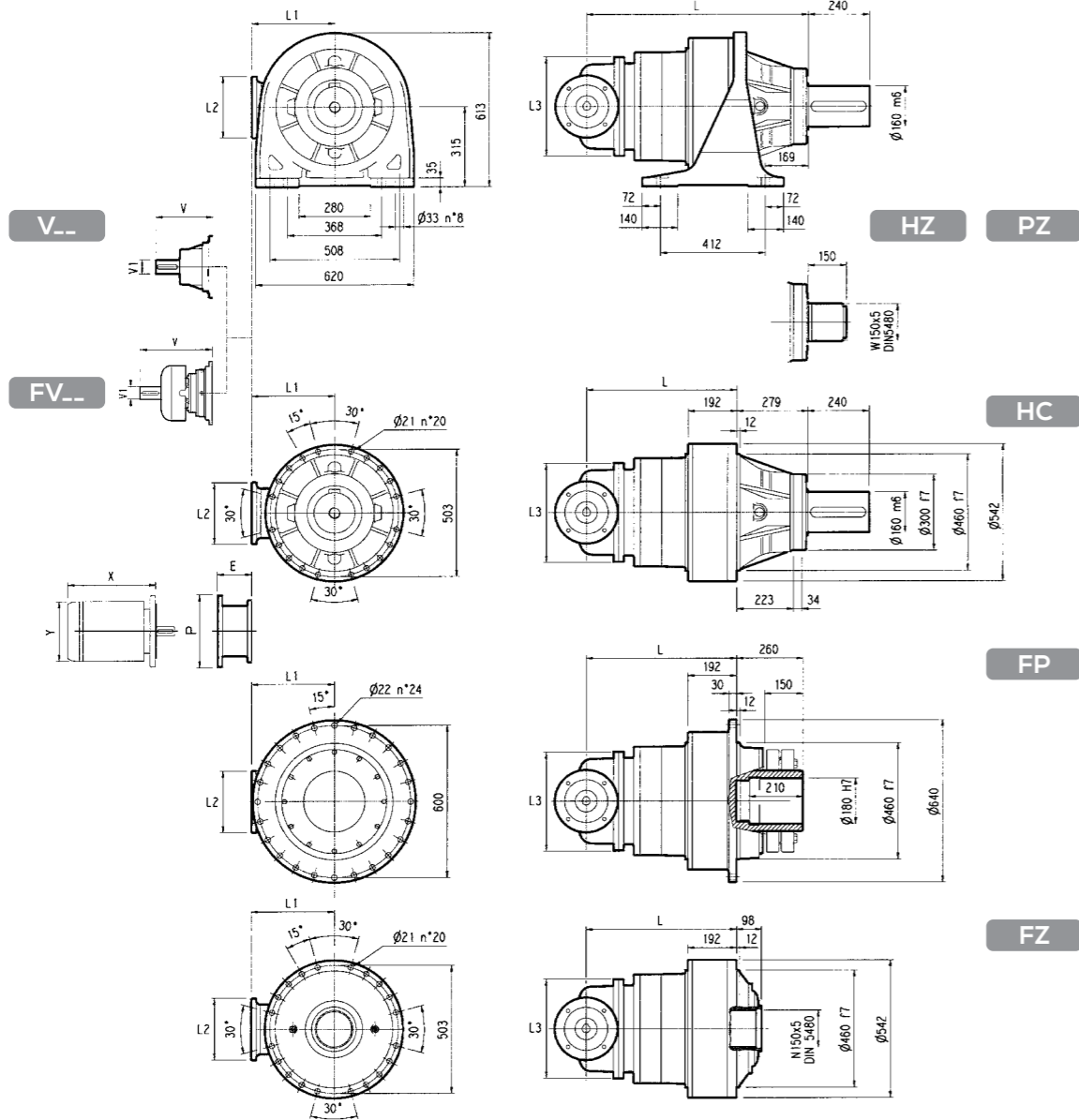

FP  $M_{2max} = 126000 \text{ Nm}$

	L				L1	L2	L3	Kg				输入轴 Input Shaft				输入轴 Input Shaft							
	PC-PZ	HC-HZ	FZ	FP				PC-PZ	HC-HZ	FZ	FP	V	V1	Kg	V	V1	Kg	V	V1	Kg			
EQ314R3(B)	848	569	569	569	345	292	400	720	590	500	550	307	60	23	-	-	-	357	60	28	-	-	-
EQ314R3(C)	856	587	587	587	390	292	480	730	600	510	560	307	60	23	-	-	-	357	60	28	-	-	-
EQ314R4	914	635	635	635	225	245	345	680	550	460	510	137.5	24	6	158	38	7	-	-	-	-	-	-

	P71		P80		P90		P100		P112		P132		P160		P180		P200		P225		P250	
	E	P	E	P	E	P	E	P	E	P	E	P	E	P	E	P	E	P	E	P	E	P
EQ314R3(B)	-	-	-	-	-	-	-	-	-	-	-	-	-	-	152	350	182	400	212	450	193	550
EQ314R3(C)	-	-	-	-	-	-	-	-	-	-	-	-	-	-	152	350	182	400	212	450	193	550
EQ314R4	65	160	84	200	84	200	94	250	94	250	114	300	144	350	-	-	-	-	-	-	-	-

EQ314L / ER314R

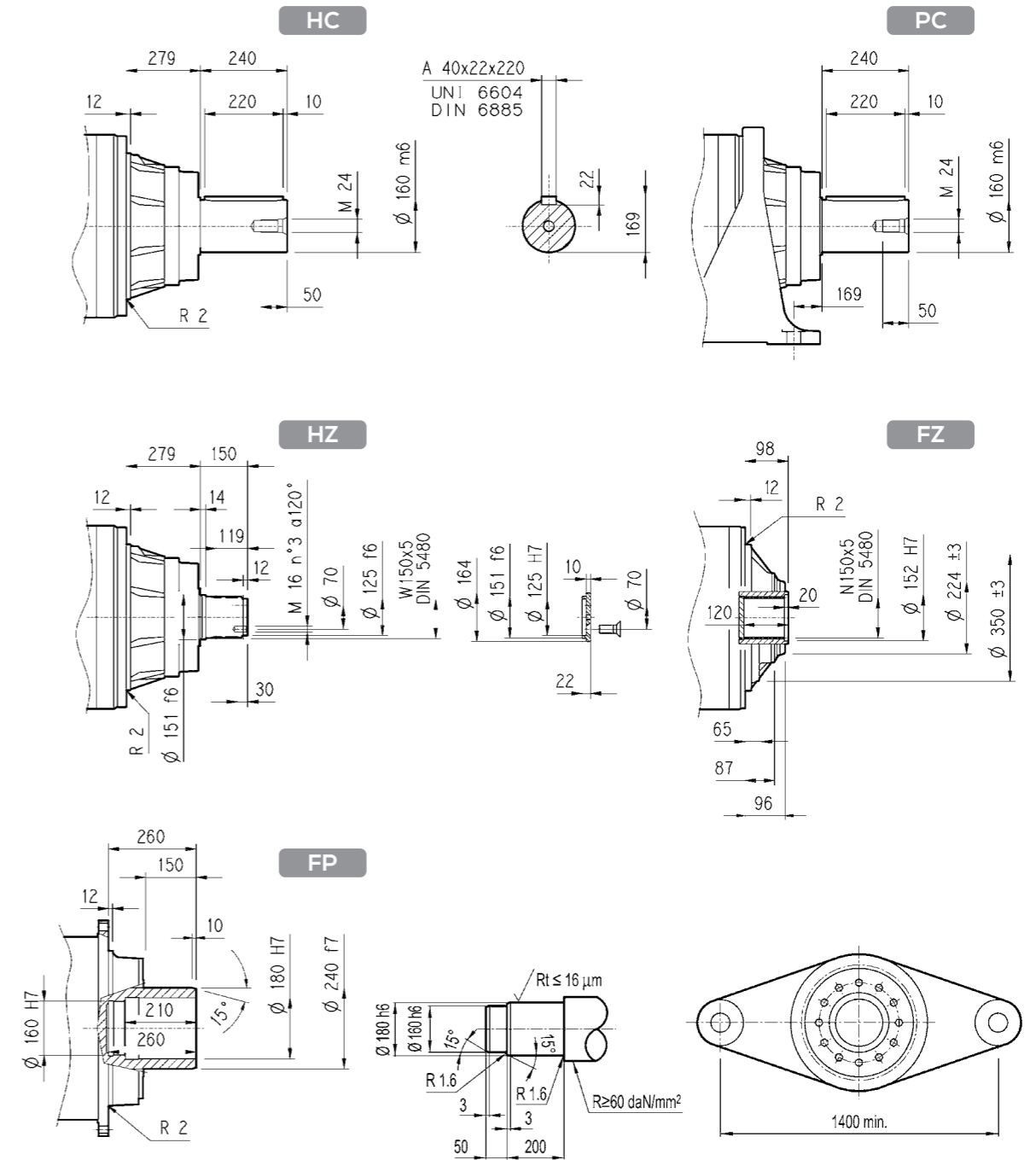

FP  $M_{2max} = 126000 \text{ Nm}$

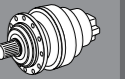
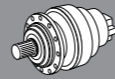

法兰 Flange

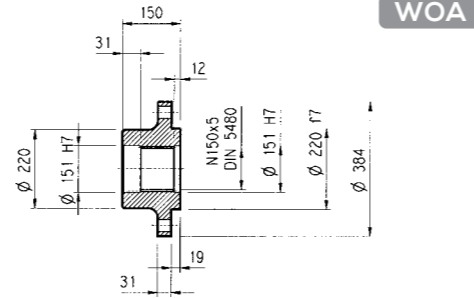
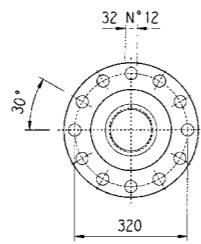
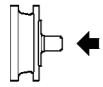

WOA

材料: 45#钢  
Material: 45 # steel

小齿轮 Pinion

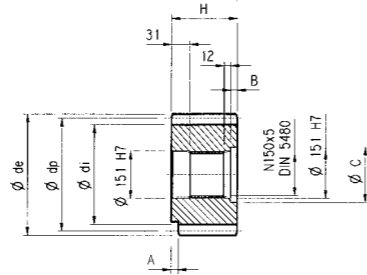

P...

	m	z	x	dp	di	de	H	A	B	C	☆
PRG1	18	16	0.500	288	261	342	160	0	10	166	■
PRG2	18	16	0.617	288	271	339	150	30	0	0	□

☆ 材料 Material  
□ 42CrMo钢调质 42CrMo steel quenched and tempered  
■ 20CrMnTi钢表面渗碳 Surface carburizing of 20CrMnTi steel

套筒联轴节 Sleeve Coupling

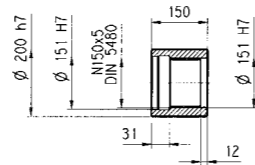

MOA

材料: 42CrMo钢  
Material: 42CrMo steel

花键棒 Spline Bar

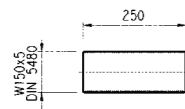
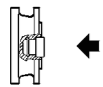

BOA

材料: 42CrMo钢表面硬度HRC45-55  
Material: 42CrMo steel surface hardness HRC45-55

收缩盘 Shrink Disk

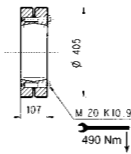
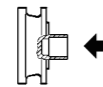

GOA

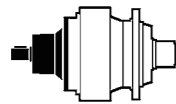

	Input	V	V1	V2	V4	V5	A	B	F	L	S	D	U
EQ314L2	V10B	377	80	130	200	400	22	14	85	110	10	M16	36
	FV10B	457	80	130	347.5	400	22	14	85	110	10	M16	36
EQ314L3	V06B	307	60	105	155	292	18	11	64	90	7.5	M16	36
	FV06B	357	60	105	309	292	18	11	64	90	7.5	M16	36
EQ314L4	V05B	239	48	82	155	245	14	9	51.5	70	6	M16	36
	FV05B	276	48	82	219.5	244	14	9	51.5	70	6	M16	36
EQ314R3(B)(C)	V06B	307	60	105	155	292	18	11	64	90	7.5	M16	36
	FV06B	357	60	105	309	292	18	11	64	90	7.5	M16	36
EQ314R4	VO1A	137.5	24	36	120	186	8	7	27	30	3	M8	19
	VO1B	158	38	58	120	186	10	8	41	50	4	M12	28

V...

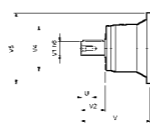

FV...

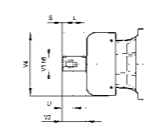

输出轴上的径向载荷位置系数

RADIAL LOAD POSITION COEFFICIENT ON OUTPUT SHAFT

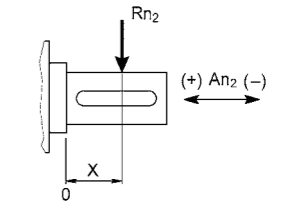
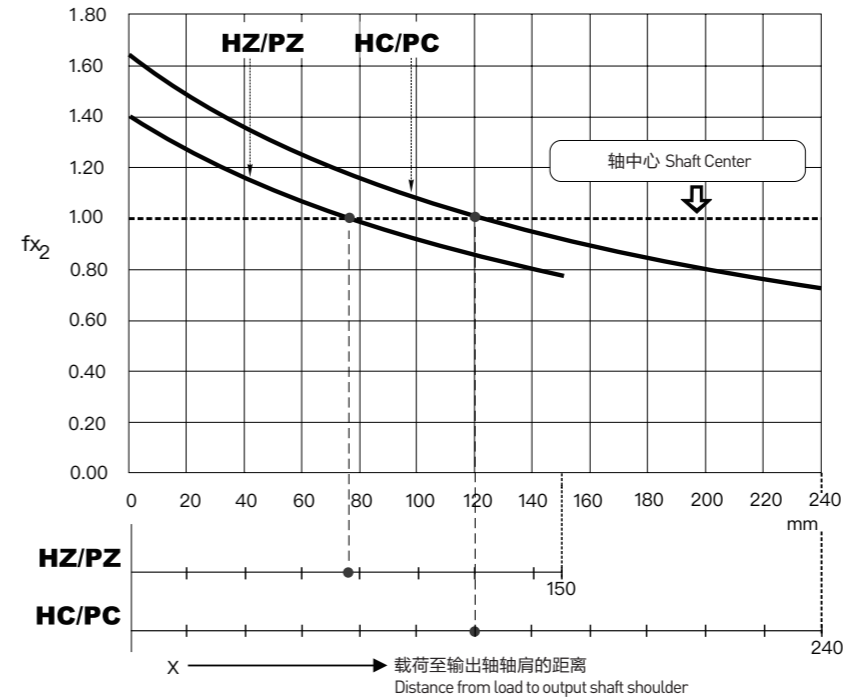

$R_{x2} = R_{n2} \cdot f_{x2}$

$A_{n2} (\pm) = R_{n2} \cdot f_{a2} (\pm)$		
	$f_{a2} (+)$	$f_{a2} (-)$
HZ/PZ	1.15	0.86
HC/PC	1.36	1.02

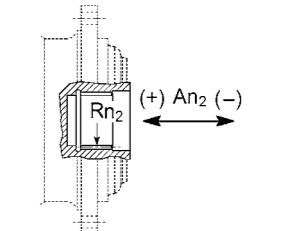

$A_{n2} (\pm) = R_{n2} \cdot f_{a2} (\pm)$		
	$f_{a2} (+)$	$f_{a2} (-)$
FZ	1.00	1.00

输入转速 $n_1=1000\text{min}^{-1}$ 且假设使用寿命=10000小时, 输入轴上的允许悬臂荷载。  
当输入转速和/或使用寿命不同于这里所列举的值时, 参见样本: 校核。  
Input speed  $n_1=1000\text{min}^{-1}$  and assuming a service life of 10000 hours, the allowable cantilever load on the input shaft.  
When the input speed and/or service life are different from the values listed here, refer to sample: verification.

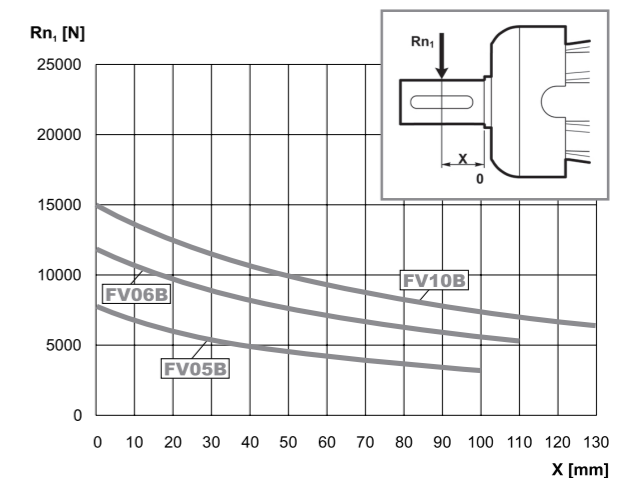
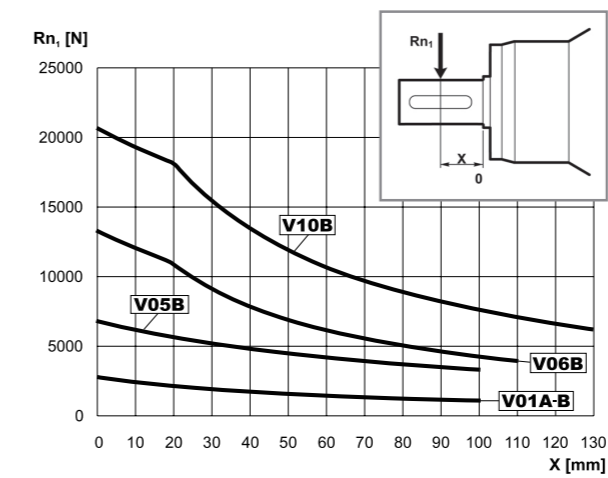

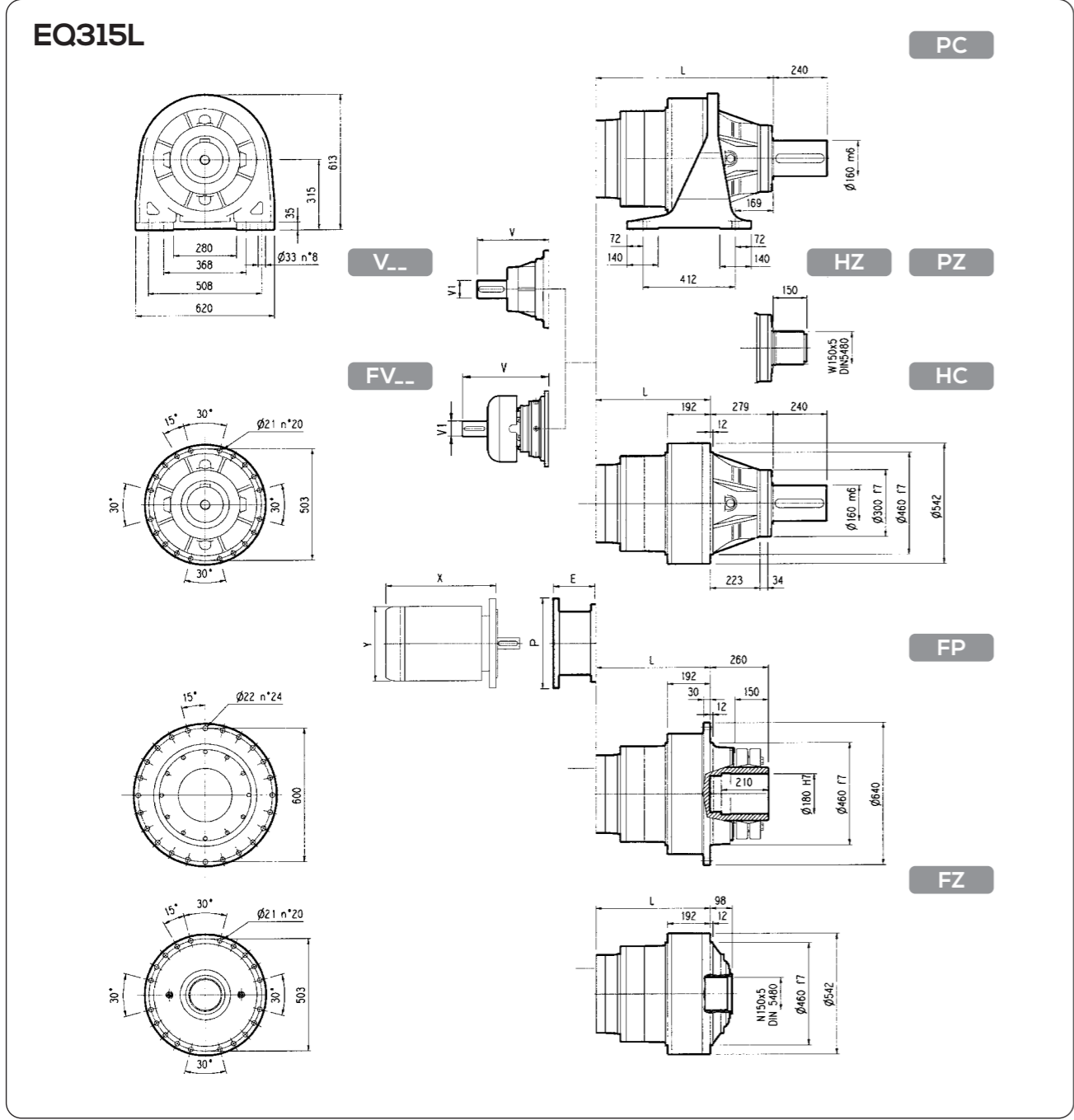
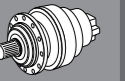
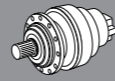

**FP**  $M_{2max} = 126000 \text{ Nm}$

	L				Kg				输入轴 Input Shaft				输入轴 Input Shaft								
	PC-PZ	HC-HZ	FZ	FP	PC-PZ	HC-HZ	FZ	FP	V	V1	Kg	V	V1	Kg	V	V1	Kg	V	V1	Kg	
EQ315L2	665	386	386	386	585	455	365	415	348	80	55	-	-	-	456	80	85	-	-	-	-
EQ315L3	798	519	519	519	630	500	410	460	315	80	35	313	60	28	375	80	48	363	60	34	-
EQ315L4	887	608	608	608	642	512	422	472	239	48	15	-	-	-	276	48	17	-	-	-	-

	P132		P160		P180		P200		P225		P250	
	E	P	E	P	E	P	E	P	E	P	E	P
EQ315L3	-	-	-	-	195	350	186	400	216	450	251	550
EQ315L4	114	300	144	350	144	350	174	400	-	-	-	-

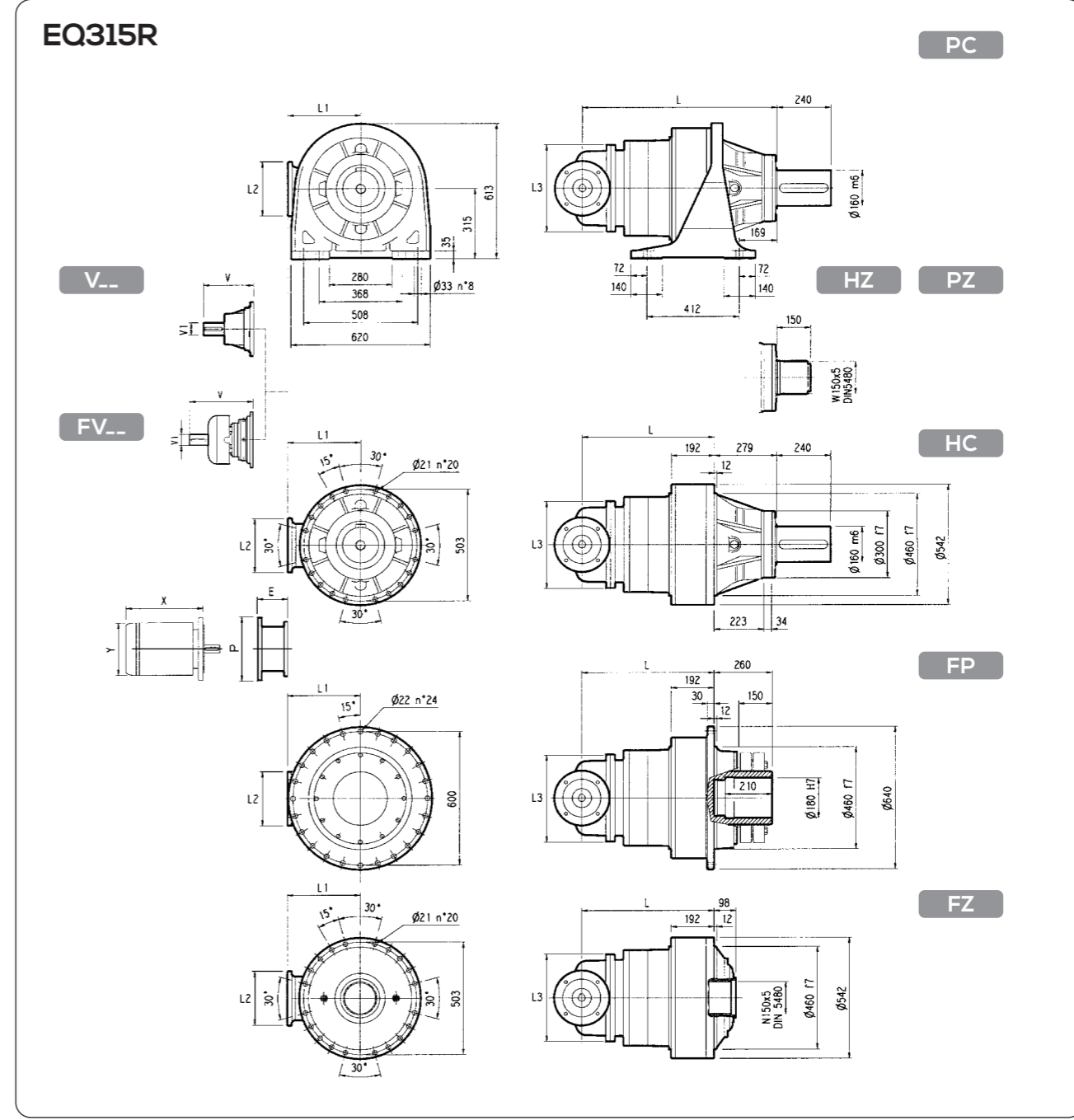

**FP**  $M_{2max} = 126000 \text{ Nm}$

	L				L1	L2	L3	Kg				输入轴 Input Shaft				输入轴 Input Shaft						
	PC-PZ	HC-HZ	FZ	FP				PC-PZ	HC-HZ	FZ	FP	V	V1	Kg	V	V1	Kg	V	V1	Kg	V	V1
EQ315R3(B)	890	611	611	611	345	292	400	720	590	500	550	307	60	23	-	-	-	357	60	28	-	-
EQ315R3(C)	890	611	611	611	390	292	480	730	600	510	560	307	60	23	-	-	-	357	60	28	-	-
EQ315R4	917	638	638	638	225	245	345	680	550	460	510	137.5	24	15	-	-	-	276	48	17	-	-

	P132		P160		P180		P200		P225		P250	
	E	P	E	P	E	P	E	P	E	P	E	P
EQ315R3(B)	-	-	-	-	152	350	182	400	212	450	193	550
EQ315R3(C)	-	-	-	-	152	350	182	400	212	450	193	550
EQ315R4	114	300	144	350	144	350	174	400	-	-	-	-

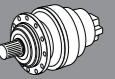
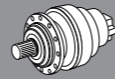

EQ315L / ER315R

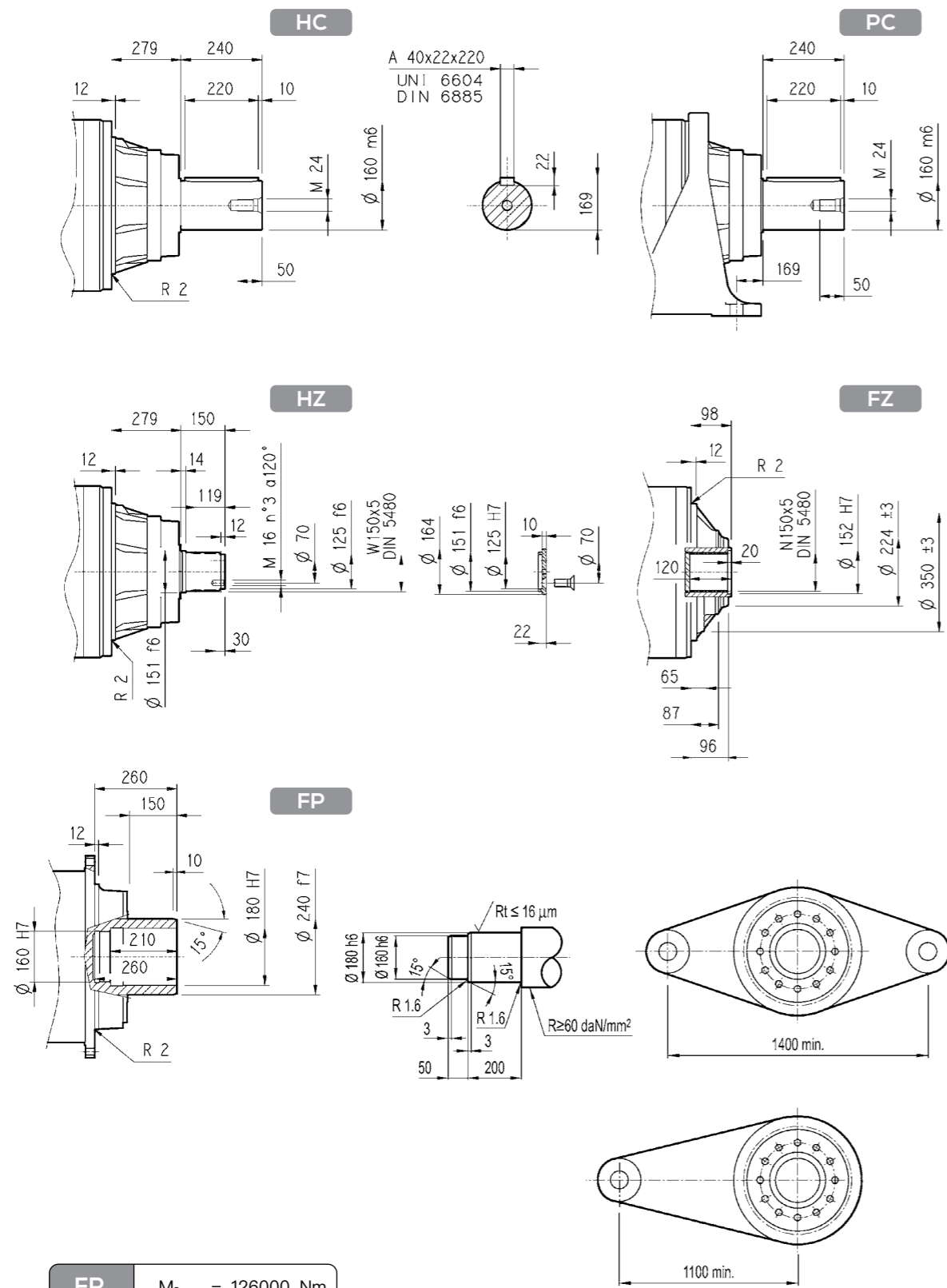

法兰 Flange

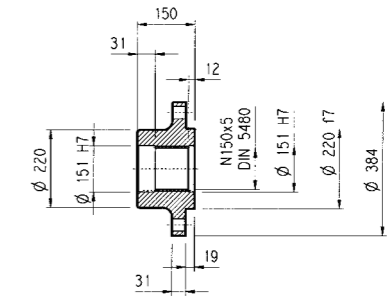
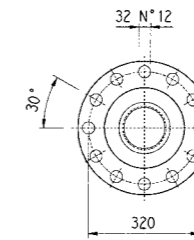
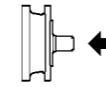

WOA

材料: 45#钢  
Material: 45 # steel

小齿轮 Pinion

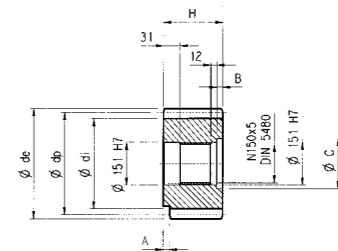

P...

	m	z	x	dp	di	de	H	A	B	C	☆	☆ 材料 Material
PRG1	18	16	0.500	288	261	342	160	0	10	166	■	□ 42CrMo钢调质 42CrMo steel quenched and tempered
PRG2	18	16	0.617	288	271	339	150	30	0	0	□	■ 20CrMnTi钢表面渗碳 Surface carburizing of 20CrMnTi steel

套筒联轴节 Sleeve Coupling

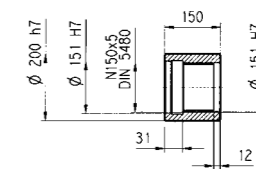

MOA

材料: 42CrMo钢  
Material: 42CrMo steel

花键棒 Spline Bar

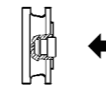

BOA



材料: 42CrMo钢表面硬度HRC45-55  
Material: 42CrMo steel surface hardness HRC45-55

收缩盘 Shrink Disk

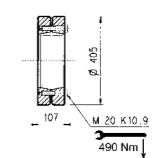
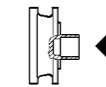

GOA

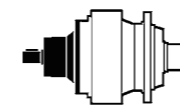

	Input	V	V1	V2	V4	V5	A	B	F	L	S	D	U
EQ315L2	V11B	348	80	130	200	418	22	14	85	110	10	M16	36
	FV11B	456	80	130	347.5	428	22	14	85	110	10	M16	36
EQ315L3	V07B	315	80	130	200	345	22	14	85	110	10	M16	36
	FV07B	375	80	130	347.5	348	22	14	85	110	10	M16	36
	VO7A	313	60	105	155	345	18	11	64	90	7.5	M16	36
EQ315L4	FV07A	363	60	105	309	348	18	11	64	90	7.5	M16	36
	V05B	239	48	82	155	245	14	9	51.5	70	6	M16	36
EQ315R3(B)(C)	FV05B	276	48	82	219.5	244	14	9	51.5	70	6	M16	36
	VO6B	307	60	105	155	292	18	11	64	90	7.5	M16	36
EQ315R4	FV06B	357	60	105	309	292	18	11	64	90	7.5	M16	36
	V05B	239	48	82	155	245	14	9	51.5	70	6	M16	36
	FV05B	276	48	82	219.5	244	14	9	51.5	70	6	M16	36

V...

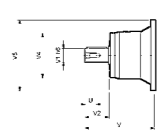

FV...

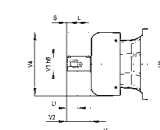

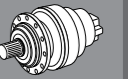
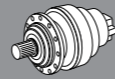

输出轴上的径向载荷位置系数  
RADIAL LOAD POSITION COEFFICIENT ON OUTPUT SHAFT

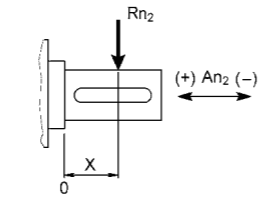
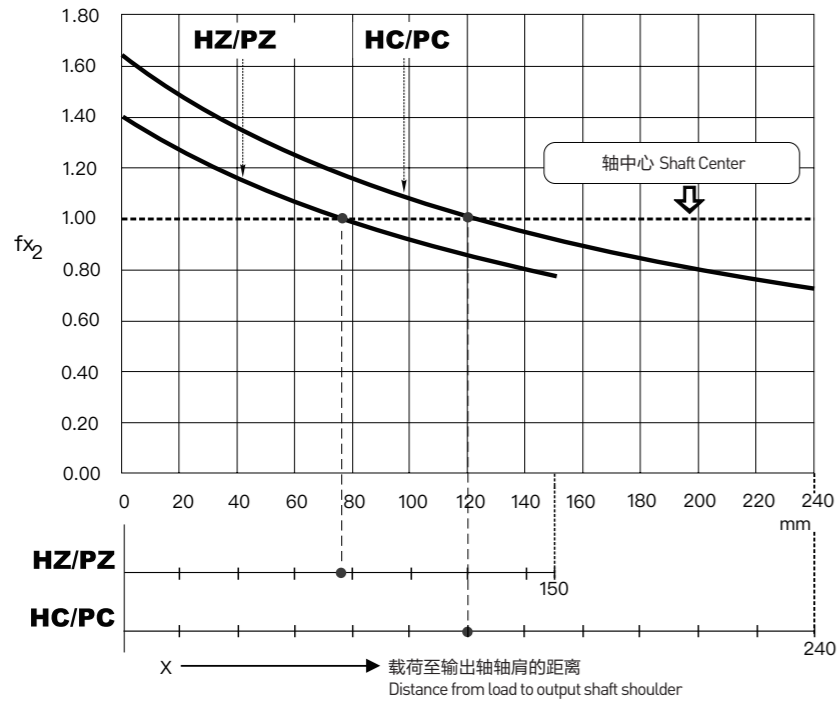

$$R_{x2} = R_{n2} \cdot f_{x2}$$

$$A_{n2} (\pm) = R_{n2} \cdot f_{a2} (\pm)$$

	$f_{a2} (+)$	$f_{a2} (-)$
HZ/PZ	1.15	0.86
HC/PC	1.36	1.02

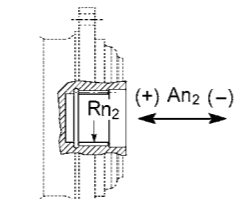

$$A_{n2} (\pm) = R_{n2} \cdot f_{a2} (\pm)$$

	$f_{a2} (+)$	$f_{a2} (-)$
FZ	1.00	1.00

输入转速 $n_1=1000\text{min}^{-1}$ 且假设使用寿命=10000小时, 输入轴上的允许悬臂荷载。  
当输入转速和/或使用寿命不同于这里所列举的值时, 参见样本: 校核。

Input speed  $n_1=1000\text{min}^{-1}$  and assuming a service life of 10000 hours, the allowable cantilever load on the input shaft.  
When the input speed and/or service life are different from the values listed here, refer to sample: verification.

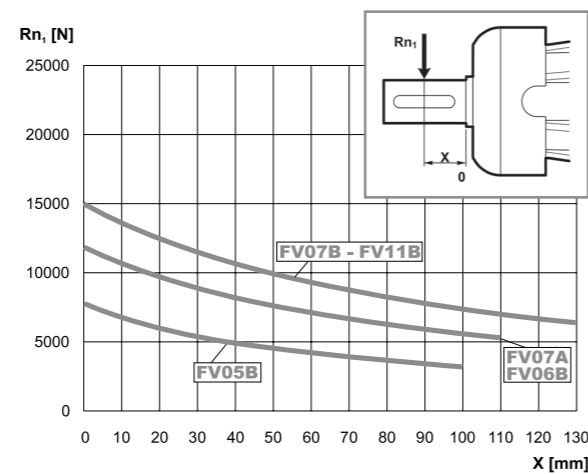
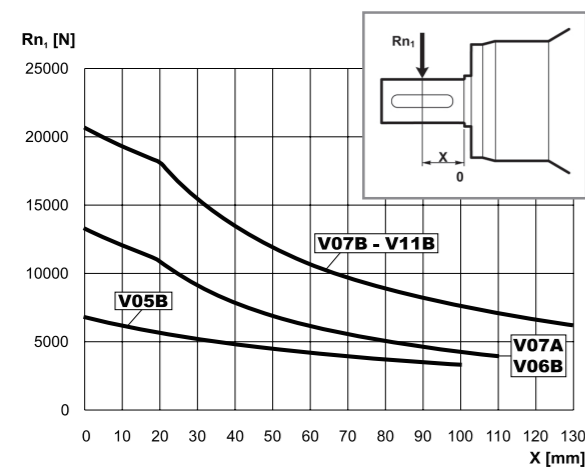

EQ316L

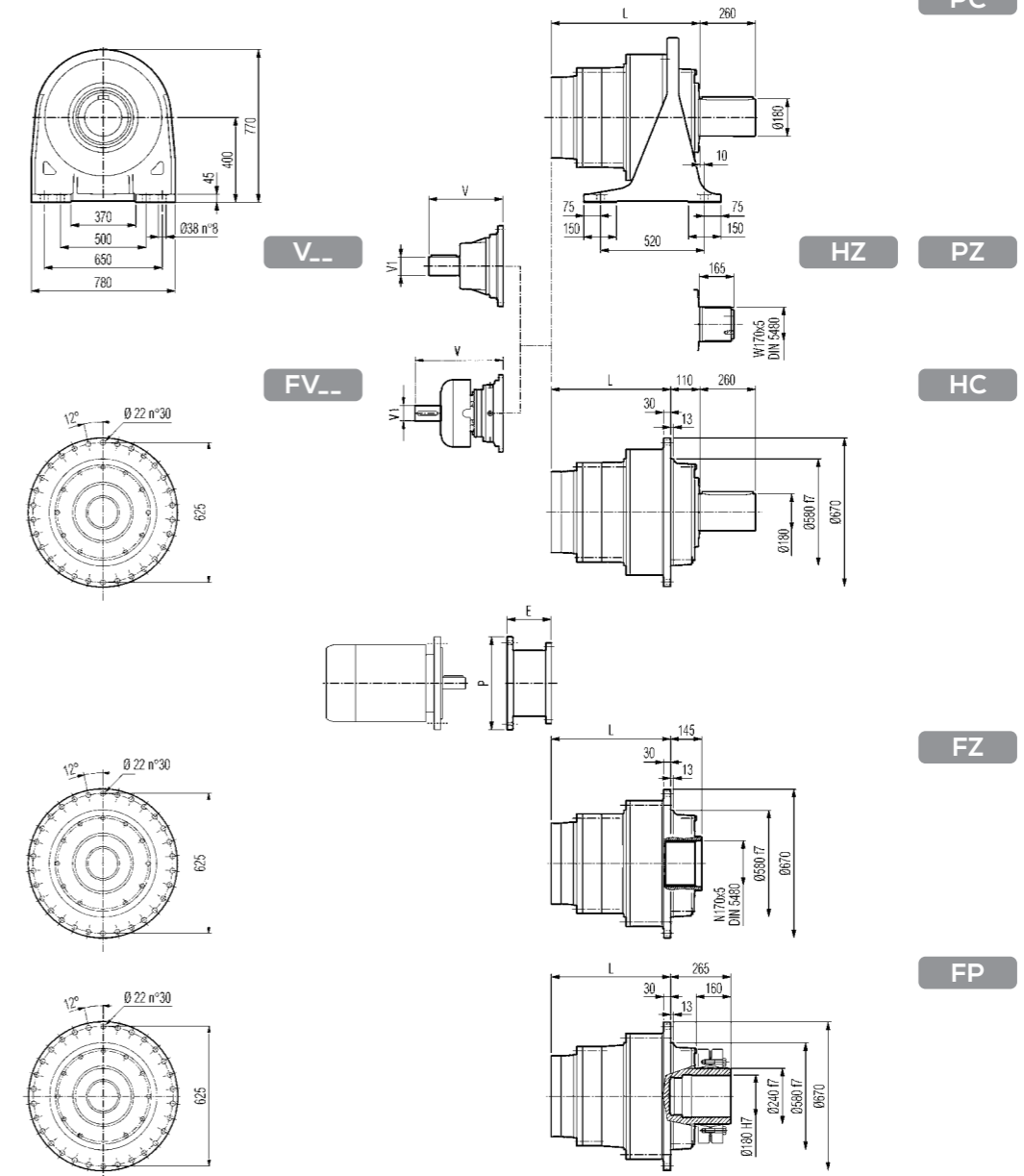

FP  $M_{2max} = 162000 \text{ Nm}$

	L				$\text{Kg}$				输入轴 Input Shaft $\text{Kg}$				输入轴 Input Shaft $\text{Kg}$					
	PC-PZ	HC-HZ	FZ	FP	PC-PZ	HC-HZ	FZ	FP	V	V1	$\text{Kg}$	V	V1	$\text{Kg}$	V	V1	$\text{Kg}$	
EQ316L2	665	386	386	386	585	455	365	415	348	80	55	-	-	-	456	80	85	-
EQ316L3	798	519	519	519	630	500	410	460	315	80	35	313	60	28	375	80	48	363
EQ316L4	887	608	608	608	642	512	422	472	239	48	15	-	-	-	276	48	17	-

	P132		P160		P180		P200		P225		P250	
	E	P	E	P	E	P	E	P	E	P	E	P
EQ316L3	-	-	-	-	195	350	186	400	216	450	251	550
EQ316L4	114	300	144	350	144	350	174	400	-	-	-	-

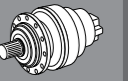
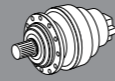

EQ316R

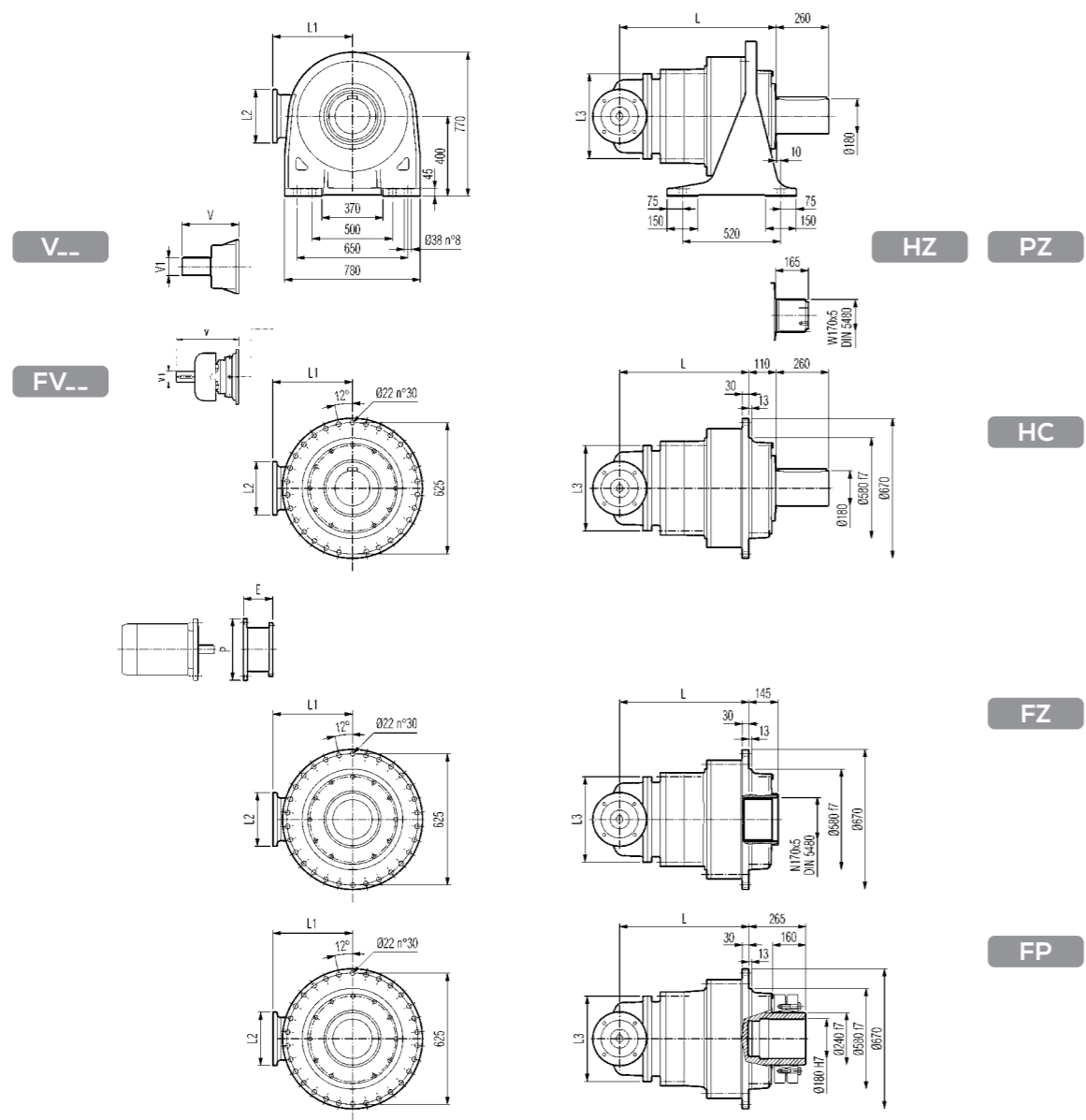

FP  $M_{2max} = 162000 \text{ Nm}$

	L				L1	L2	L3	Kg				输入轴 Input Shaft				输入轴 Input Shaft							
	PC-PZ	HC-HZ	FZ	FP				PC-PZ	HC-HZ	FZ	FP	V	V1	Kg	V	V1	Kg	V	V1	Kg			
EQ316R3(B)	766	656	656	656	345	292	400	910	710	640	660	307	60	23	-	-	-	357	60	28	-	-	-
EQ316R3(C)	766	656	656	656	390	292	480	920	720	650	670	307	60	23	-	-	-	357	60	28	-	-	-
EQ316R4	793	683	683	683	225	245	345	890	690	620	640	239	48	15	-	-	-	276	48	17	-	-	-

	P132		P160		P180		P200		P225		P250	
	E	P	E	P	E	P	E	P	E	P	E	P
EQ316R3(B)	-	-	-	-	152	350	182	400	212	450	193	550
EQ316R3(C)	-	-	-	-	152	350	182	400	212	450	193	550
EQ316R4	114	300	144	350	144	350	174	400	-	-	-	-

EQ316L / ER316R

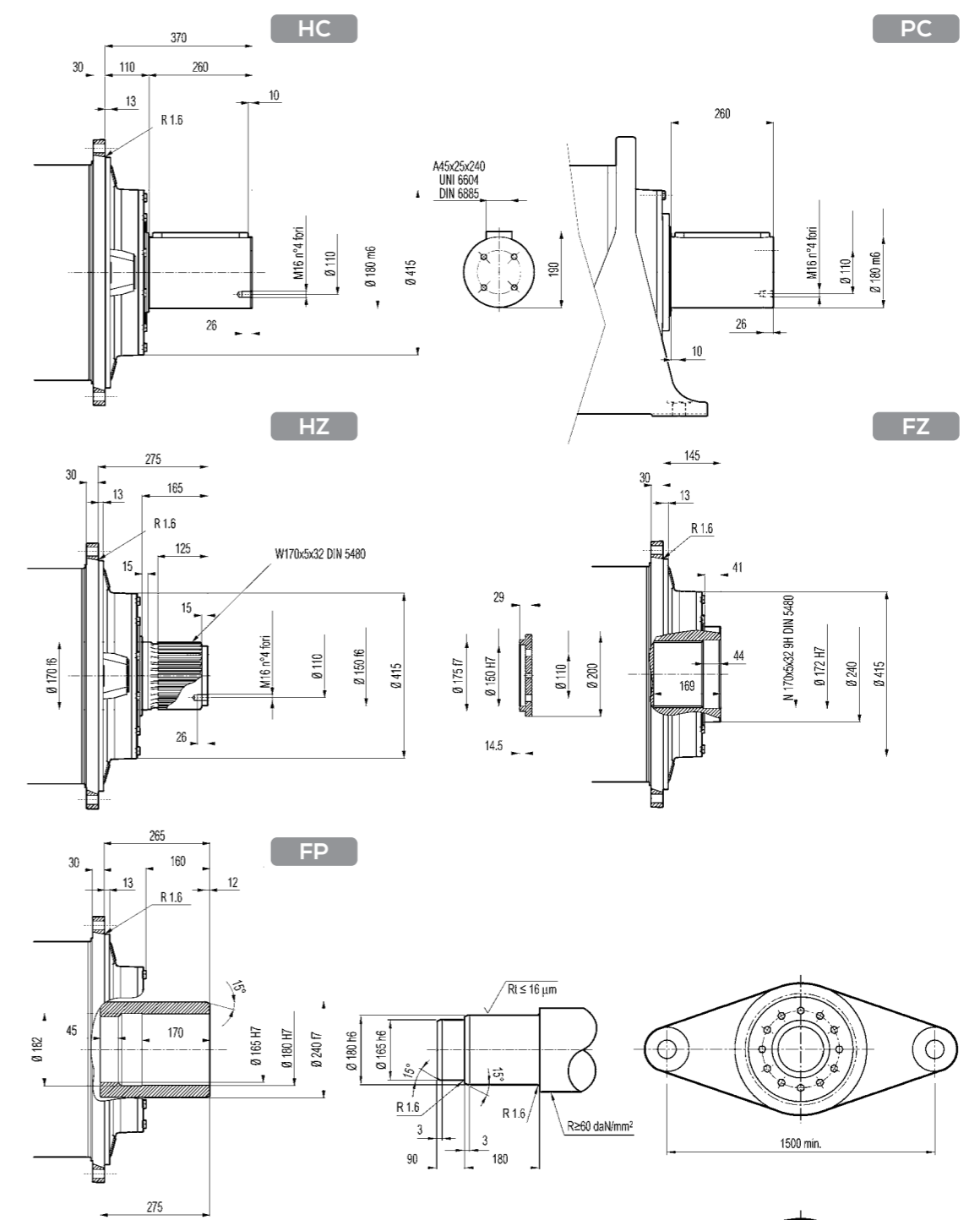

FP  $M_{2max} = 162000 \text{ Nm}$

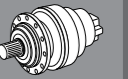
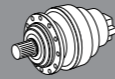

法兰 Flange

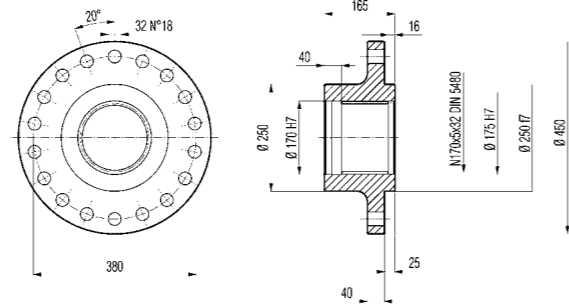
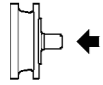

WOA

材料: 45#钢  
Material: 45 # steel

套筒联轴节 Sleeve Coupling

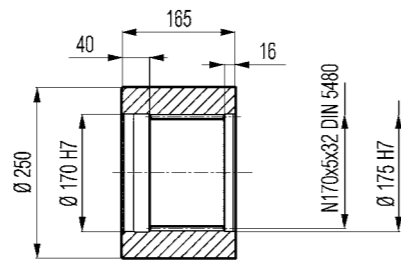

MOA

材料: 42CrMo钢  
Material: 42CrMo steel

花键棒 Spline Bar

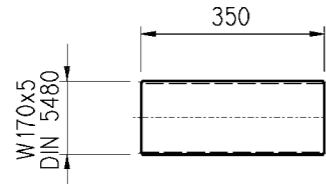
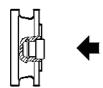

BOA

材料: 42CrMo钢表面硬度HRC45-55  
Material: 42CrMo steel surface hardness HRC45-55

收缩盘 Shrink Disk

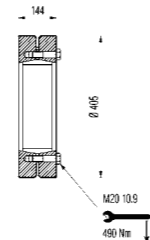
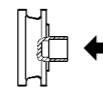

GOA

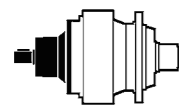

	Input	V	V1	V2	V4	V5	A	B	F	L	S	D	U
EQ316L2	V11B	348	80	130	200	418	22	14	85	110	10	M16	36
	FV11B	456	80	130	347.5	428	22	14	85	110	10	M16	36
	V07B	315	80	130	200	345	22	14	85	110	10	M16	36
EQ316L3	FV07B	375	80	130	347.5	348	22	14	85	110	10	M16	36
	VO7A	313	60	105	155	345	18	11	64	90	7.5	M16	36
	FV07A	363	60	105	309	348	18	11	64	90	7.5	M16	36
EQ316L4	V05B	239	48	82	155	245	14	9	51.5	70	6	M16	36
	FV05B	276	48	82	219.5	244	14	9	51.5	70	6	M16	36
EQ316R3(B)(C)	VO6B	307	60	105	155	292	18	11	64	90	7.5	M16	36
	FV06B	357	60	105	309	292	18	11	64	90	7.5	M16	36
EQ316R4	V05B	239	48	82	155	245	14	9	51.5	70	6	M16	36
	FV05B	276	48	82	219.5	244	14	9	51.5	70	6	M16	36

V\_ \_

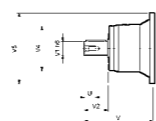

FV\_ \_

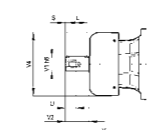

输出轴上的径向载荷位置系数

RADIAL LOAD POSITION COEFFICIENT ON OUTPUT SHAFT

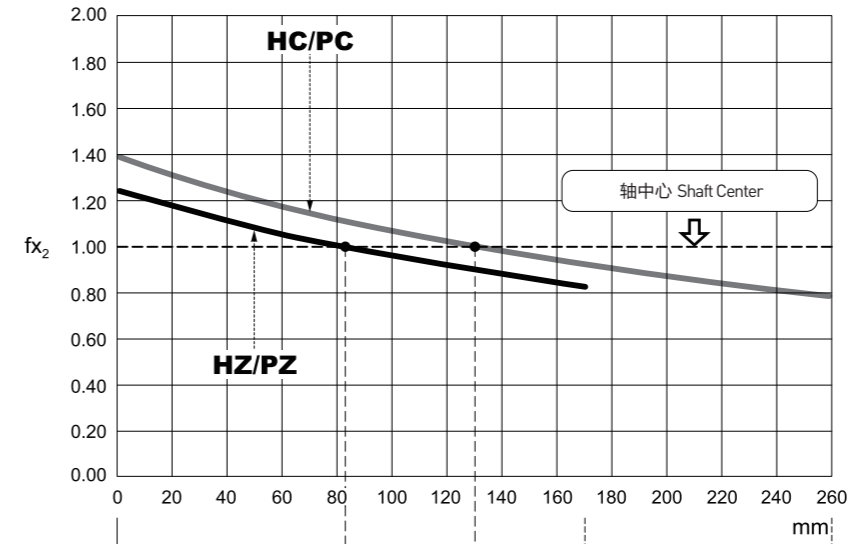

HZ/PZ  
HC/PC

X → 载荷至输出轴轴肩的距离  
Distance from load to output shaft shoulder

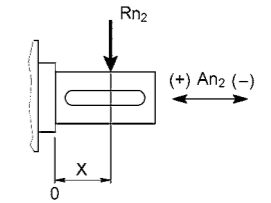

$$R_{x2} = R_{n2} \cdot f_{x2}$$

$$A_{n2} (\pm) = R_{n2} \cdot f_{a2} (\pm)$$

	$f_{a2} (+)$	$f_{a2} (-)$
HZ/PZ	0.81	0.76
HC/PC	0.73	0.69

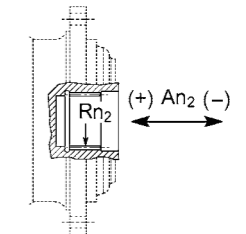

$$A_{n2} (\pm) = R_{n2} \cdot f_{a2} (\pm)$$

	$f_{a2} (+)$	$f_{a2} (-)$
FZ	0.92	0.92

输入转速 $n_1=1000\text{min}^{-1}$ 且假设使用寿命=10000小时, 输入轴上的允许悬臂荷载。

当输入转速和/或使用寿命不同于这里所列举的值时, 参见样本: 校核。

Input speed  $n_1=1000\text{min}^{-1}$  and assuming a service life of 10000 hours, the allowable cantilever load on the input shaft.

When the input speed and/or service life are different from the values listed here, refer to sample: verification.

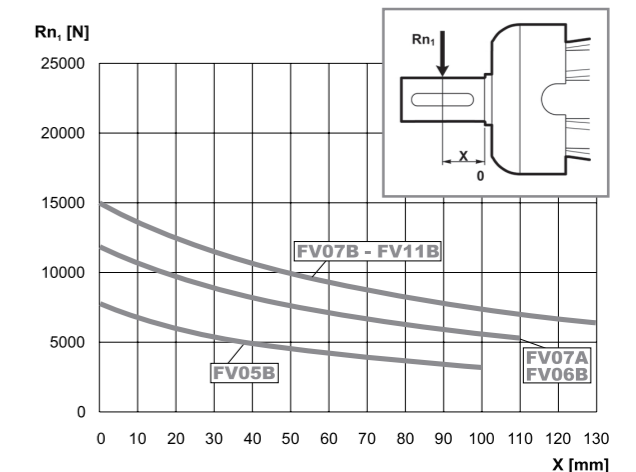
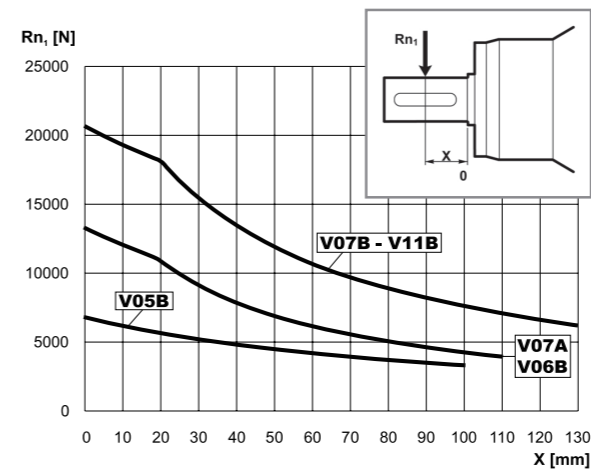

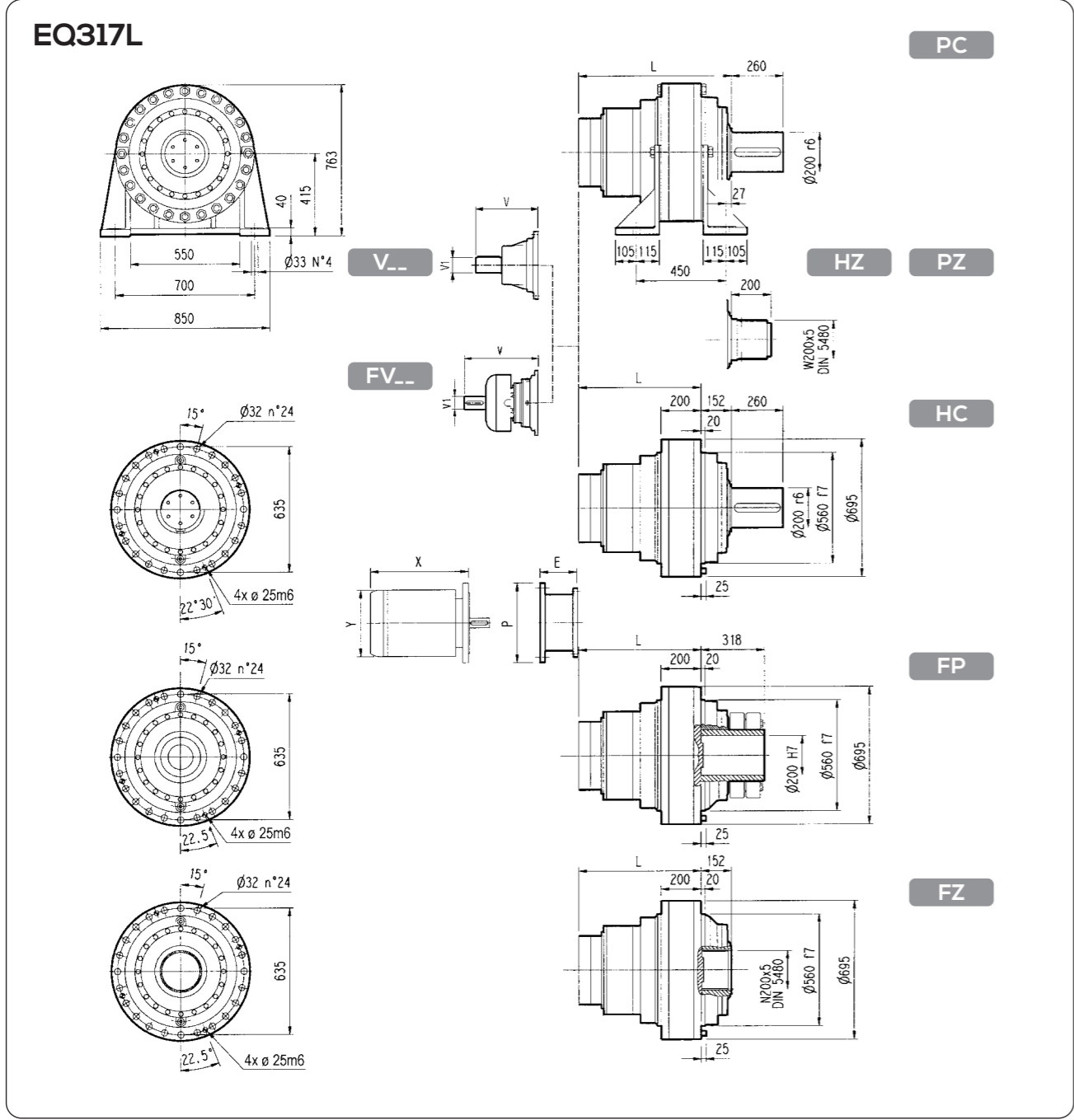
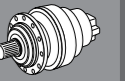
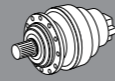

**FP**  $M_{2max} = 216000 \text{ Nm}$

	L				Kg				输入轴 Input Shaft				输入轴 Input Shaft							
	PC-PZ	HC-HZ	FZ	FP	PC-PZ	HC-HZ	FZ	FP	V	V1	Kg	V	V1	Kg	V	V1	Kg	V	V1	Kg
EQ317L2	624	475	475	475	1080	930	880	930	343	80	55	-	-	-	451	80	71	-	-	-
EQ317L3	774	622	622	622	1140	990	940	990	315	80	35	313	60	28	375	80	48	363	60	34
EQ317L4	862	710	710	710	1152	1000	952	1000	239	48	15	-	-	-	276	48	17	-	-	-

	P132		P160		P180		P200		P225		P250	
	E	P	E	P	E	P	E	P	E	P	E	P
EQ317L3	-	-	-	-	196	350	186	400	216	450	216	550
EQ317L4	114	300	144	350	144	350	174	400	-	-	-	-

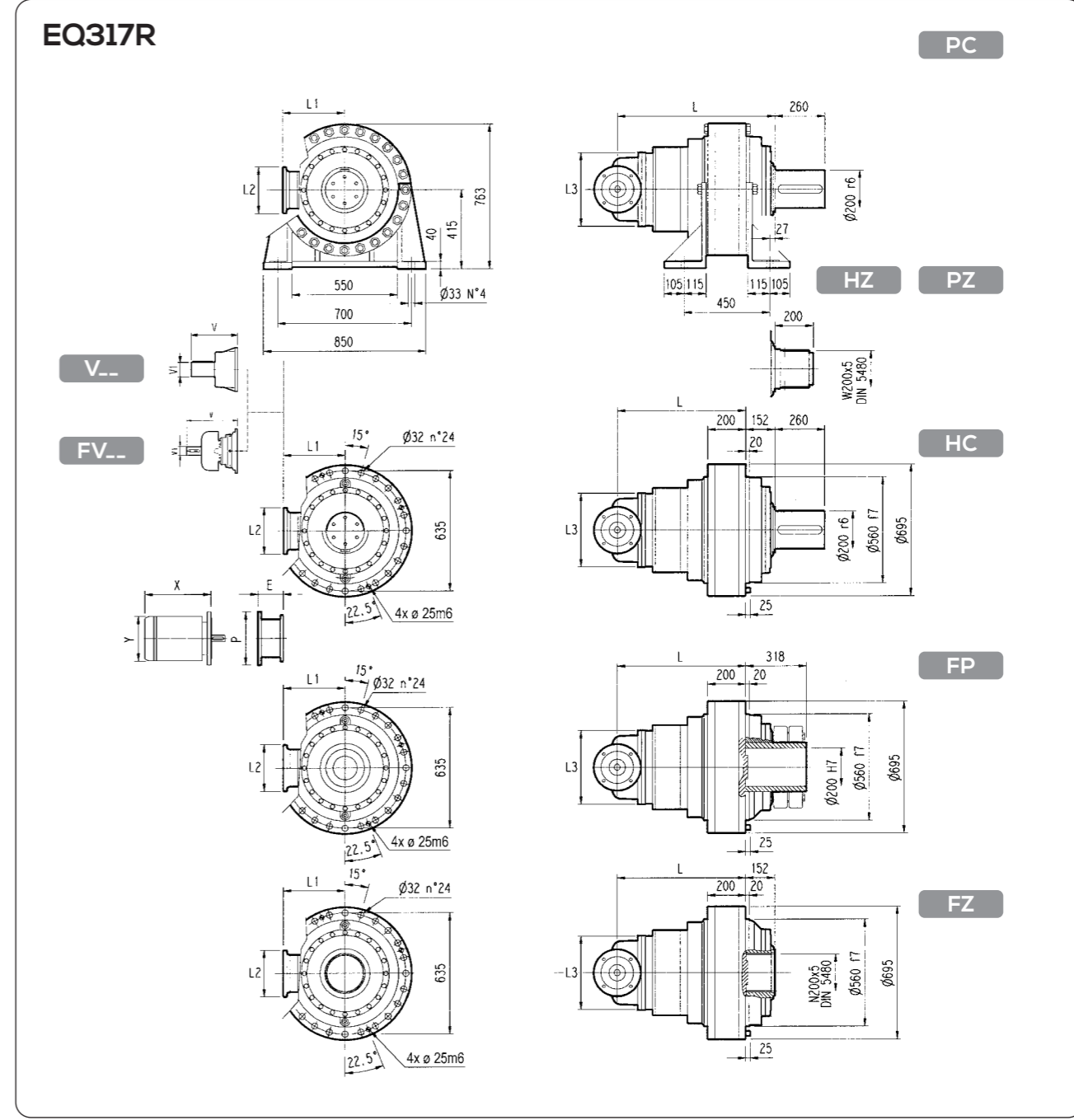

**FP**  $M_{2max} = 216000 \text{ Nm}$

	L				L1	L2	L3	Kg				输入轴 Input Shaft				输入轴 Input Shaft						
	PC-PZ	HC-HZ	FZ	FP				PC-PZ	HC-HZ	FZ	FP	V	V1	Kg	V	V1	Kg	V	V1	Kg	V	V1
EQ317R3(B)	853	701	701	701	345	292	400	1210	1060	1010	1060	307	60	23	-	-	-	357	60	28	-	-
EQ317R3(C)	853	701	701	701	390	292	480	1220	1070	1020	1070	307	60	23	-	-	-	357	60	28	-	-
EQ317R4	892	740	740	740	225	245	345	1190	1040	990	1040	239	48	15	-	-	-	276	48	17	-	-

	P132		P160		P180		P200		P225		P250	
	E	P	E	P	E	P	E	P	E	P	E	P
EQ317R3(B)	-	-	-	-	152	350	182	400	212	450	193	550
EQ317R3(C)	-	-	-	-	152	350	182	400	212	450	193	550
EQ317R4	114	300	144	350	144	350	174	400	-	-	-	-

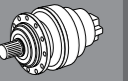
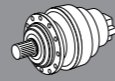

EQ317L / ER317R

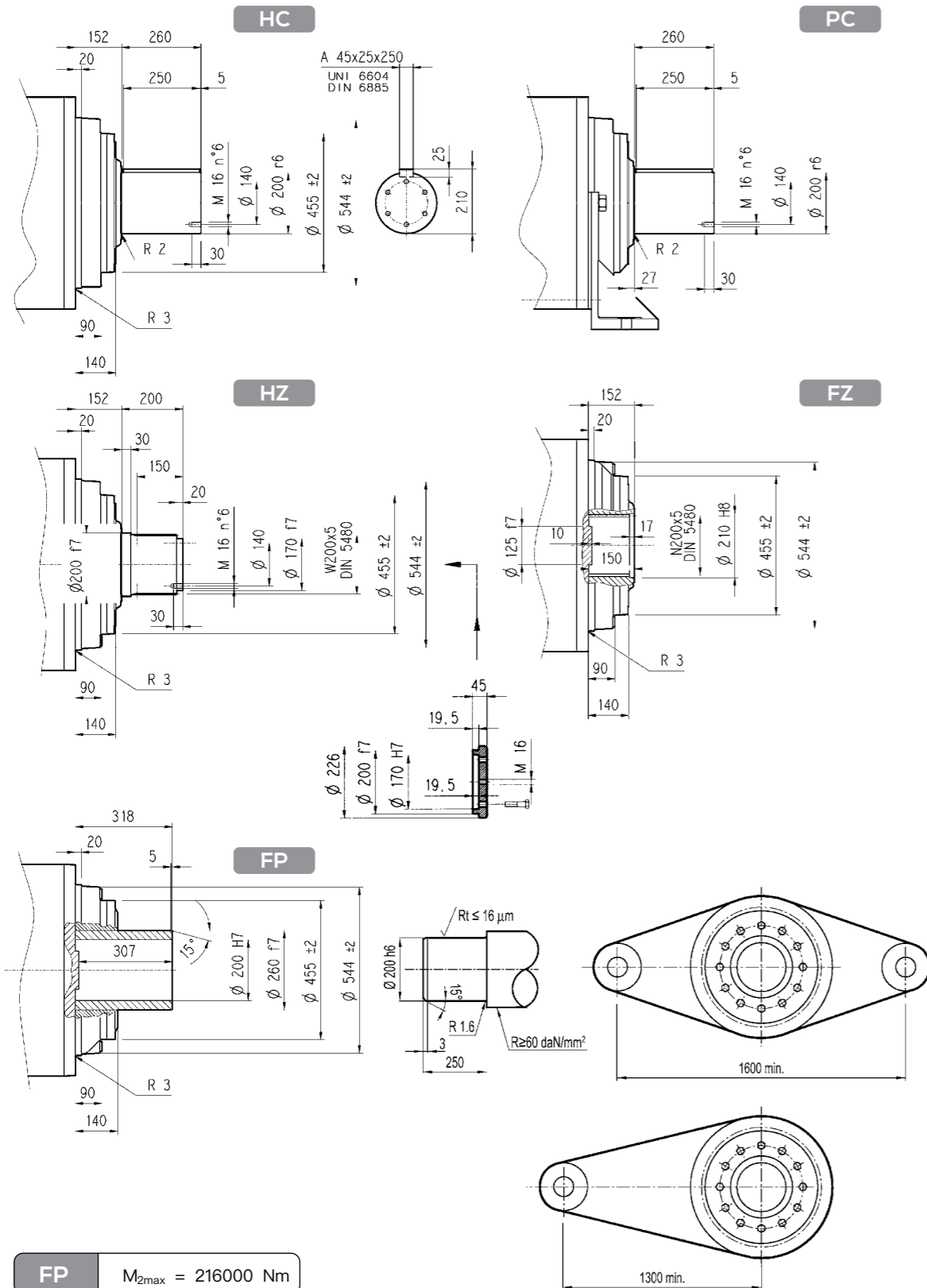

法兰 Flange

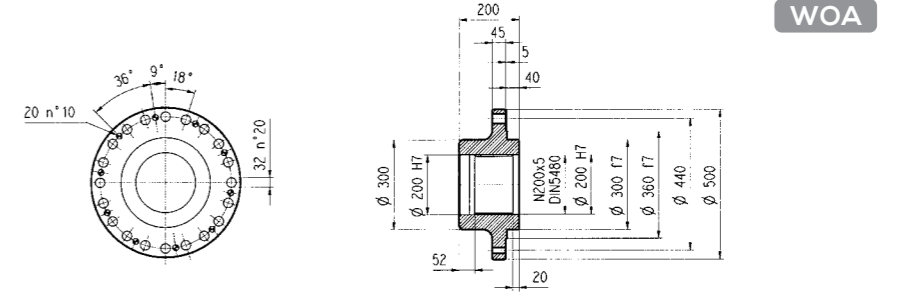
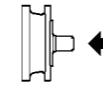

套筒联轴节 Sleeve Coupling

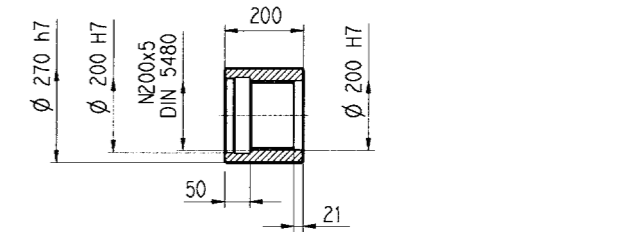

收缩盘 Shrink Disk

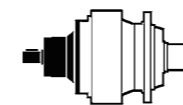
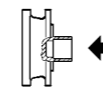

	Input	V	V1	V2	V4	V5	A	B	F	L	S	D	U
EQ317L2	V11B	343	80	130	200	445	22	14	85	110	10	M16	36
	FV11B	451	80	130	347.5	445	22	14	85	110	10	M16	36
EQ317L3	V07B	315	80	130	200	345	22	14	85	110	10	M16	36
	FV07B	375	80	130	347.5	348	22	14	85	110	10	M16	36
	VO7A	313	60	105	155	345	18	11	64	90	7.5	M16	36
EQ317L4	FV07A	363	60	105	309	348	18	11	64	90	7.5	M16	36
	V05B	239	48	82	155	245	14	9	51.5	70	6	M16	36
EQ317R3(B)(C)	FV05B	276	48	82	219.5	244	14	9	51.5	70	6	M16	36
	VO6B	307	60	105	155	292	18	11	64	90	7.5	M16	40
EQ317R4	FV06B	357	60	105	309	292	18	11	64	90	7.5	M16	36
	V05B	239	48	82	155	245	14	9	51.5	70	6	M16	36
	FV05B	276	48	82	219.5	244	14	9	51.5	70	6	M16	36

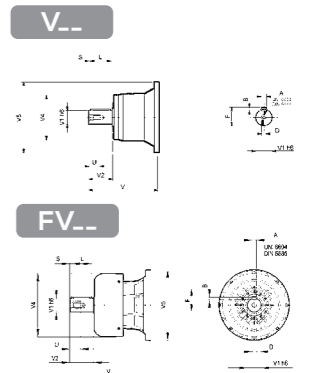

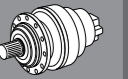
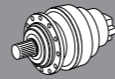

输出轴上的径向载荷位置系数  
RADIAL LOAD POSITION COEFFICIENT ON OUTPUT SHAFT

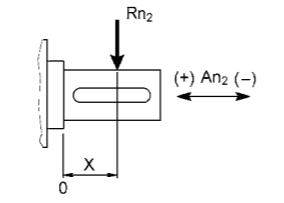
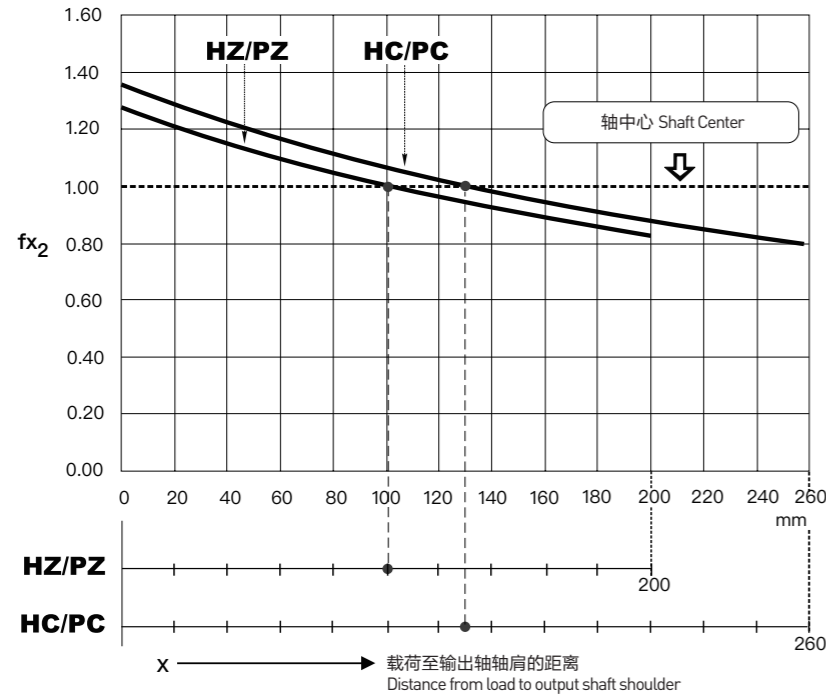

$$R_{x2} = R_{n2} \cdot f_{x2}$$

$$A_{n2} (\pm) = R_{n2} \cdot f_{a2} (\pm)$$

	$f_{a2} (+)$	$f_{a2} (-)$
HZ/PZ	0.77	0.64
HC/PC	0.81	0.68

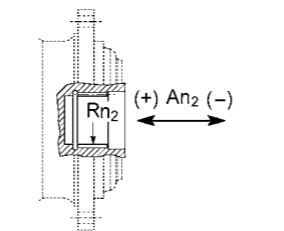

$$A_{n2} (\pm) = R_{n2} \cdot f_{a2} (\pm)$$

	$f_{a2} (+)$	$f_{a2} (-)$
FZ	1.00	1.00

输入转速 $n_1=1000\text{min}^{-1}$ 且假设使用寿命=10000小时, 输入轴上的允许悬臂荷载。  
当输入转速和/或使用寿命不同于这里所列举的值时, 参见样本: 校核。  
Input speed  $n_1=1000\text{min}^{-1}$  and assuming a service life of 10000 hours, the allowable cantilever load on the input shaft.  
When the input speed and/or service life are different from the values listed here, refer to sample: verification.

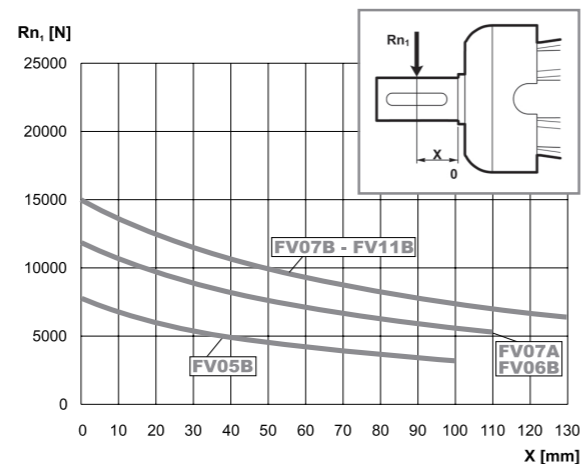
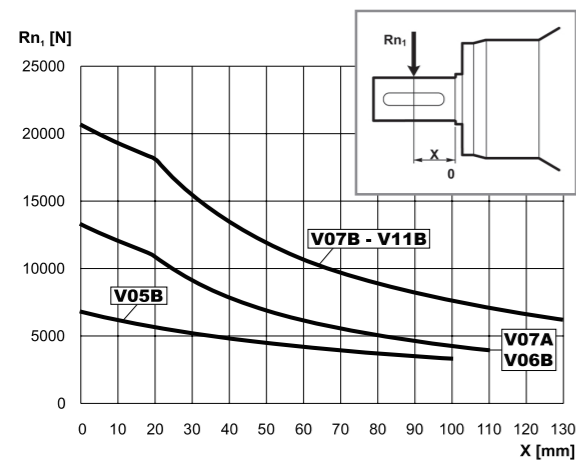

EQ318L

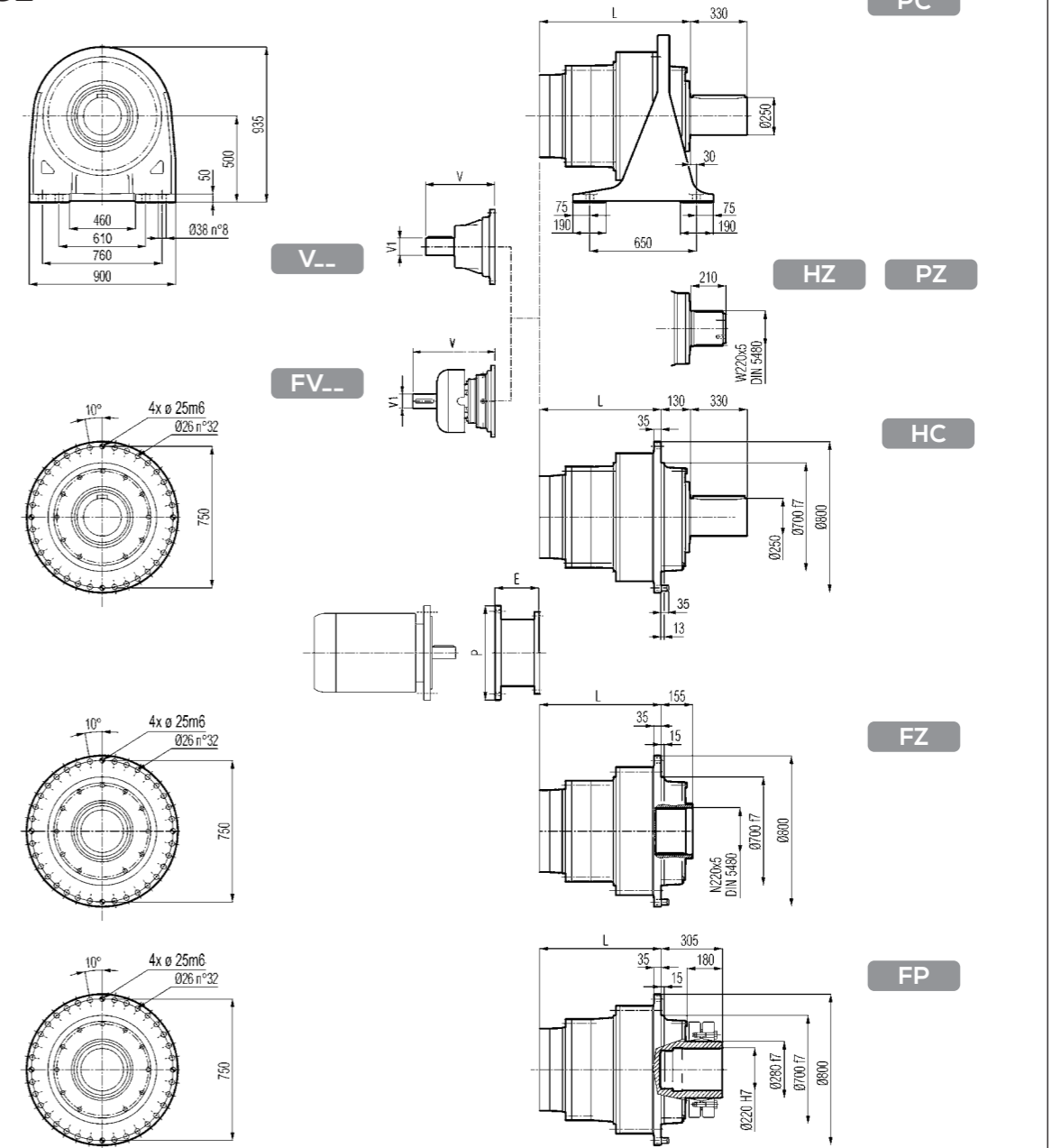

FP  $M_{2max} = 300000 \text{ Nm}$

	L				Kg				输入轴 Input Shaft				输入轴 Input Shaft				
	PC-PZ	HC-HZ	FZ	FP	PC-PZ	HC-HZ	FZ	FP	V	V1	V	V1	V	V1	V	V1	
EQ318L3	889	759	759	759	1600	1300	1150	1180	348	80	55	-	-	456	80	85	
EQ318L4	1022	892	892	892	1650	1350	1200	1230	315	80	35	313	60	28	375	80	48

EQ318L4	P180		P200		P225		P250	
	E	P	E	P	E	P	E	P
	195	350	186	400	216	450	215	550

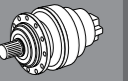
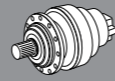

EQ318R

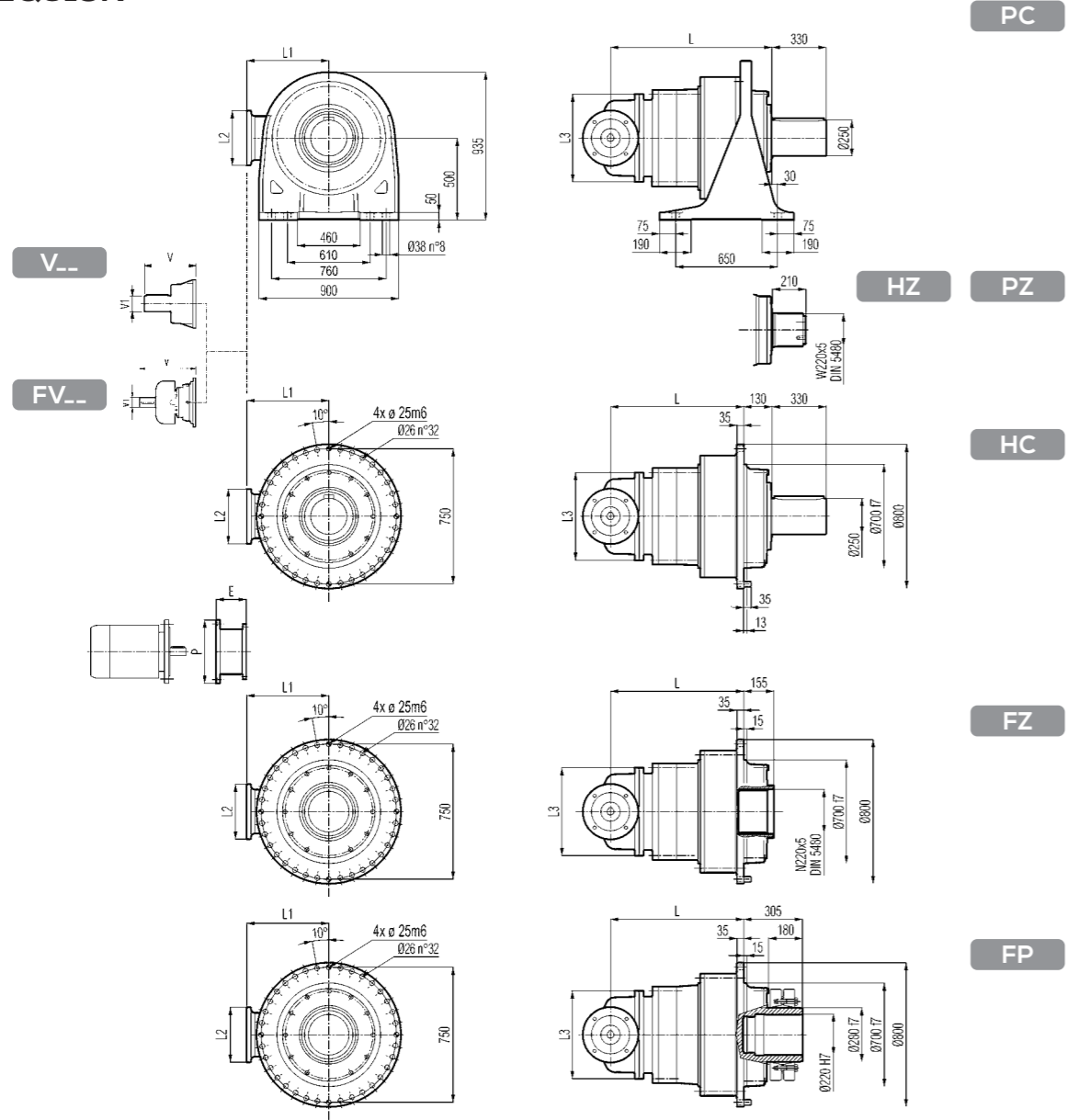

FP  $M_{2max} = 300000 \text{ Nm}$

	L				L1	L2	L3	输入轴 Input Shaft				输入轴 Input Shaft										
	PC-PZ	HC-HZ	FZ	FP				PC-PZ	HC-HZ	FZ	FP	V	V1	$K_g$	V	V1	$K_g$					
EQ318R4(B)	1115	985	985	985	345	292	400	1720	1420	1270	1300	307	60	23	-	-	-	357	60	28	-	-
EQ318R4(C)	1115	985	985	985	390	292	480	1730	1430	1280	1310	307	60	23	-	-	-	357	60	28	-	-

	P132		P160		P180		P200		P225		P250	
	E	P	E	P	E	P	E	P	E	P	E	P
EQ318R4(B)	-	-	-	-	152	350	182	400	212	450	193	550
EQ318R4(C)	-	-	-	-	152	350	182	400	212	450	193	550

EQ318L / ER318R

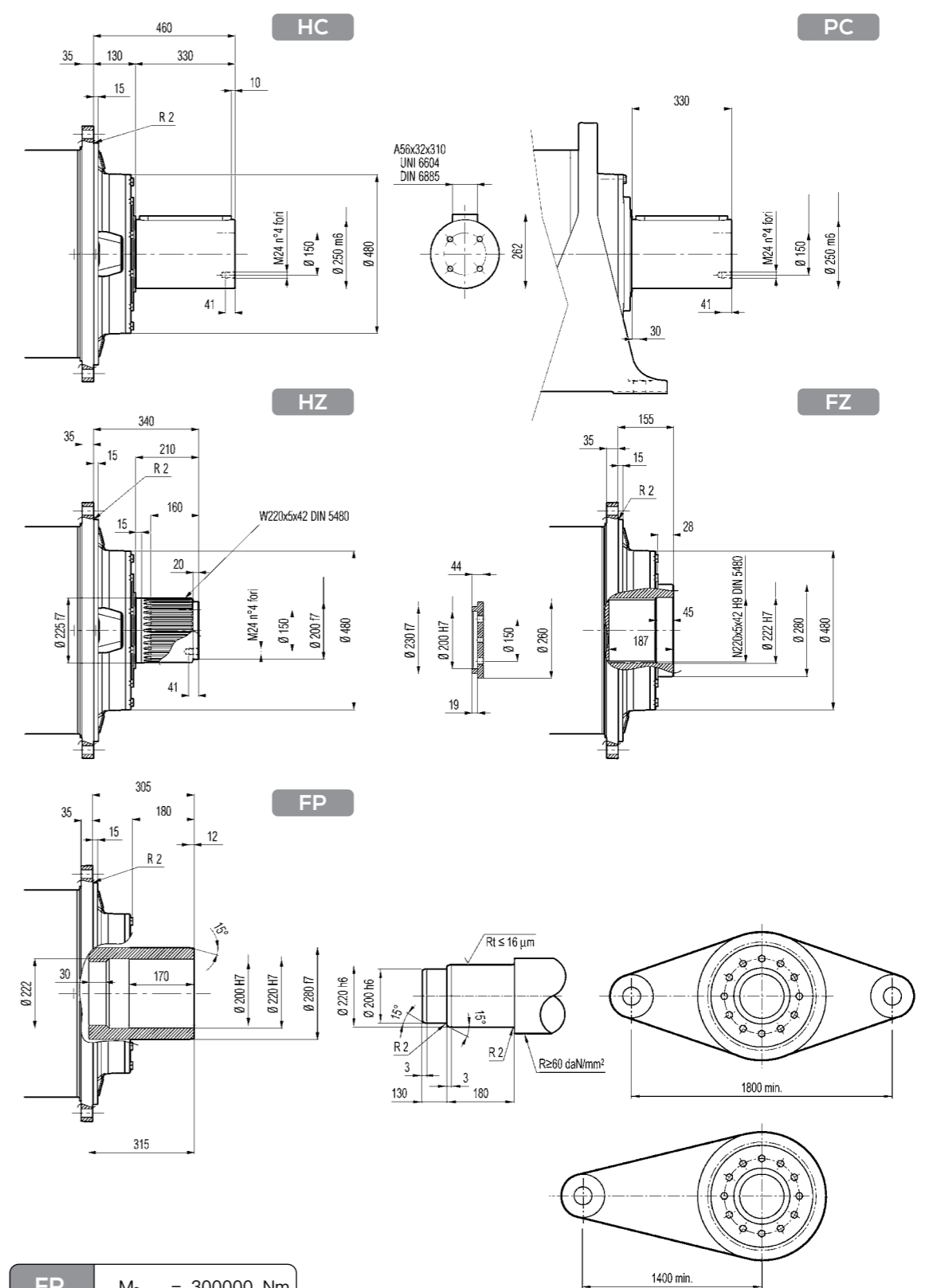

FP  $M_{2max} = 300000 \text{ Nm}$

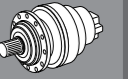
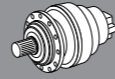

法兰 Flange

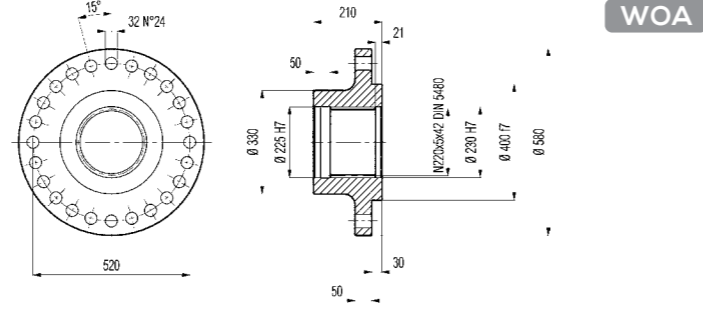
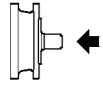

WOA

材料: 45#钢  
Material: 45 # steel

套筒联轴节 Sleeve Coupling

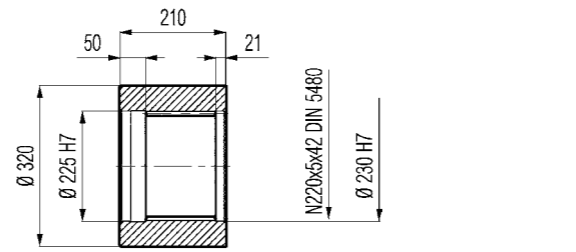

MOA

材料: 42CrMo钢  
Material: 42CrMo steel

收缩盘 Shrink Disk

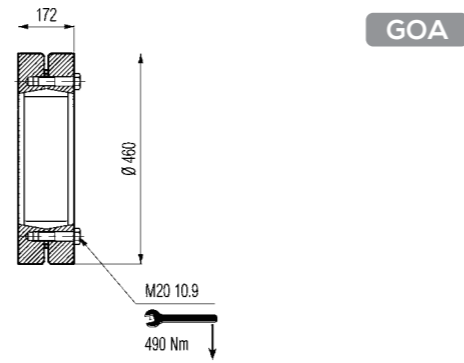
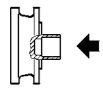

GOA

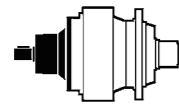

	Input	V	V1	V2	V4	V5	A	B	F	L	S	D	U
EQ318L3	V11B	348	80	130	200	428	22	14	85	110	10	M16	36
	FV11B	456	80	130	347.5	428	22	14	85	110	10	M16	36
EQ318L4	V07B	315	80	130	200	345	22	14	85	110	10	M16	36
	FV07B	375	80	130	347.5	348	22	14	85	110	10	M16	36
	V07A	313	60	105	155	345	18	11	64	90	7.5	M16	36
	FV07A	363	60	105	309	348	18	11	64	90	7.5	M16	36
EQ318R4(B)(C)	V06B	307	60	105	155	292	18	11	64	90	7.5	M16	36
	FV06B	357	60	105	309	292	18	11	64	90	7.5	M16	36

V\_..

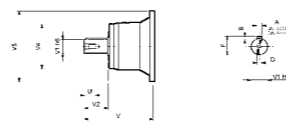

FV\_..

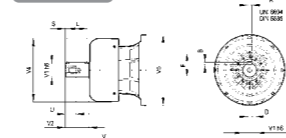

输出轴上的径向载荷位置系数

RADIAL LOAD POSITION COEFFICIENT ON OUTPUT SHAFT

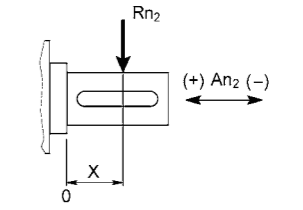
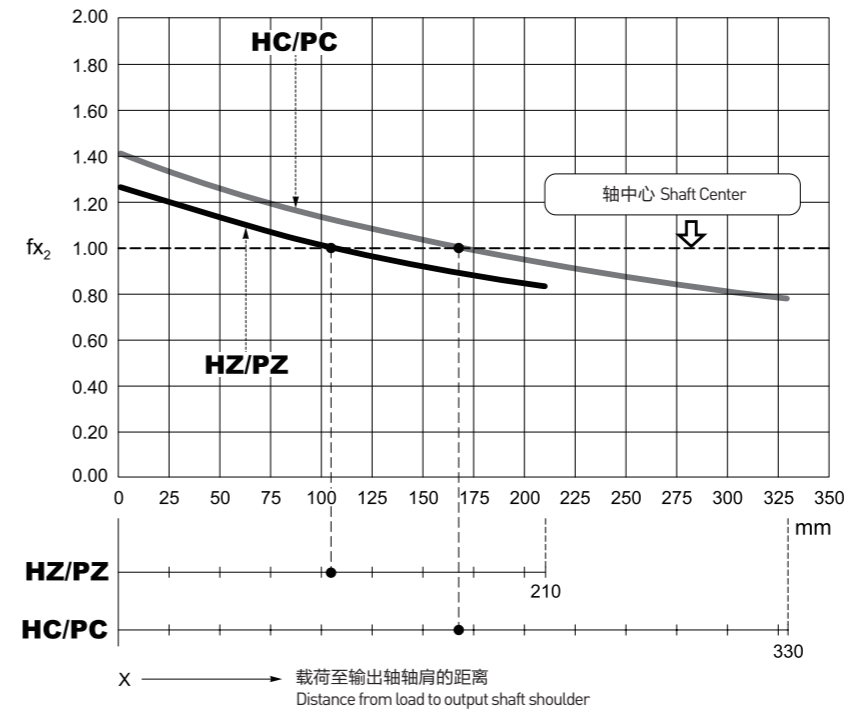

$$R_{x2} = R_{n2} \cdot f_{x2}$$

$$A_{n2} (\pm) = R_{n2} \cdot f_{a2} (\pm)$$

	$f_{a2} (+)$	$f_{a2} (-)$
HZ/PZ	0.76	0.74
HC/PC	0.68	0.66

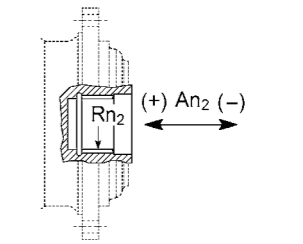

$$A_{n2} (\pm) = R_{n2} \cdot f_{a2} (\pm)$$

	$f_{a2} (+)$	$f_{a2} (-)$
FZ	0.90	0.90

输入转速 $n_1=1000\text{min}^{-1}$ 且假设使用寿命=10000小时, 输入轴上的允许悬臂荷载。

当输入转速和/或使用寿命不同于这里所列举的值时, 参见样本: 校核。

Input speed  $n_1=1000\text{min}^{-1}$  and assuming a service life of 10000 hours, the allowable cantilever load on the input shaft.

When the input speed and/or service life are different from the values listed here, refer to sample: verification.

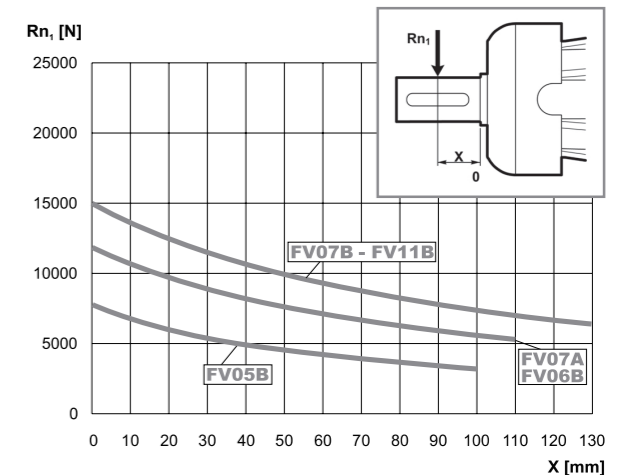
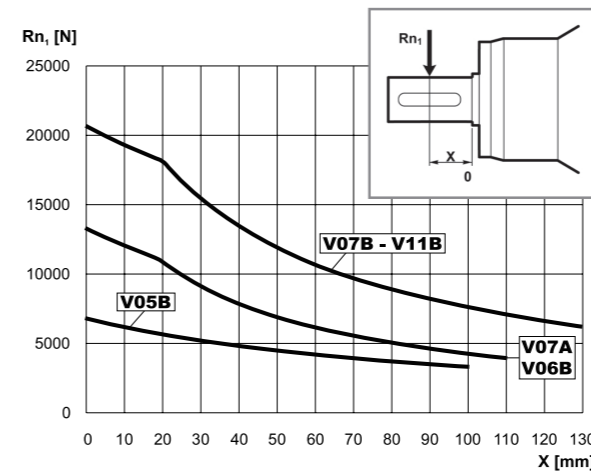



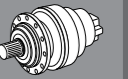
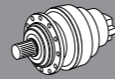

EQ319L / ER319R

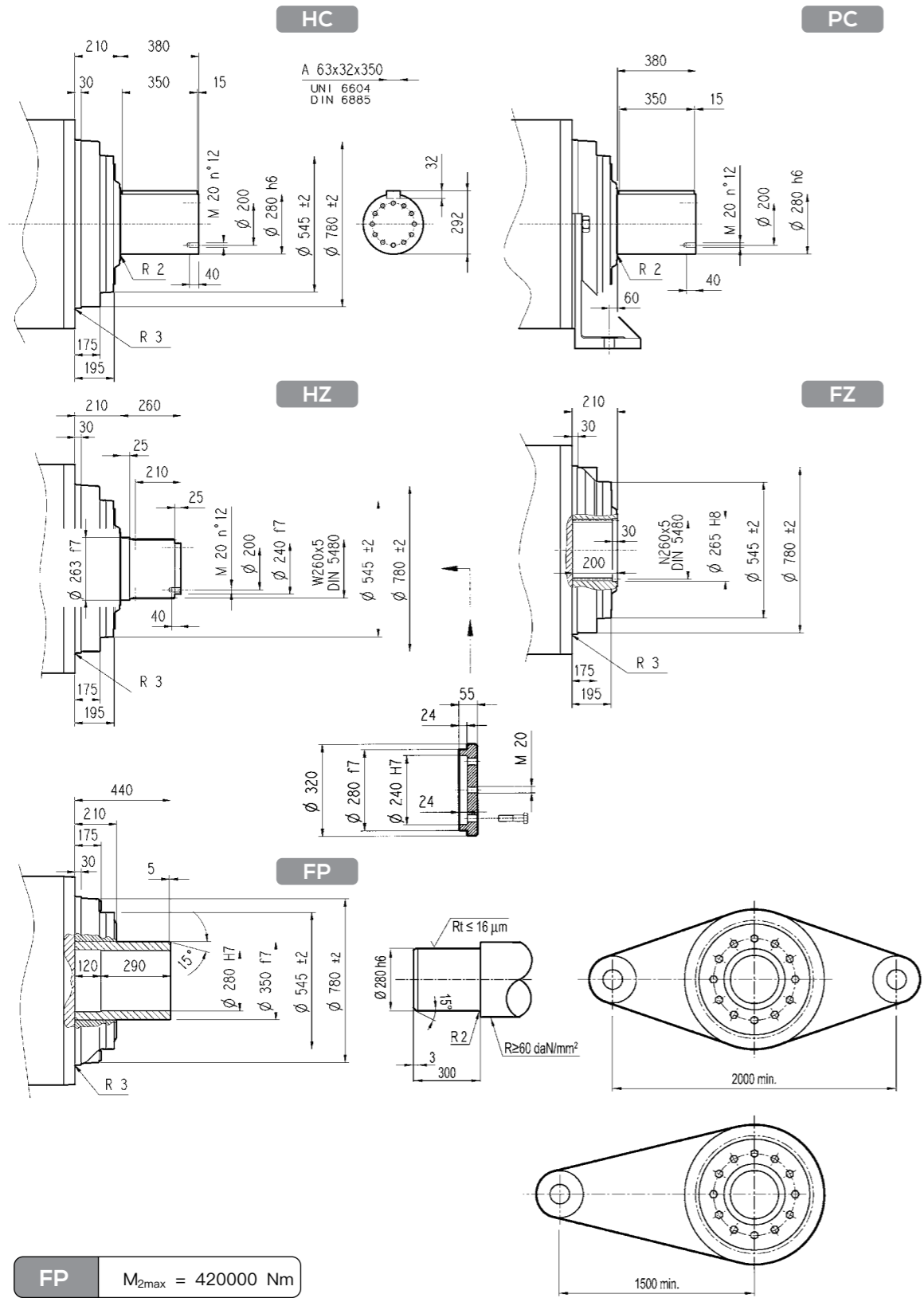

法兰 Flange

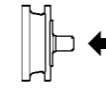

材料: 45#钢  
Material: 45 # steel

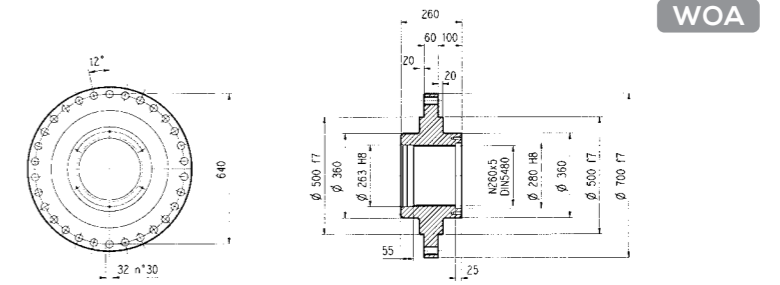

套筒联轴节 Sleeve Coupling



材料: 42CrMo钢  
Material: 42CrMo steel

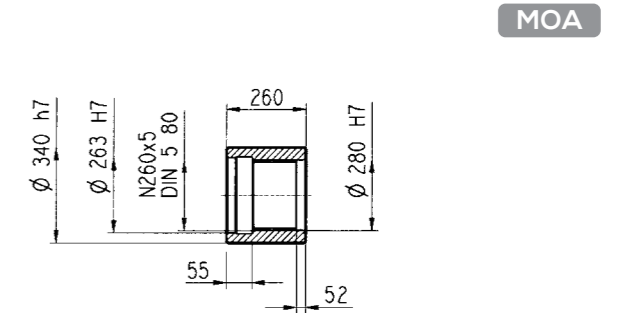

收缩盘 Shrink Disk

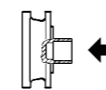

材料: 42CrMo钢  
Material: 42CrMo steel

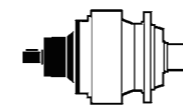
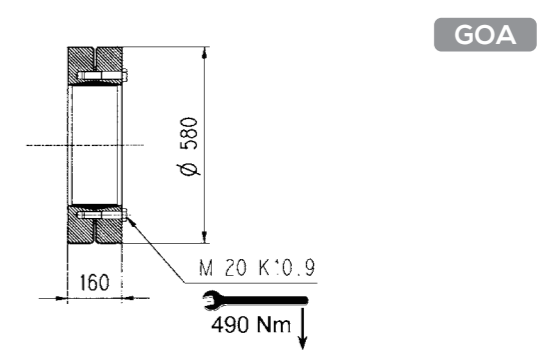

	Input	V	V1	V2	V4	V5	A	B	F	L	S	D	U
EQ319L3	V11B	348	80	130	200	428	22	14	85	110	10	M16	36
	FV11B	456	80	130	347.5	428	22	14	85	110	10	M16	36
EQ319L4	V07B	315	80	130	200	345	22	14	85	110	10	M16	36
	FV07B	375	80	130	347.5	348	22	14	85	110	10	M16	36
	VO7A	313	60	105	155	345	18	11	64	90	7.5	M16	36
	FV07A	363	60	105	309	348	18	11	64	90	7.5	M16	36
EQ319R4(B)(C)	V06B	307	60	105	155	292	18	11	64	90	7.5	M16	36
	FV06B	357	60	105	309	292	18	11	64	90	7.5	M16	36

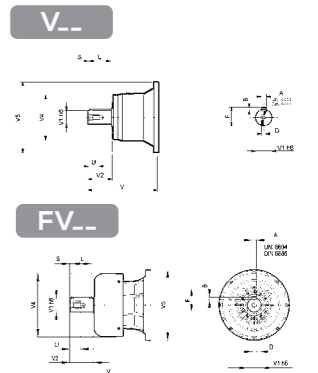

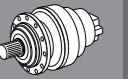
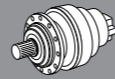

输出轴上的径向载荷位置系数  
RADIAL LOAD POSITION COEFFICIENT ON OUTPUT SHAFT

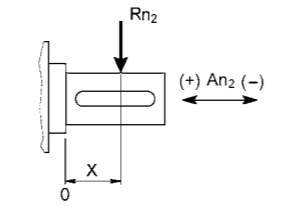
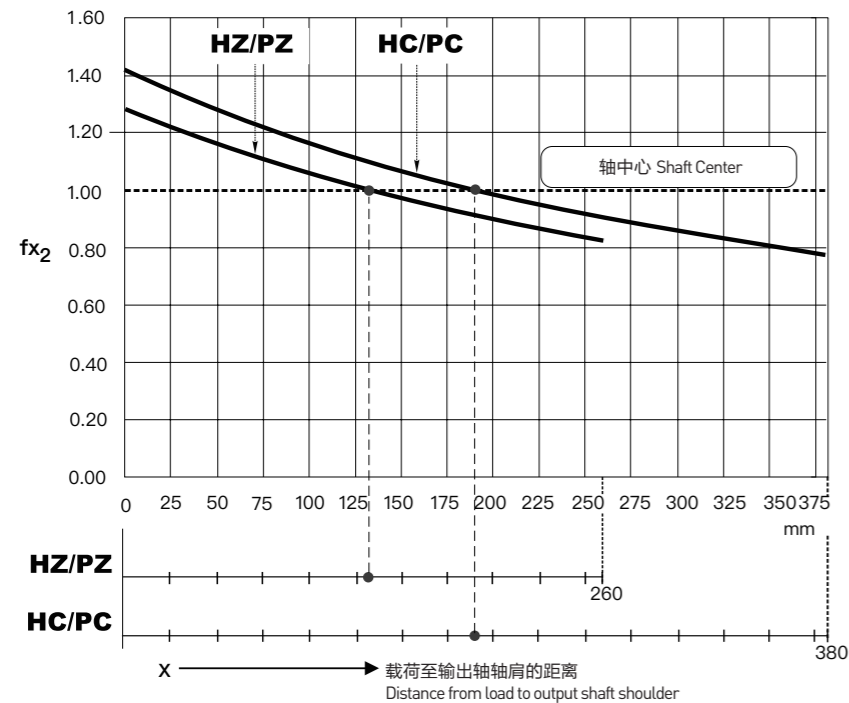

$R_{x2} = R_{n2} \cdot f_{x2}$		
$An_2 (\pm) = R_{n2} \cdot fa_2 (\pm)$		
	$fa_2 (+)$	$fa_2 (-)$
HZ/PZ	0.71	0.64
HC/PC	0.78	0.71

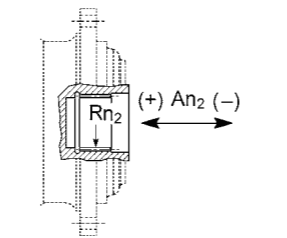

$An_2 (\pm) = R_{n2} \cdot fa_2 (\pm)$		
	$fa_2 (+)$	$fa_2 (-)$
FZ	1.00	1.00

输入转速 $n_1=1000\text{min}^{-1}$ 且假设使用寿命=10000小时, 输入轴上的允许悬臂荷载。  
当输入转速和/或使用寿命不同于这里所列举的值时, 参见样本: 校核。  
Input speed  $n_1=1000\text{min}^{-1}$  and assuming a service life of 10000 hours, the allowable cantilever load on the input shaft.  
When the input speed and/or service life are different from the values listed here, refer to sample: verification.

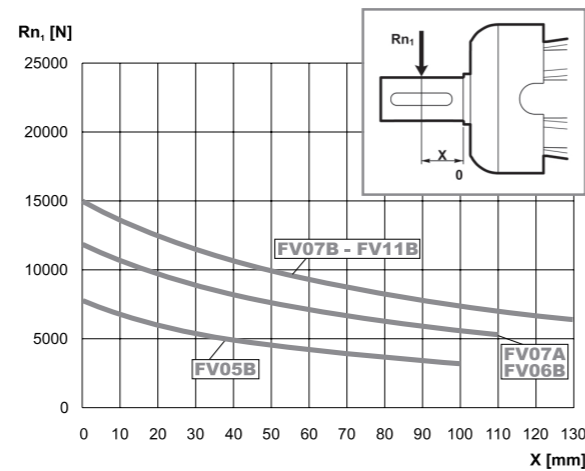
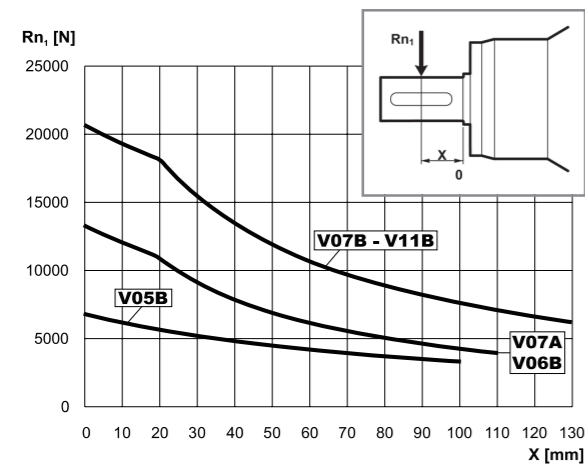

EQ321L

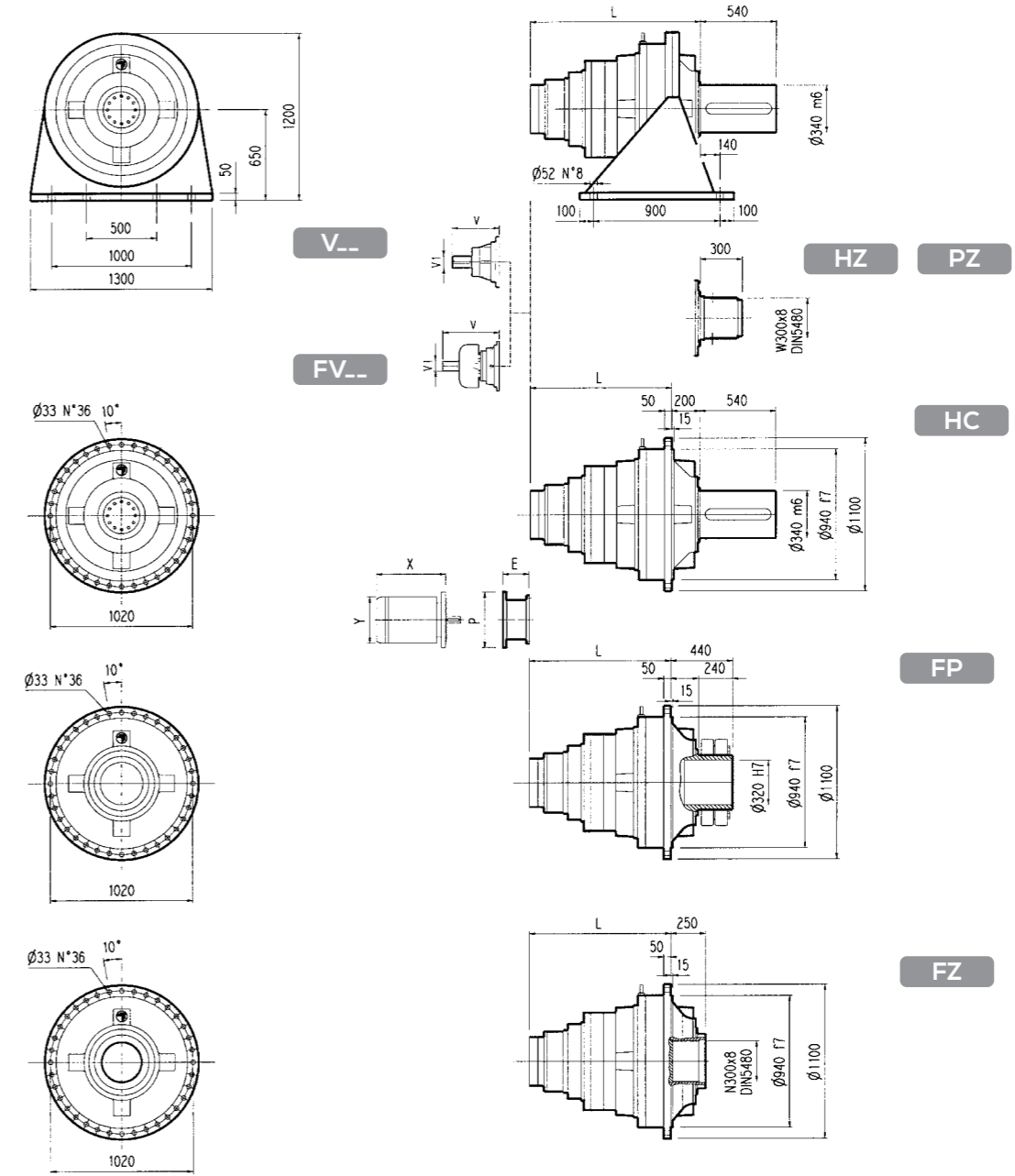

FP  $M_{2max} = 648000 \text{ Nm}$

	L				Kg				输入轴 Input Shaft				输入轴 Input Shaft					
	PC-PZ	HC-HZ	FZ	FP	PC-PZ	HC-HZ	FZ	FP	V	V1	Kg	V	V1	Kg	V	V1	Kg	
EQ321L3	1104	904	904	904	3120	2820	2720	2720	343	80	55	-	-	-	451	80	71	-
EQ321L4	1253	1053	1053	1053	3180	2880	2780	2780	315	80	35	313	60	28	375	80	48	363

	P180		P200		P225		P250	
	E	P	E	P	E	P	E	P
EQ321L4	195	350	186	400	216	450	216	550

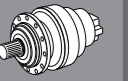
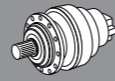

EQ321R

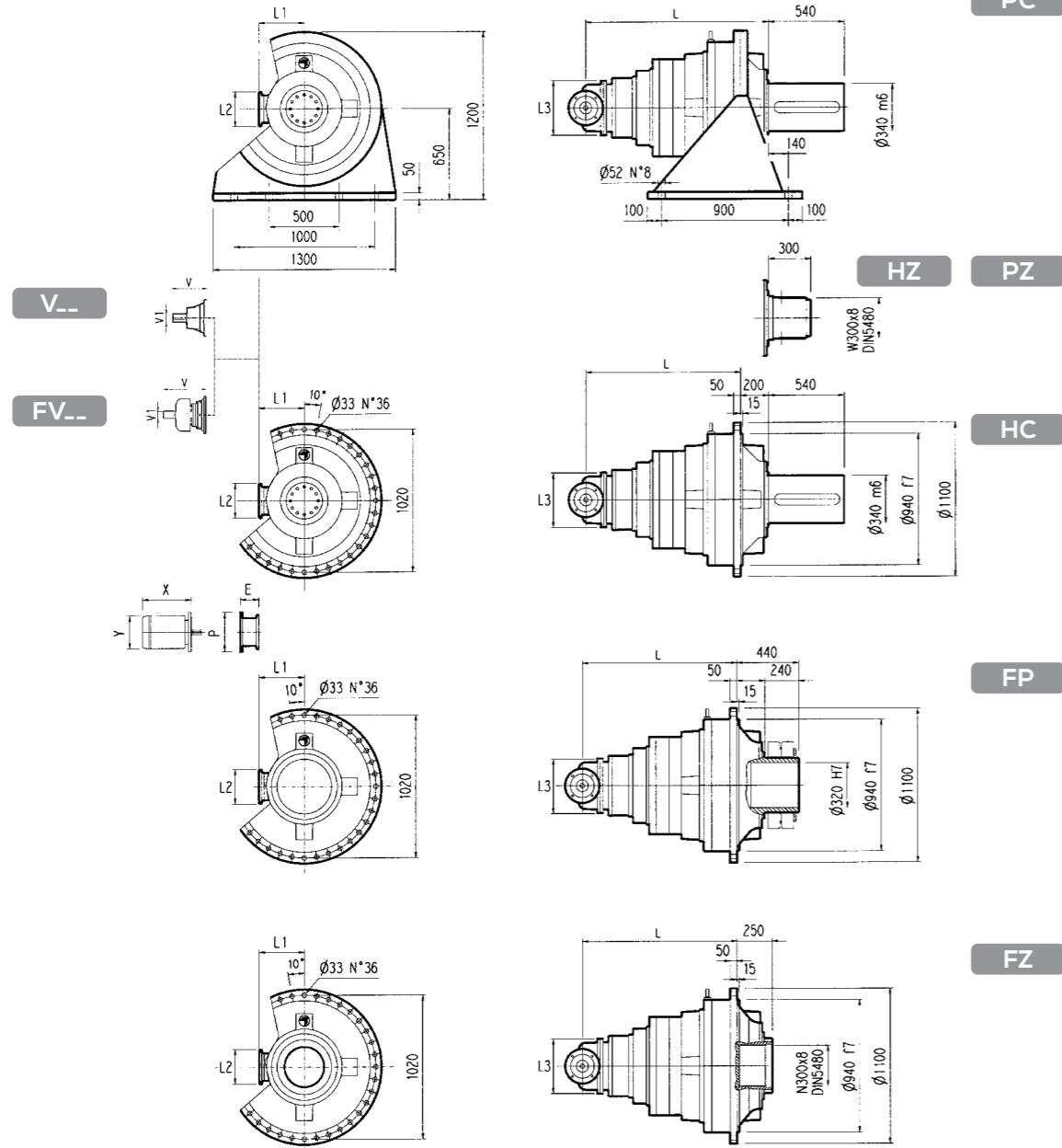

FP  $M_{2max} = 648000 \text{ Nm}$

	L				L1	L2	L3	输入轴 Input Shaft				输入轴 Input Shaft										
	PC-PZ	HC-HZ	FZ	FP				PC-PZ	HC-HZ	FZ	FP	V	V1	kg	V	V1	kg					
EQ321R4(B)	1334	1334	1334	1334	345	292	400	3250	2950	2850	2850	307	60	23	-	-	-	357	60	28	-	-
EQ321R4(C)	1334	1334	1334	1334	390	292	480	3260	2960	2860	2860	307	60	23	-	-	-	357	60	28	-	-

	P132		P160		P180		P200		P225		P250	
	E	P	E	P	E	P	E	P	E	P	E	P
EQ321R4(B)	-	-	-	-	152	350	182	400	212	450	193	550
EQ321R4(C)	-	-	-	-	152	350	182	400	212	450	193	550

EQ321L / ER321R

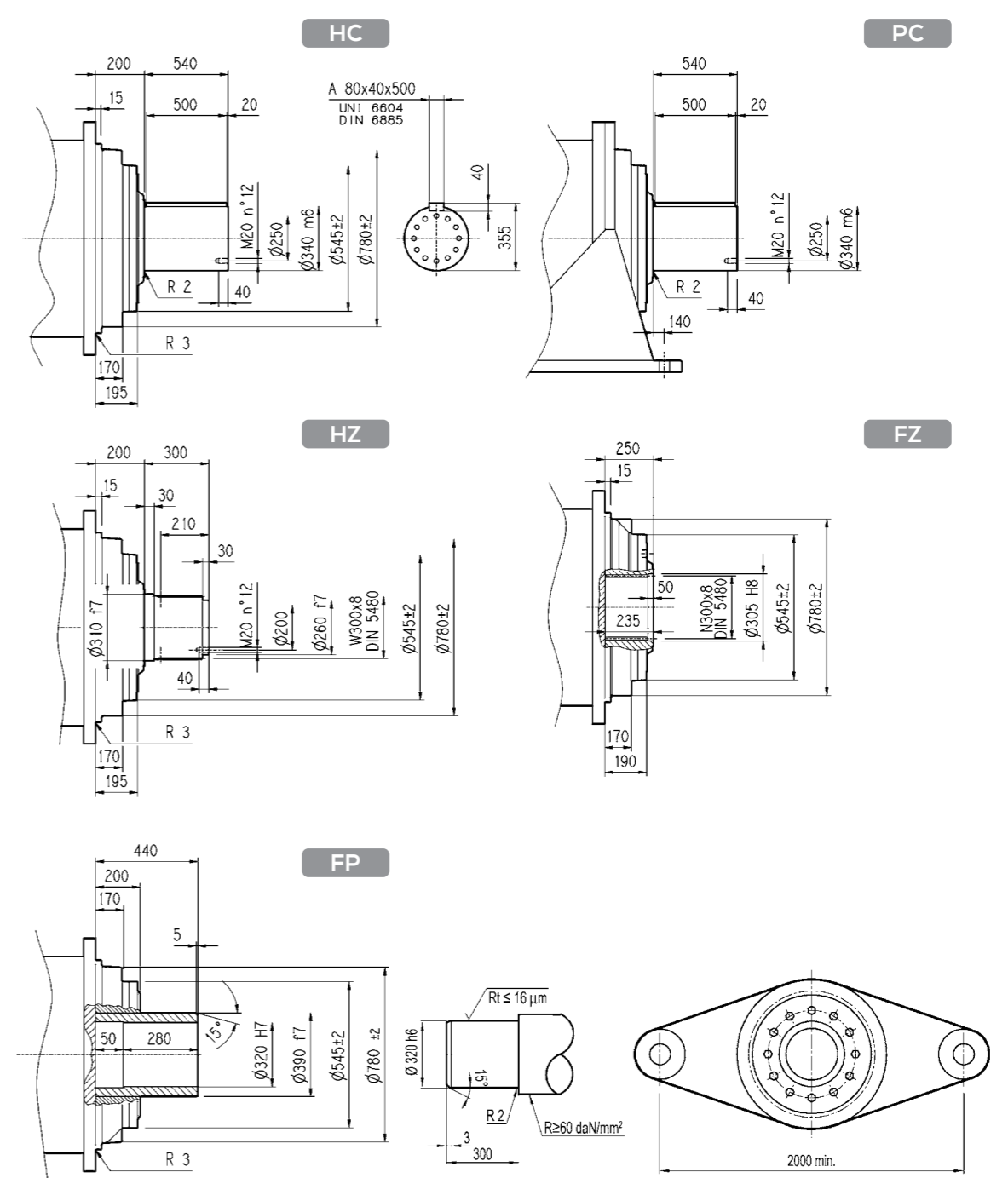

FP  $M_{2max} = 648000 \text{ Nm}$

